

IMPORTANT: KEEP THIS DOCUMENT WITH THE PRODUCT UNTIL IT REACHES THE END USER.

⚠ WARNING

The A120MAN Fail Safe Remote Manual Release must be used for **ANHYDROUS AMMONIA APPLICATIONS ONLY**.
DO NOT USE IN LPG/PROPANE SERVICE.

USER SAFETY RESPONSIBILITY STATEMENT FOR SQUIBB TAYLOR PRODUCTS

FAILURE OR IMPROPER SELECTION OR IMPROPER USE OF THE PRODUCTS DESCRIBED HEREIN OR RELATED ITEMS CAN CAUSE DEATH, PERSONAL INJURY AND PROPERTY DAMAGE.

- This document and other information from Squibb Taylor and authorized distributors provide product or system options for further investigation by users having technical expertise.
- The user, through its own analysis and testing, is solely responsible for making the final selection of the system and components and assuring that all performance, endurance, maintenance, safety and warning requirements of the application are met. The user must analyze all aspects of the application, follow applicable industry standards, and follow the information concerning the product in the current product catalog and in any other materials provided from Squibb Taylor or authorized distributors.

To the extent that Squibb Taylor or authorized distributors provide component or system options based upon data or specifications provided by the user, the user is responsible for determining that such data and specifications are suitable and sufficient for all applications and reasonably foreseeable uses of the components or systems.

Failure to follow these instructions or to properly install and maintain this equipment could result in personal injury or death. Equipment must be installed, operated and maintained in accordance with federal, state and local codes. The installation must also comply with NFPA No. 70 and ANSI K61.1, (CGA G-2.1) standards and/or local authority having jurisdiction. Only personnel trained in the proper procedures, codes, standards and regulations of the Anhydrous Ammonia industry shall install and service this equipment.

Scope of the Manual

This instruction manual covers installation, operation, & maintenance for the A120MAN Manual Release for 1 1/4" (A120) & 1 1/2" (A125 & A15) internal valves manufactured by Marshall Excelsior Co. for outdoor Anhydrous Ammonia (NH3) applications.

**PATENT
PENDING**

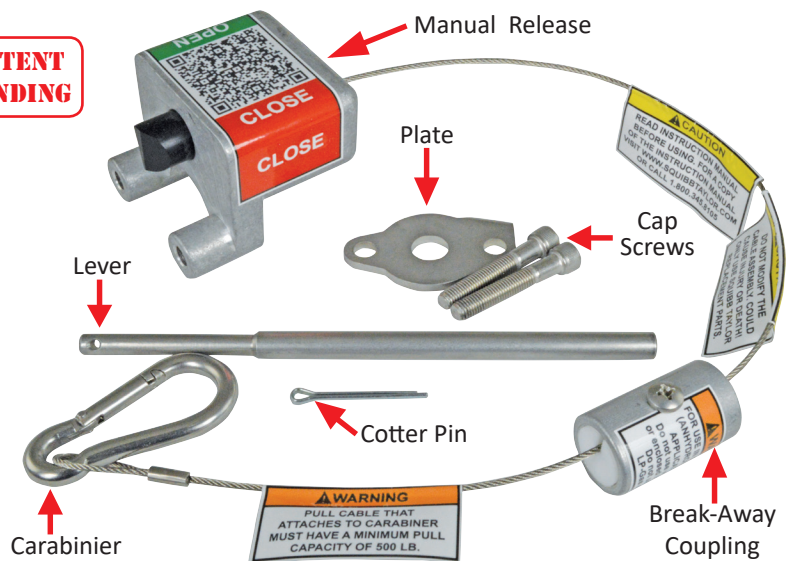

Parts List

Part Description	Qty.
Manual Release with Break-Away Coupling	1 Pc.
Lever	1 Pc.
Plate	1 Pc.
Cotter Pin	1 Pc.
Hex Mounting Cap Screws	2 Pc.
Carabinier	1 Pc.

NOTE: REFER TO THE INSTRUCTION MANUAL SUPPLIED WITH THE INTERNAL VALVE OR SQUIBB TAYLOR'S WEBSITE FOR ALL WARNINGS, CUSTOMER NOTIFICATIONS, SPECIFICATIONS, OPERATION, CAUTIONS, MAINTENANCE, & PARTS. CALL SQUIBB TAYLOR @ 800.345.8105 WITH ANY QUESTIONS BEFORE PROCEEDING.

While this information is presented in good faith and believed to be accurate, Individuals using this literature must exercise their independent judgment in evaluating product selection and determining product appropriateness for their particular purpose, system requirements and certifications. The manufacturer reserves the right to change product designs and specifications without notice.

Installation On The A120-45A & A120-60A Valves

⚠ WARNING

When installing or removing Internal Valve from tank, make sure all Product & Pressure has been removed from Nurse Tank and any Downstream Piping.

1. Remove Plate & Cap Screws from Gland Assembly. These can be discarded.

Cap Screws & Plate

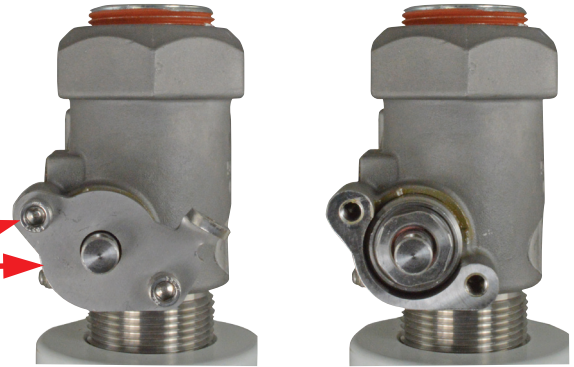

Tool Used: 5/16" Allen Wrench

2. Install the Plate as shown. Insert the thin end of the Lever into the shaft of the Gland Assembly. Line up the hole in Lever with the hole in the Gland Assembly Shaft & insert the Cotter Pin.

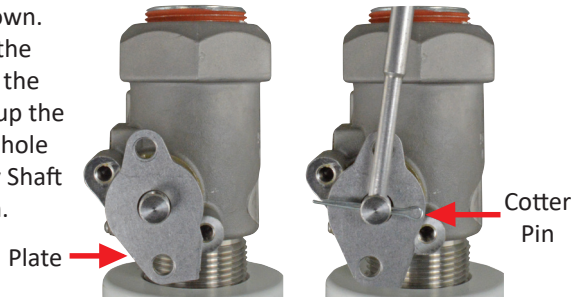

3. Secure the Lever to the Gland Assembly Shaft by bending the ends of the Cotter Pin back to secure it. Verify that the Cotter Pin ends DO NOT rub against the Plate.

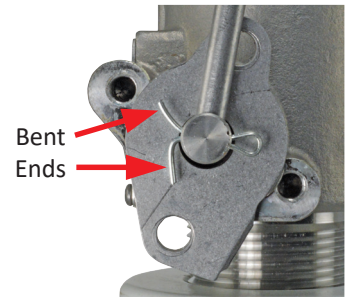

4. Attach the Manual Release onto the valve. Insert the New Cap Screws(2) into the Manual Release. Line up the holes on the plate with the holes on the valve. Line up the Manual Release with the holes on the plate & valve. Start threading the screws into the valve.

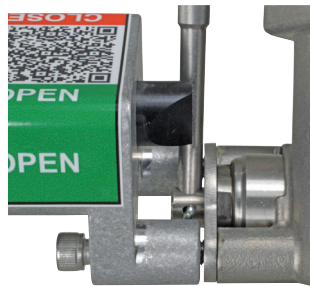

5. Secure the Manual Release onto the valve by tightening the Cap Screws(2) with an Allen Wrench to 25 - 30 Inch-Pounds of Torque.

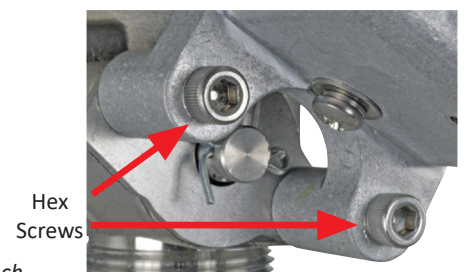

Tool Used: 5/16" Allen Wrench

6. Test the Open operation of the Manual Release. Move the Lever to the right until it stops & release it. The plunger on the Manual Release should have retracted into the Release Housing to allow movement of the lever. Once the Lever moves past the plunger it should pop out to prevent it from moving back to the Closed Position.

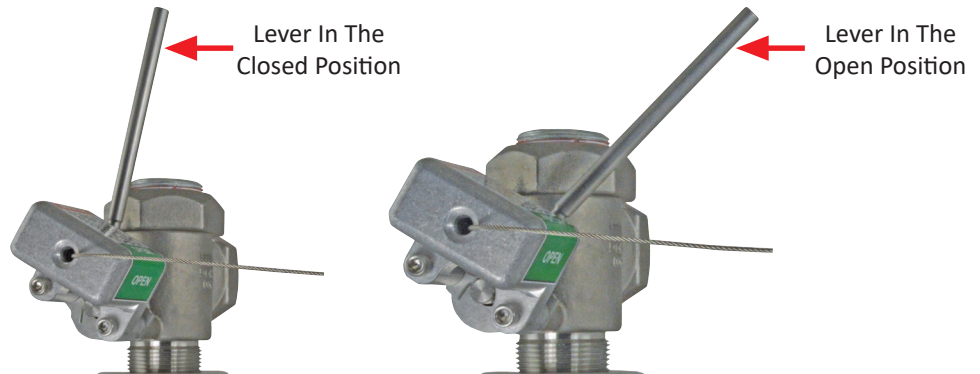

7. Test the Close operation of the Manual Release. Pull on the Carabinier on the end of the cable until the plunger retracts & allowing the Lever to move to the Closed Position. Release the cable. Check the position of the lever to make sure that valve is closed. Check the plunger to make sure that it has popped back out.

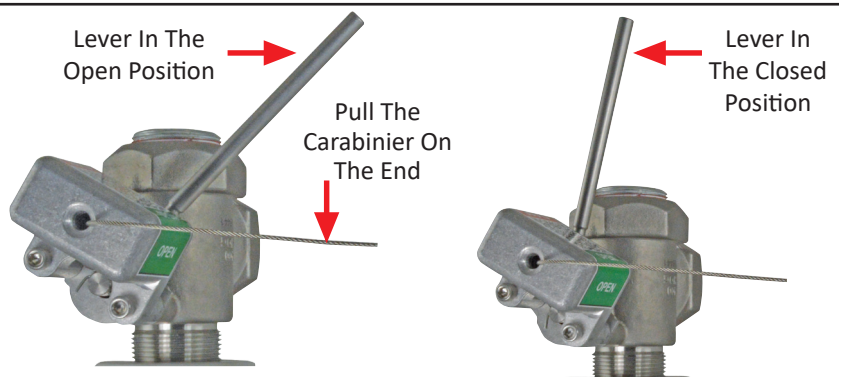

⚠ WARNING

Since there is strong spring force on the operating lever, avoid getting in the way of the lever as it moves to the closed position. Failure to do so could result in personal injury.

While this information is presented in good faith and believed to be accurate, Individuals using this literature must exercise their independent judgment in evaluating product selection and determining product appropriateness for their particular purpose, system requirements and certifications. The manufacturer reserves the right to change product designs and specifications without notice.

Operation Of The A120-45A & A120-60A Valves

To Open Valve

1. Always open the internal valve before opening any other valves in the line.
2. Move the lever to the half-open (rapid equalization) position (Operational Schematic Figure 1, View #2 - A120, A125, A15 IOM) to equalize pressure. When the main poppet clicks open, move the operating lever fully open.
3. Open other line valves slowly to avoid sudden surges which could slug the excess flow valve shut.
4. If the excess flow valve does close, close the nearest downstream valve. Move the internal valve's operating lever back to the rapid equalizing position (outlined in step 2) and wait for the valve to click open. Then move the operating lever fully open and slowly open the downstream valve.

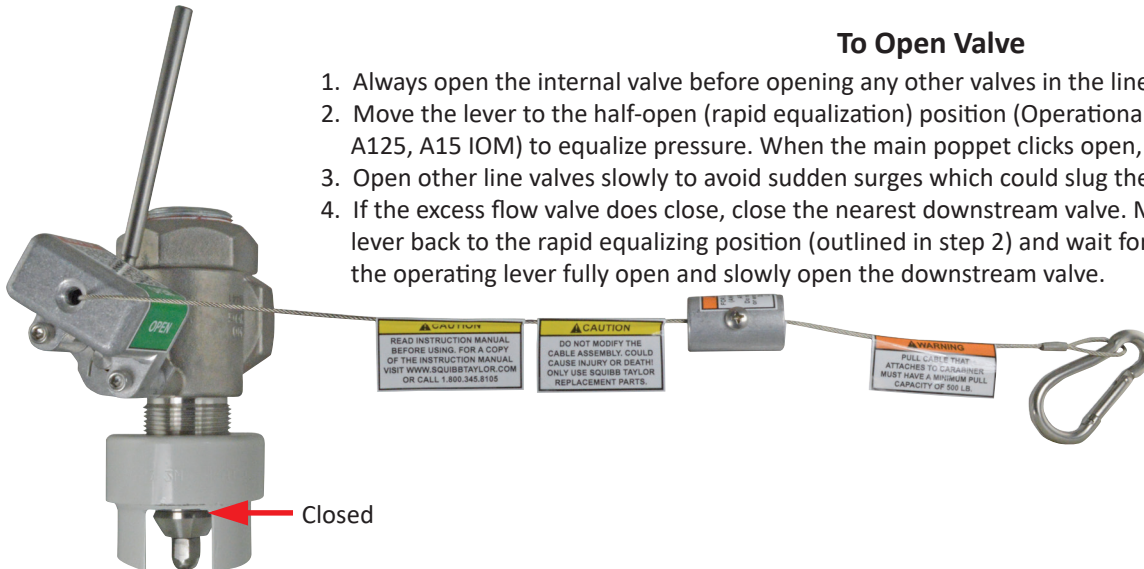

CAUTION

DO NOT Force open lever against NH3 Nurse Tank flow before pressure is equalized on each side of the main valve disk.
DO NOT Modify the Cable/Carabiner Assembly. Could cause Injury or Death! Only Use Squibb Taylor Replacement Parts.

To Close Valve

Pull on the Loop End of the Cable. The plunger will retract to allow the lever to move. The closing spring causes the valve to close.

The operator must always be aware of where the remote closure controls are located and know how to operate the controls if an emergency requires valve closure. When finished, make a habit of closing the internal valve from the remote closure point, thus checking to see that the control actually is capable of closing the valve and operating correctly.

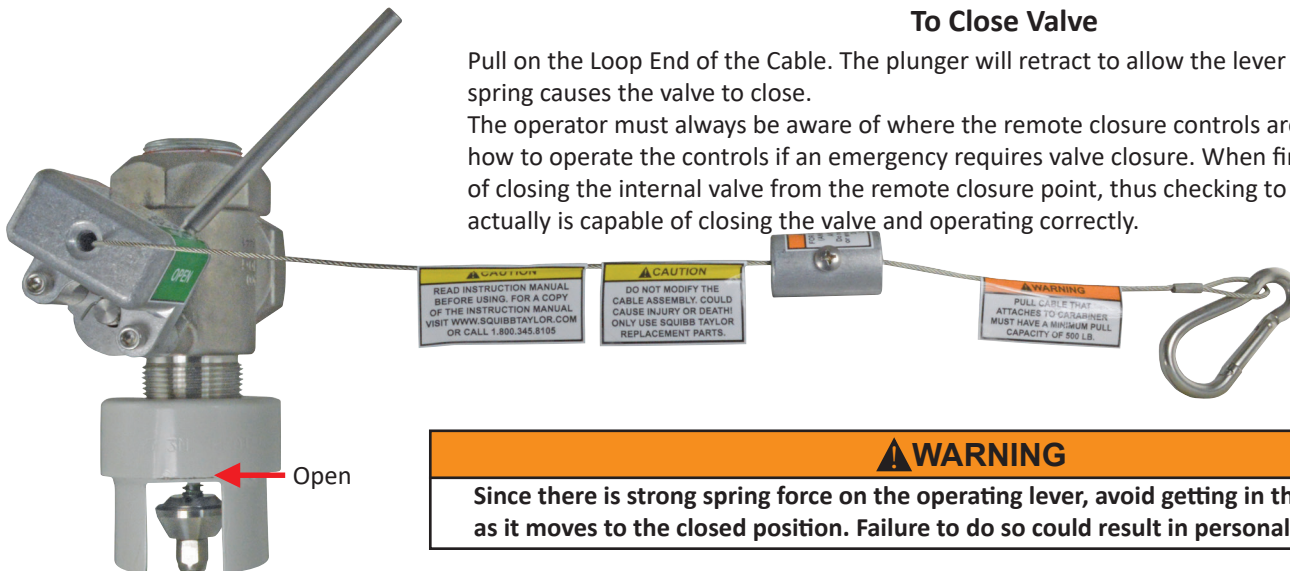

WARNING

Since there is strong spring force on the operating lever, avoid getting in the way of the lever as it moves to the closed position. Failure to do so could result in personal injury.

Assembled Valve & Manual Release is now an Emergency Shutoff Valve for Anhydrous Ammonia (NH3) Nurse Tank.

- Test For Proper Operation @ A Minimum Of Once A Month & Daily During Field Application Periods.
- Always Test Operation Before Sending To Field For Use.

Maintenance

WARNING

ONLY PERSONNEL TRAINED IN THE PROPER PROCEDURES, CODES, STANDARDS & REGULATIONS OF THE ANHYDROUS AMMONIA INDUSTRY SHALL PERFORM MAINTENANCE ON THIS EQUIPMENT. Before starting any type of maintenance, close off the A120MAN valve(s) & remove all Anhydrous Ammonia (NH3) pressure from the Outlet of the Internal Shutoff Valve. If maintenance or repairs are to be made on the internal valve(s), refer to the Instruction Manual for the particular valve model. An A120MAN manual release that has been disassembled must be tested for proper operation before being returned to service.

CHECK ACTUATOR PERIODICALLY FOR THE FOLLOWING:

1. See that the manual release is properly connected, works freely and is not worn.
2. Make sure there are no obstructions or debris to block the valve and lever from closing.
3. Make sure that both cables move freely inside the Break-Away Coupling.

While this information is presented in good faith and believed to be accurate, Individuals using this literature must exercise their independent judgment in evaluating product selection and determining product appropriateness for their particular purpose, system requirements and certifications. The manufacturer reserves the right to change product designs and specifications without notice.

Installation On The A125-45A, A125-60A, A15-45A, & A15-60A Valves

⚠ WARNING

When installing or removing Internal Valve from tank, make sure all Product & Pressure has been removed from Nurse Tank and any Downstream Piping.

1. Remove Plate & Cap Screws from Gland Assembly. These can be discarded.

Cap Screws & Plate

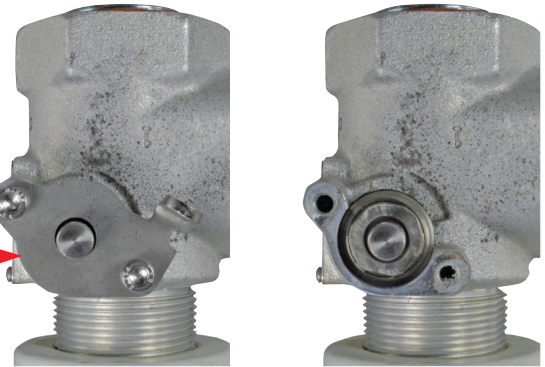

Tool Used: 5/16" Allen Wrench

2. Install the Plate as shown. Insert the thin end of the Lever into the shaft of the Gland Assembly. Line up the hole in Lever with the hole in the Gland Assembly Shaft & insert the Cotter Pin.

Plate

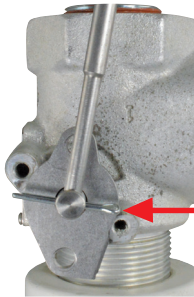

Cotter Pin

3. Secure the Lever to the Gland Assembly Shaft by bending the ends of the Cotter Pin back to secure it. Verify that the Cotter Pin ends DO NOT rub against the Plate.

Bent Ends

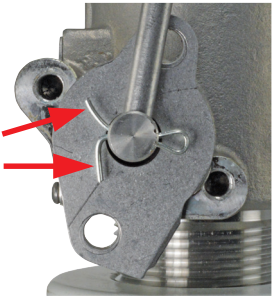

4. Attach the Manual Release onto the valve. Insert the New Cap Screws(2) into the Manual Release. Line up the holes on the plate with the holes on the valve. Line up the Manual Release with the holes on the plate & valve. Start threading the screws into the valve.

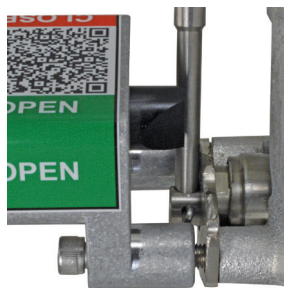

5. Secure the Manual Release onto the valve by tightening the Cap Screws(2) with an Allen Wrench to 25 - 30 Inch-Pounds of Torque.

Tool Used: 5/16" Allen Wrench

Hex Screws

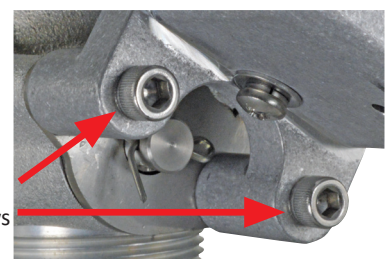

6. Test the Open operation of the Manual Release. Move the Lever to the right until it stops & release it. The plunger on the Manual Release should have retracted into the Release Housing to allow movement of the lever. Once the Lever moves past the plunger it should pop out to prevent it from moving back to the Closed Position.

Lever In The Closed Position

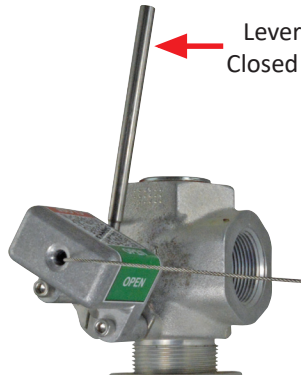

Lever In The Open Position

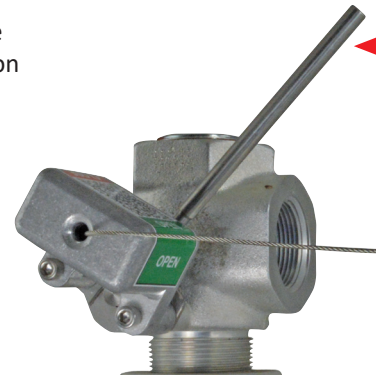

7. Test the Close operation of the Manual Release. Pull on the Carabinier on the end of the cable until the plunger retracts & allowing the Lever to move to the Closed Position. Release the cable. Check the position of the lever to make sure that valve is closed. Check the plunger to make sure that it has popped back out.

Lever In The Open Position

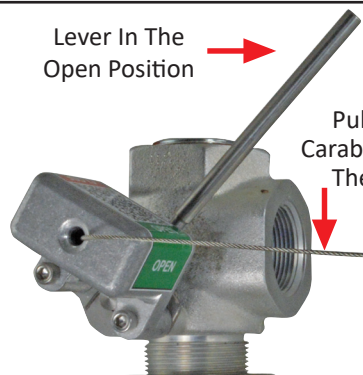

Pull The Carabinier On The End

Lever In The Closed Position

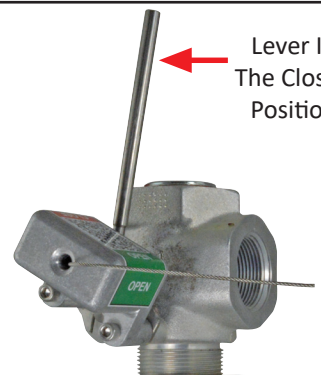

⚠ WARNING

Since there is strong spring force on the operating lever, avoid getting in the way of the lever as it moves to the closed position. Failure to do so could result in personal injury.

While this information is presented in good faith and believed to be accurate, Individuals using this literature must exercise their independent judgment in evaluating product selection and determining product appropriateness for their particular purpose, system requirements and certifications. The manufacturer reserves the right to change product designs and specifications without notice.

Operation Of The A125-45A, A125-60A, A15-45A, & A15-60A Valves

To Open Valve

1. Always open the internal valve before opening any other valves in the line.
2. Move the lever to the half-open (rapid equalization) position (Operational Schematic Figure 1, View #2 - A120, A125, A15 IOM) to equalize pressure. When the main poppet clicks open, move the operating lever fully open.
3. Open other line valves slowly to avoid sudden surges which could slug the excess flow valve shut.
4. If the excess flow valve does close, close the nearest downstream valve. Move the internal valve's operating lever back to the rapid equalizing position (outlined in step 2) and wait for the valve to click open. Then move the operating lever fully open and slowly open the downstream valve.

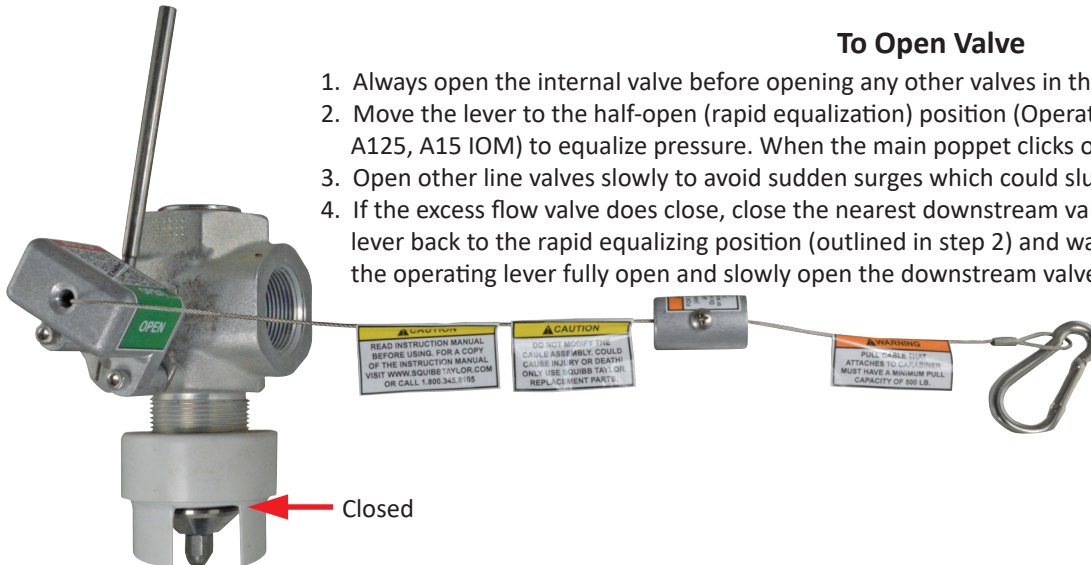

CAUTION

DO NOT Force open lever against NH₃ Nurse Tank flow before pressure is equalized on each side of the main valve disk.
DO NOT Modify the Cable/Carabinier Assembly. Could cause Injury or Death! Only Use Squibb Taylor Replacement Parts.

To Close Valve

Pull on the Loop End of the Cable. The plunger will retract to allow the lever to move. The closing spring causes the valve to close.

The operator must always be aware of where the remote closure controls are located and know how to operate the controls if an emergency requires valve closure. When finished, make a habit of closing the internal valve from the remote closure point, thus checking to see that the control actually is capable of closing the valve and operating correctly.

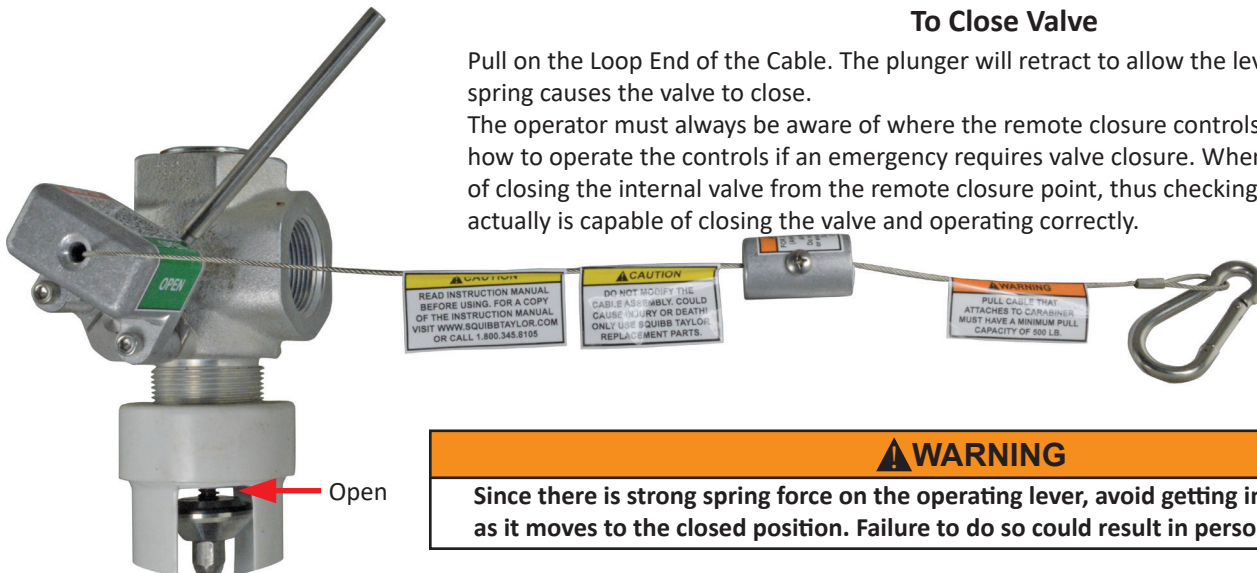

WARNING

Since there is strong spring force on the operating lever, avoid getting in the way of the lever as it moves to the closed position. Failure to do so could result in personal injury.

Assembled Valve & Manual Release is now an Emergency Shutoff Valve for Anhydrous Ammonia (NH₃) Nurse Tank.

- Test For Proper Operation @ A Minimum Of Once A Month & Daily During Field Application Periods.
- Always Test Operation Before Sending To Field For Use.

Maintenance

WARNING

ONLY PERSONNEL TRAINED IN THE PROPER PROCEDURES, CODES, STANDARDS & REGULATIONS OF THE ANHYDROUS AMMONIA INDUSTRY SHALL PERFORM MAINTENANCE ON THIS EQUIPMENT. Before starting any type of maintenance, close off the A120MAN valve(s) & remove all Anhydrous Ammonia (NH₃) pressure from the Outlet of the Internal Shutoff Valve. If maintenance or repairs are to be made on the internal valve(s), refer to the Instruction Manual for the particular valve model. An A120MAN manual release that has been disassembled must be tested for proper operation before being returned to service.

CHECK ACTUATOR PERIODICALLY FOR THE FOLLOWING:

1. See that the manual release is properly connected, works freely and is not worn.
2. Make sure there are no obstructions or debris to block the valve and lever from closing.
3. Make sure that both cables move freely inside the Break-Away Coupling.

While this information is presented in good faith and believed to be accurate, Individuals using this literature must exercise their independent judgment in evaluating product selection and determining product appropriateness for their particular purpose, system requirements and certifications. The manufacturer reserves the right to change product designs and specifications without notice.

Replacement Of The Break-Away Insert

1. Remove the Phillips Head Screw from the Break-Away Coupling.

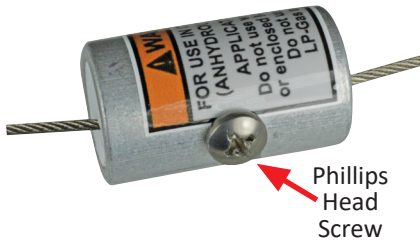

2. Remove the Break-Away Insert from the Break-Away Coupling. Grasp the outside of the Coupling & push on the Break-Away Insert until it is free of the Coupling.



3. Make sure that you push the Break-Away Insert out of the Coupling on the side that is attached to the Manual Release.

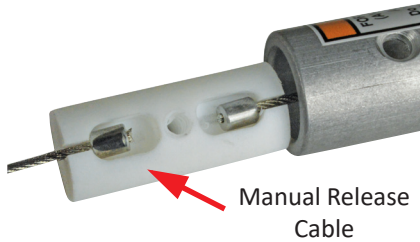

4. Remove the Manual Release cable from the Break-Away Insert.



5. Remove the Looped Cable from the Break-Away Insert.

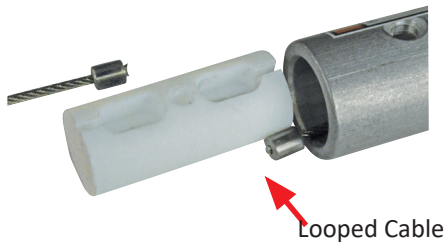

6. Discard the Break-Away Insert. Inspect the Crimped Ends of the Cables for wear or deterioration.

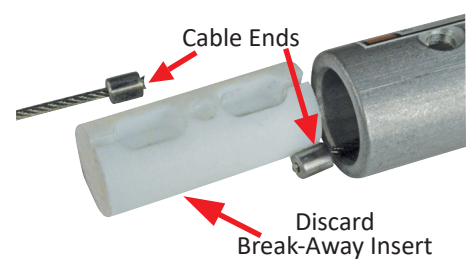

7. Replace the Looped Cable End back into the New Break-Away Insert.

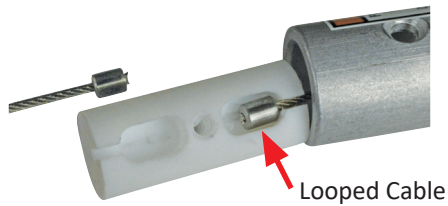

8. Replace the Manual Release Cable End back into the new Break-Away Insert.

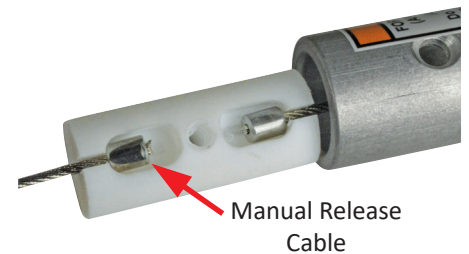

9. Keep both cables spread apart from the center of the Break-Away Insert. Slide the Coupling over the Break-Away Insert, just enough to cover the ends of the cables.



10. Line the Big Hole in the Coupling up with the hole that is in the Break-Away Insert.



11. Replace the Phillips Head Screw as shown. Tighten the screw with a Phillips Head Screw driver.



12. Check both cables. Make sure that each cable rotates in & out.



Note:

The Break-Away Insert should be replaced after a Break-Away.

⚠ CAUTION

DO NOT Modify the Cable/Carabiner Assembly. Could cause Injury or Death! Only Use Squibb Taylor Replacement Parts.

While this information is presented in good faith and believed to be accurate, Individuals using this literature must exercise their independent judgment in evaluating product selection and determining product appropriateness for their particular purpose, system requirements and certifications. The manufacturer reserves the right to change product designs and specifications without notice.

Replacement Remote Manual Release Valve & Assemblies

Item Number	Part Number	Tank Connection	Valve Outlet	Body	Excess Flow Rate
111901	A120-45AM	1 1/4" MNPT	1 1/4" FNPT	Angle	45 GPM
111903	A120-45SM			Straight	
111906	A125-45AM	1 1/2" MNPT	1 1/4" FNPT	Angle	45 GPM
111908	A125-45SM			Straight	
111911	A125-60AM			Angle	60 GPM
111913	A125-60SM			Straight	
111916	A15-45AM	1 1/2" MNPT	1 1/2" FNPT	Angle	45 GPM
111918	A15-45SM			Straight	
111921	A15-60AM			Angle	60 GPM
111923	A15-60SM			Straight	

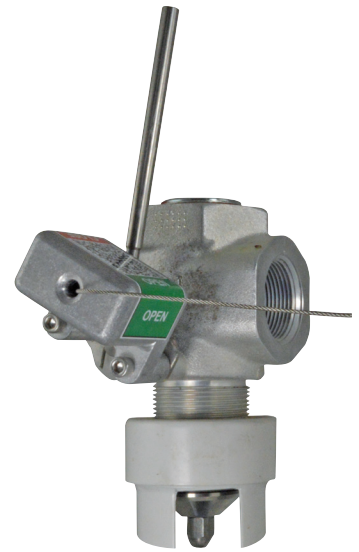

A120-45AM

WARNING - For Anhydrous Ammonia (NH3) Service Only

Replacement Nurse Tank Valves

Item Number	Part Number	Tank Connection	Valve Outlet	Body	Excess Flow Rate
111904	A120-45A	1 1/4" MNPT	1 1/4" FNPT	Angle or Straight	45 GPM
111909	A125-45A	1 1/2" MNPT	1 1/4" FNPT		45 GPM
111914	A125-60A				60 GPM
111919	A15-45A	1 1/2" MNPT	1 1/2" FNPT		45 GPM
111924	A15-60A			60 GPM	



A120-45A

WARNING - For Anhydrous Ammonia (NH3) Service Only

Replacement Parts

Item Number	Part Number	Part Description
111930	LB-1	Latch Block Break-Away Assembly
111931	LC	Lanyard & Carabinier Kit
111932	BAI	Break-Away Insert

WARNING - For Anhydrous Ammonia (NH3) Service Only



LB-1



LC



BAI

While this information is presented in good faith and believed to be accurate, individuals using this literature must exercise their independent judgment in evaluating product selection and determining product appropriateness for their particular purpose, system requirements and certifications. The manufacturer reserves the right to change product designs and specifications without notice.



A120, A125, A15 SERIES THREADED INTERNAL VALVE INSTALLATION AND OPERATING MANUAL (ANHYDROUS AMMONIA ONLY)

10480 Shady Trail #106
Dallas, TX 75220
800-345-8105/214-357-4591
Fax 214-357-5923
3094 Connahbrook,
Memphis, TN 38116
800-238-2664/901-332-5272
Fax 901-346-1790
www.squibbtaylor.com

!WARNING!

Failure to follow these instructions or to properly install and maintain this equipment could result in property damage and personal injury or death.

Install, operate, and maintain all equipment in accordance with federal, state, and local codes and according to the manufacturer's instructions. The installation in most states must also comply with ANSI Standard K61.1/CGA 2.1.

Only personnel trained in the proper procedures, codes, standards, and regulations of the Anhydrous Ammonia industry should install and service this equipment.

The internal valve must be closed except during product transfer. A line break downstream of a valve may not actuate the excess flow valve. If any break occurs in the system or if the excess flow valve closes, the system should be shut down immediately.

Scope of the Manual

This manual covers instructions for the A120, A125 and A15 series threaded internal valves.

Introduction

The A120, A125 and A15 internal valve is intended as a main valve for NH₃ nurse tanks. It can also be used on in-line installations. Designed for NH₃ (Anhydrous Ammonia) only.

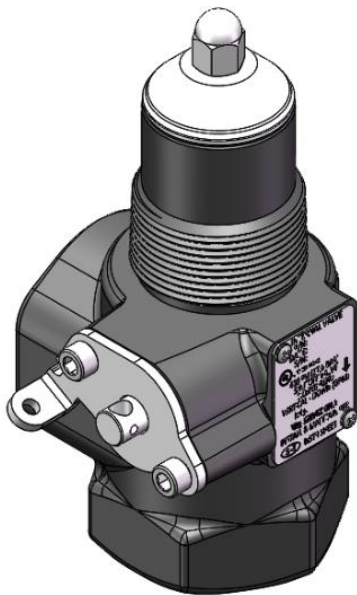

Features

- **Equalization bleed area** - Provides high bleed flow for quick opening.
- **Durable Design:**
 - Stainless poppet and stem with hardened, low friction coating operates smoothly for a long wear life
 - Integral travel stop
 - Stainless steel roller cam
- **Excess Flow Closure** - Functions when flow exceeds the rated capacity of the valve.
- **Back Check Feature** - Allows reverse flow filling with or without actuator device in valve open position.
- **Spring loaded Polytetrafluoroethylene (PTFE) stub shaft packing**
- **Rulon® bushings** at critical wear points.
- **Air Open/Close valve actuators** can be used.
- **12-volt electrical close only valve actuators** can be used.
- **Cable Actuation** can be used.

Specifications

Specifications

Body Size and End Connection Styles:

Inlet: 1-1/4" MNPT or 1-1/2" MNPT
Outlet: 1-1/4" FNPT or 1-1/2" FNPT

Maximum Allowable Inlet Pressure:

400 psig / 27.6 bar WOG

Excess Flow Springs:

GPM (Vertical down): 45, 60

Temperature Capabilities:

-20° to 150°F / -29° to 66°C

Approximate weight:

5 pounds / 2.25 kg

Body Materials:

A120: Stainless Steel
A125, A15: Ductile Iron

The contents of this publication are for informational purposes only. While every effort has been made to ensure accuracy, these contents are not to be construed as warranties or guarantees, expressed or implied, regarding the products or services described herein or for their use or applicability. The manufacturer reserves the right to modify or improve the designs or specifications of such products at any time without notice.

A120, A125, A15

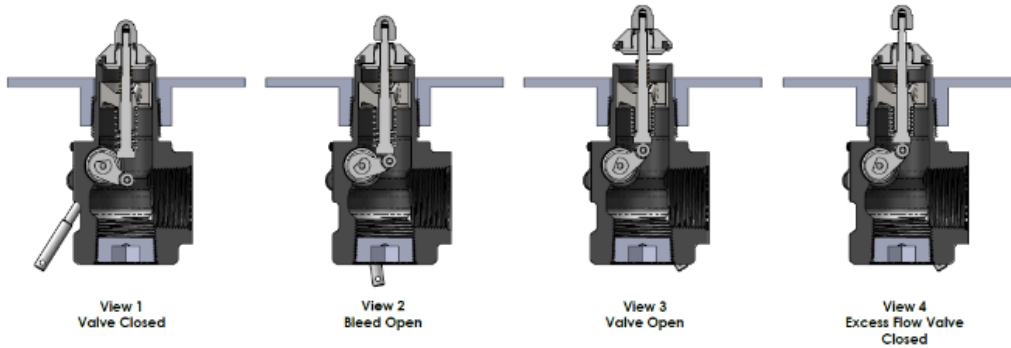

Figure 1: Operational Schematic

Installation

Mounting and Piping

The A120, A125 and A15 internal valves must be installed in a nurse tank.

!CAUTION!

Do not install the valve in any piping tending to restrict the valve inlet or outlet downstream as this may prevent the excess flow valve from closing.

Do not install the valve with such extreme torque that the coupling can cut threads into the valve. This could cause valve distortion and affect the internal working parts.

Use an appropriate pipe compound on the male threads of the internal valve and pipeline. Install the valve into the coupling hand tight, and then wrench tighten it for approximately two additional turns. Larger size valves may require an additional amount of torque to obtain a leak-free connection.

After installation, check all joints for leaks using a suitable leak detector solution such as a low temp leak detector before putting the valve into service.

The valves feature a break off which is intended to permit the valve body to shear off in an accident, leaving the valve seat in the tank. **The break off section is designed for container installations and will probably not provide shear protection if the valve is installed in a pipeline.**

A hydrostatic relief valve does not need to be installed adjacent to the valve since the internal valve relieves excessive line pressure into the tank.

Selectively Filling Manifolded Tanks

Internal valves provide positive shutoff in only one direction, from out of the tank to downstream of the valve. The internal valves are designed to allow gas to flow into a tank when the downstream line pressure exceeds tank pressure. If you want to selectively fill one or more of the other tanks in a tank manifold system, you must place a positive shutoff valve downstream of

the internal valve, otherwise, all tanks will be filled at the same time and at about the same rate.

Excess Flow Protection

The internal valve contains an excess flow function, or "integral excess flow valve", that is designed to close when the flow exceeds the flow rating established by the manufacturer. Likewise, if the internal valve is installed on a stationary tank or in the related downstream piping system, the integral excess flow valve can provide protection against an unintentional release of hazardous materials in the event that a pump or piping attached directly to the internal valve is sheared off before the first valve, pump, or fitting downstream of the internal valve, provided that the flow of product through the internal valve reaches the rated flow specified by the manufacturer.

Restrictions incorporated in the discharge system downstream of the A120, A125 or A15 may include but not limited to fittings, pipe and hose length and dimensions, branching, elbows, reductions in pipe diameter, or a number of other inline valves or fittings. Low operating pressure may be a result of ambient temperature, or a partially closed valve downstream from the integral excess flow valve; this can restrict the rate of flow through the internal valve below the level necessary to actuate the integral excess flow valve.

Therefore, DO NOT USE the excess flow function of the internal valve for the purpose of providing protection against the discharge of hazardous materials. In the event of a ruptured hose or piping at a point in the discharge system downstream from the internal valve, the excess flow feature is designed to close upon a significant increase in differential pressure or flow.

The internal valve is designed with an internal bleed feature for equalization of pressure. After the integral excess flow valve closes, the leakage through the bleed must be controlled or a hazard can be created. For this reason the operator must be familiar with the closure controls for the internal valve and must close the internal valve immediately after the integral excess flow valve closes.

Failure to follow this warning could result in death, serious personal injury or property damage.

A120, A125, A15

!WARNING!

If the A120, A125 or A15 valve is installed in a pressurized tank, ensure that the line pressure is 0 psi (0 bar) prior to beginning installation of any latch or actuator.

Actuators

The remote operating control system for the internal valve is extremely important, and it must be installed to conform to the applicable codes.

Cable controls, pneumatic and 12-volt electric actuation is available. It may also be possible to use actuators from other manufacturers. The instruction manuals for the actuator systems show how to install.

Note

The use of non-approved actuators may result in leakage of the gland packing caused by premature wear. In addition to premature wear, the use of non-approved actuators may result in lower than expected flow rates and possible leakage across the valve seats.

!CAUTION!

If using cable actuation, the internal valve's closing spring is not designed to overcome drag in the control linkage in order to close the valve. Depending upon the control system used, an external spring or positive closing linkage may be needed. Be sure the control system is installed to prevent binding that could cause the valve to stick in the open position.

Cable Operation - The operating linkage should stroke the valve operating lever from the fully closed position to within a minimum of 2° of the full open position. Too short an operating lever stroke will result in premature excess flow valve closure. The cable control linkage can be attached through the hole in the operating lever to provide remote valve operation.

Remote Release - To install the ME990-10-902 latch mechanisms, first release the downstream pressure. **Failure to do so could result in personal injury.** Remove the operating lever and take off the cover plate by removing the cap screws. The new cover plate/latch assembly can be attached to the valve with the same cap screws. Tighten the screws to 25 to 30-inch-pounds (33.9 to 40.7 N·m) torque.

A cable must be ran from the pull ring on the latch to the release handle. The cable must be taut for proper operation, and the hookup may require sufficient pulleys to keep the cable away from the side of the tank. Pulling the release handle allows the manual operating lever to return to the closed position. The fusible link in the mechanism will melt if exposed to fire, allowing the valve to close.

When closing the valve manually, pull back on the cable attached to the release mechanism to permit the valve lever to close.

!WARNING!

Since there is strong spring force on the operating lever, avoid getting in the way of the lever as it moves to the closed position. Failure to do so could result in personal injury.

Principle of Operation

Refer to the operational schematic (Figure 1, View 1). The valve is held closed by both tank pressure and the valve's closing spring. There is no leakage past the resilient seals in the poppet to the valve outlet in this position.

The valve is opened by moving the operating lever to approximately midpoint in its 70° travel (Figure 1, View 2). This allows the cam to place the rapid equalization portion of the valve stem in the pilot opening, permitting a larger amount of product to bleed downstream than if the operating lever were moved to the full open position.

When tank and downstream pressures have equalized in the bleed position, (after a few seconds), the excess flow spring pushes open the main poppet (Figure 1, View 3) and the operating lever can be moved to the full open position.

If tank pressure is greater than the valve's outlet pressure, the main poppet will remain in the closed position. If valve outlet piping is closed off by other valves, however, product bleeding through the pilot will increase until it nearly equals tank pressure and the main poppet opens.



WARNING: These products contain a chemical known to the state of California to cause cancer and birth defects or reproductive harm

Note

The main poppet will not open if valve outlet piping is not closed off so that the outlet pressure can approach tank pressure.

Once the main poppet opens, a flow greater than the valve's excess flow spring rating or a sufficient surge in flow forces the main poppet closed against the excess flow spring (Figure 1, View 4). The pilot valve allows a small amount of product to bleed, but much less than (Figure 1, View 2) where the rapid equalization portion of the stem is placed in the pilot opening. When the operating lever is moved to the closed position, the valve closes completely and seals tightly (Figure 1, View 1).

A120, A125, A15

Operation

Since the A120, A125, and A15 internal valve will not open unless the downstream pressure can build-up to equal the inlet pressure, an operating sequence that assures equalization is important.

Follow these steps:

1. Always open the internal valve before opening any other valves in the line.
2. Move the lever to the half-open (rapid equalization) position (Operational Schematic Figure 1, View #2) to equalize pressure. When the main poppet clicks open, move the operating lever fully open.
3. Open other line valves slowly to avoid sudden surges which could slug the excess flow valve shut.
4. If the excess flow valve does close, close the nearest downstream valve. Move the internal valve's operating lever back to the rapid equalizing position (outlined in step 3) and wait for the valve to click open. Then move the operating lever fully open and slowly open the downstream valve.
5. All valves should be completely open when applying NH₃ (Anhydrous Ammonia). (**Throttling type valves could prevent the excess flow valve from closing when required.**) Also make sure there are no other restrictions downstream of any excess flow.
6. The operator must always be aware of where the remote closure controls are located and know how to operate the controls if an emergency requires valve closure. When finished, make a habit of closing the internal valve from the remote closure point, thus checking to see that the control actually is capable of closing the valve and operating correctly.
7. The valve does not need to be open when backfilling through the valve to fill the tank.

Troubleshooting

Internal Valve Will Not Open: This could be due to leakage downstream or from excessive wear in the internal valve. If excessive volume is in the downstream system, a longer time is required to equalize the pressures (tank and downstream). To determine if the valve pilot seat is opening, install a gauge downstream of the valve, operate the valve actuator; if pressure does not build up to the tank pressure, the valve pilot seat is not open. If the pilot is not opening, it may be plugged with dirt or some internal part may be broken.

Premature Valve Closure: This can be caused from engaging the pump too soon, by an underrated excess flow valve spring, or by an improperly connected internal valve operating lever which does not fully open the valve. The trouble could also be from a valve that has its inlet port obstructed or from sudden line surges. In order to check the valve opening travel, operate the lever manually

to the full travel, wait until valve opens (usually about 15 seconds), then engage the pump. If the excess flow closes, the points mentioned above should be investigated.

Internal Valve Will Not Close: The stub shaft could be binding or the stem could be bent in the valve. Before disassembling the valve, check the actuator mechanism to see that it operates freely by disconnecting it from the valve lever and cycling it several times. Also, operate the valve lever manually. If it sticks in the open position, the packing and bushings should be replaced. This should free the operating mechanism if the valve has not been damaged internally. Refer to the "Maintenance" section.

Low Flow Capacity: This could be caused by an undersized internal valve, undersized or long downstream piping, plugged screens or some other restriction in the downstream system.

Maintenance

Refer to Figures 3, 4, and 5.

!CAUTION!

Do not use these internal valves if they leak, fail to work properly or have been damaged or have missing parts. Prompt repairs should be made by a properly trained serviceman. Continued use without repair can create a hazardous situation which could result in serious or fatal personal injury or property damage.

A simple preventative maintenance program for the valve and its controls will eliminate many potential problems.

The manufacturer recommends these steps be conducted once a month. Also follow all local regulations.

1. Regularly inspect the actuation of the valve to see that it operates freely and that there is no leakage around the stub shaft. If there is leakage or sticking, the packing should be replaced, see "Disassembly" section.
2. Check for tight closure of the valve seal. Any detected leakage, which is normally caused by seal wear or dirt, scale or debris embedded in the seal, requires that the internal valve be removed from service and repaired. Repair most often requires the replacement of valve seals. To check for leakage:
 - a. Close the internal valve and exhaust downstream pressure. Close the first valve downstream from the internal valve, and note any pressure buildup, using a pressure gauge, between the closed valve and the internal valve. If piping is cold, allow it to warm to ambient temperature.
3. All operating controls should be inspected, cleaned and maintained. The controls should be checked to see that they fully open but not over travel the

A120, A125, A15

4. internal valve operating lever and operate freely to close the valve.
5. Standard construction internal valves must be removed if the container is to be steam cleaned. Heat can damage the valve's seats and seals.
6. Standard construction internal valves are not designed for water service. Immediately after a container is hydrostatically tested, remove all water and allow the container to thoroughly dry out.

Parts Ordering

Important

Use only genuine replacement parts. Components that are not supplied by the manufacturer should not, under any circumstances, be used in any valve, because they might adversely affect the performance of the valve, and could give rise to personal injury and property damage or death.

When corresponding about this equipment, always reference the equipment model or series number found on the nameplate.

Valve	A125
Available Service Kit	A125-12-SRK
	A125-12-VRK
	A125-12-PGA
	A125-12-PRK

SRK – Seal Repair Kit

VRK – Valve Repair Kit

PGA – Packing Gland Assembly

PRK – Packing Repair Kit

See parts list for corresponding parts and service kit components.

Parts List for A125			A125-12-		
Ref. #	Description	Qty.	SRK	VRK	PGA
1	Body	1			
2	Valve Stem	1		✓	
3	Lower Washer	1		✓	
4	Valve Spring	1		✓	
5	Stem Guide	1		✓	
6	Upper Stem Washer	1		✓	
7	Excess Flow Spring - 45 GPM (Orange) Excess Flow Spring - 60 GPM (Red)	1			
8	Valve Holder	1		✓	
9	Excess Flow Seal	1	✓	✓	
10	Valve Seal	1	✓	✓	
11	Seal Retainer	1		✓	
12	Nut	1		✓	
13	Gland	1		✓	✓
14	Packing Spring	1		✓	✓
15	Packing Spacer	1	✓	✓	✓
16	Male V-Packing	1	✓	✓	✓
17	V-Packing	3	✓	✓	✓
18	Female V-Packing	1	✓	✓	✓
19	Bonnet Stem	1		✓	✓
20	Packing Spacer	1		✓	✓
21	Stem Bushing	1	✓	✓	✓
22	O-Ring, #2-119	1	✓	✓	✓
23	Cam	1		✓	✓
24	Roller	1		✓	✓
25	Nylon Bearing	1		✓	✓
26	Cam Rivet	1		✓	✓
27	Cam Screw	1		✓	✓
28	Packing Retainer	1		✓	
29	Flat Washer	2			
30	1/4"-28 Socket Head Cap Screw	2		✓	
31	1/4" NPT Plug	1			
32	Flush NPT Plug	1			
33	Nameplate	1			
34	Nameplate Screw	2			

ITEM NUMBER	PART NUMBER	INLET	OUTLET	GPM	CONFIGURATION
111900	A120-45	1 1/4	1 1/4	45	Angle
111902	A120S-45	1 1/4	1 1/4	45	Straight
111905	A125-45	1 1/2	1 1/4	45	Angle
111907	A125S-45	1 1/2	1 1/4	45	Straight
111910	A125-60	1 1/2	1 1/4	60	Angle
111912	A125S-60	1 1/2	1 1/4	60	Straight
111915	A15-45	1 1/2	1 1/2	45	Angle
111917	A15S-45	1 1/2	1 1/2	45	Straight
111920	A15-60	1 1/2	1 1/2	60	Angle
111922	A15S-60	1 1/2	1 1/2	60	Straight

A120, A125, A15

