

Installation, Operation & Maintenance Instructions for the A480N & A482N Series of NH₃ Nurse Tank Valves

July 2019

Form FVC074 Rev M

IMPORTANT: KEEP THIS DOCUMENT WITH THE PRODUCT UNTIL IT REACHES THE END USER.

WARNING!

1. Improper Anhydrous Ammonia (NH₃) Application system design, or the improper selection and use of the tank valves and excess flow valves in NH₃ application systems can result in death, personal injury and/or property damage due to unintentional NH₃ releases. Exposure to NH₃ releases can cause injury or death by, for example, chemical burns, blindness, lung damage and an immediate inability to see or drive a vehicle in the attempt to get away from the released NH₃ cloud.
2. All NH₃ application systems should be designed by persons with the technical skill and understanding of how the excess flow valve, associated equipment and entire system operates. Persons with the technical skill and understanding should test the system under all conditions that are likely to occur, to make sure that the excess flow valve operates as expected.

The person designing the system, with the technical skill and understanding, shall take into consideration, but not be limited to, the following criteria;

- a. Expected flow rate.
 - b. System plumbing effects, especially teeing tanks together.
 - c. Tractor speed.
 - d. Downstream restriction effects.
 - e. Ambient temperature at the time of application.
 - f. Tank temperature.
 - g. Volume and pressure at the time of application.
3. Even when properly selected and used, an excess flow valve may not operate or stop flow in certain lower flow NH₃ leak situations. **The Excess flow safety device used in this product will close ONLY if the rated flow rate is achieved through the valve. Downstream restrictions, partial breaks, teeing tanks together and/or low tank pressure can result in failure to achieve the excess flow rate and the excess flow check WILL NOT CLOSE.** The end user should have a secondary means available to stop flow or prevent injury should a leak not be stopped by the excess flow valve.
 4. An emergency shut off device, which can be remotely actuated by the vehicle driver, should be an integral part of the system and available to stop NH₃ flow in the event it is not stopped by the excess flow valve. Additionally, personal safety equipment such as an Emergency Escape Breathing Device and a plan to isolate the vehicle cabin by, for example, turning off ventilation or air conditioning, are important safety precautions.
 5. Before installation or removal of any tank valve, the system must be purged of all product.
 6. Personal Protective Equipment (PPE), safety gloves, goggles and clothing should be worn.
 7. For proper handling and storage of NH₃ refer to ANSI K61.1, CGA G-2.1 Standards, or Local Authorities having jurisdiction.
 8. An abundant supply of fresh water should be available to provide immediate first aid treatment for exposure to NH₃.
 9. To prevent the accidental opening of any valve, never grasp or carry a valve by its Handwheel ① or handle.
 10. To ensure a long term and safe operation, the manufacturer recommends that under normal service conditions this product be inspected at least once every season and be repaired or replaced as required.

While this information is presented in good faith and believed to be accurate, Individuals using this literature must exercise their independent judgment in evaluating product selection and determining product appropriateness for their particular purpose, system requirements and certifications. The manufacturer reserves the right to change product designs and specifications without notice.

11. Closure of the excess flow check in the valve will not totally stop the flow of NH₃ since the check disk has a small opening in it to allow the check disk to automatically reset.

Piping should not allow one withdrawal valve to "back feed" the other. Appropriately located back checks must be installed.

The operation of the excess flow device should be tested before every season.

- NOTE:** The A48XN-60 Excess Flow will close at approximately 60 GPM of Liquid NH₃. Indicated on the information disc ⑨
The A48XN-45 Excess Flow will close at approximately 45 GPM of Liquid NH₃. Indicated on the information disc ⑨

The 60 GPM & 45 GPM excess flow offering gives the user a choice to match the excess flow setting as close as possible to the maximum expected Liquid NH₃ flow rate to be used. For example, if 30 GPM of Liquid NH₃ is the highest flow rate the application will use, then choose the A48XN-45 (45 GPM Liquid NH₃).

Tools Required

Safety Equipment (i.e. Gloves, Goggles, and Clothing), 12" Adjustable Wrench, 1/4" Diameter Drift Pin, small Ball Peen Hammer, 7/16" Open-End or Boxed-End Wrench, and Torque Wrench.

Installation / Removal

1. To prevent unexpected pressure buildup in the system, always keep the Valve Handle in the OPEN POSITION during installation or removal.
2. Before installation or after removal, check the Excess Flow Disk for free operation between FULLY CLOSED & FULLY OPEN.
3. Inspect the Valve Seat for hardening or cracking and replace if either is observed.

Operation

1. Open the Valve slowly to avoid the Excess Flow Check from closing. If it does, you will hear a "click" and flow will be slowed to a very small amount.
2. If the Excess Flow Disk is tripped, close the Valve. This will allow the Excess Flow Check to reset automatically, then you may try again to open the valve slowly.
3. During storage, temperature changes can cause the Valve to "seep" so periodic inspection and retightening may be required.
4. During long-term storage, the Valve outlet may be capped to prevent seepage issues.

Typical Method for Testing The Excess Flow Shut-Off

1. Connect a test hose to the nurse tank. The test hose should be the same length and size as the normal hose used in the field and have a ball valve at the far end, followed by a bleeding system that can be submerged in water without restricting FULL OPEN flow.
NOTE: This test should be conducted at tank pressures representative of the lowest application tank pressure.
2. Close the ball valve, open the withdrawal valve, submerge the bleed system at least 12 inches deep in the water, crack open ball valve for 10 seconds to fill hose with liquid, shut ball valve, then quickly open the ball valve FULL OPEN.
3. After a brief burst of flow, the Excess Flow Device should close, then the flow should be reduced to a small amount. After flow has reduced, close the withdrawal valve then the test hose may be bled down safely and removed from the withdrawal valve.
WARNING: If the excess flow did not close, then use a valve with a LOWER excess flow rate.

Disassemble Procedure for Repair

1. With the Valve secured in a bench-mounted vise, remove the Bonnet ⑤ from the Body ②, which will expose the complete Bonnet ⑤ and Stem Assembly. NOTE: It is important to inspect the Disk Holder ⑨ rotation. If it does not rotate freely, do not return the Valve to service, but consult your local dealer for instructions. Remove the old O-Ring ④.
2. Now secure the Bonnet ⑤ in the vise and remove the Handwheel Nut ⑬ and the Disc Nut ⑳.

While this information is presented in good faith and believed to be accurate, Individuals using this literature must exercise their independent judgment in evaluating product selection and determining product appropriateness for their particular purpose, system requirements and certifications. The manufacturer reserves the right to change product designs and specifications without notice.

Disassemble Procedure for Repair Cont.

3. Remove the Disc Washer ⑳, the Disc ㉑, the Washer ⑫ and the Handwheel ⑪.
4. Remove the Packing Nut ⑧, the Chevron Packing ⑭, the Male Adapter ⑰, the ID Tag ⑨ and the Packing Spring ⑥ over the end of the Stem ⑩.
5. Rotate the Stem ⑩ clockwise, using the Handwheel ⑪ if necessary, until the Stem ⑩ is disengaged from the Bonnet ⑤. Remove the old Gasket ⑦.
6. Before re-assembly, clean and inspect the Valve Seat. Clean all metal components with a solvent and wipe or blow dry with air.

Assembly Procedure

NOTE: The degree of assembly depends upon the type of repair to be performed.

1. Install the Disc ㉑, the Disc Washer ㉒ and the Disc Nut ㉓ to the Disk Holder ⑲. Secure the Disc Nut ㉓ to the threads of the Disk Holder ⑲ with a center-punch mark at the thread interface.
2. Lubricate the Stem threads ⑱ with a good quality grease and install the Stem ⑩ into the Bonnet ⑤ until the Disk Holder ⑲ rests against the bottom of the Bonnet ⑤.
3. With the Bonnet ⑤ and the Stem Assembly secured in a bench-mounted vise, install the Gasket ⑦ and the Packing Spring ⑥.
4. Replace the O-Ring ⑮ in the groove of the Packing Nut ⑧.
5. Install the Chevron Packing ⑭ and the Male Adapter ⑰ into Packing Nut ⑧.
6. Lubricate the exposed surface of the Stem ⑩ with John Crane Style 279A Packing Lubricant or equivalent.
7. Place the Packing Nut ⑧ (with the packing in place) over the Stem ⑩ and engage the Bonnet threads. Tighten the Packing Nut with a torque wrench to 55 ft.-lbs.
8. Secure the Body ② in the vise. Place the Body O-Ring ④ over the bonnet threads and lubricate the threads with a good quality grease.
9. Install Bonnet Assembly into the Body and tighten with a torque wrench to 95 ft.-lbs.
10. Install the Handwheel ⑪ install Washer ⑫ and tighten the Handwheel Nut ⑬ onto the Stem ⑩.
11. Check the Stem Packing and Valve Seat for leaks. Operate the Handwheel ⑪ to FULL OPEN and to FULL CLOSED to ensure smooth operation.
12. Check the freedom of movement of the Excess Flow assembly ① by depressing the disc 2 or 3 times.

User Safety Responsibility Statement for All Parker Products

FAILURE OR IMPROPER SELECTION OR IMPROPER USE OF THE PRODUCTS DESCRIBED HEREIN OR RELATED ITEMS CAN CAUSE DEATH, PERSONAL INJURY AND PROPERTY DAMAGE.

- This document and other information from Parker-Hannifin Corporation, its subsidiaries and authorized distributors provide product or system options for further investigation by users having technical expertise.
- The user, through its own analysis and testing, is solely responsible for making the final selection of the system and components and assuring that all performance, endurance, maintenance, safety and warning requirements of the application are met. The user must analyze all aspects of the application, follow applicable industry standards, and follow the information concerning the product in the current product catalog and in any other materials provided from Parker or its subsidiaries or authorized distributors.

To the extent that Parker or its subsidiaries or authorized distributors provide component or system options based upon data or specifications provided by the user, the user is responsible for determining that such data and specifications are suitable and sufficient for all applications and reasonably foreseeable uses of the components or systems.

While this information is presented in good faith and believed to be accurate, Individuals using this literature must exercise their independent judgment in evaluating product selection and determining product appropriateness for their particular purpose, system requirements and certifications. The manufacturer reserves the right to change product designs and specifications without notice.

NO.	Part NO.	DESCRIPTION	QTY.
1	X	EXCESS FLOW ASSY	1
2	X	VALVE BODY	1
3	1327-1001	HYDROSTAT ASSEMBLY 350 PSI	1
4	P5-938-R0	O-RING	1
5	480-5002	BONNET	1
6	312-2019	SPRING	1
7	312-2016	GASKET	1
8	312-5017	PACKING NUT	1
9	X	INFORMATION DISC	1
10	480-5003	STEM	1
11	479-5013	HANDWHEEL	1
12	312-2014	WASHER	1
13	312-2015	HANDWHEEL NUT	1
14	X	EXPOSED SURFACE OF THE STEM	1
15	312-2020	O-RING	1
16	312-2005	CHEVRON PACKING	2
17	312-5006	MALE ADAPTER	1
18	X	STEM THREADS	1
19	480-5004	DISC HOLDER	1
20	312-3009	DISC	1
21	312-5010	DISC WASHER	1
22	312-2011	DISC NUT	1
23	308-2021	HANDLE WARNING STICKER	1

GENERAL INFORMATION
MATERIAL COMPONENTS
CARBON STEEL
DUCTILE IRON
STAINLESS STEEL
N674-70
ALUMINIUM
PTFE
NITRILE 03BN9AP

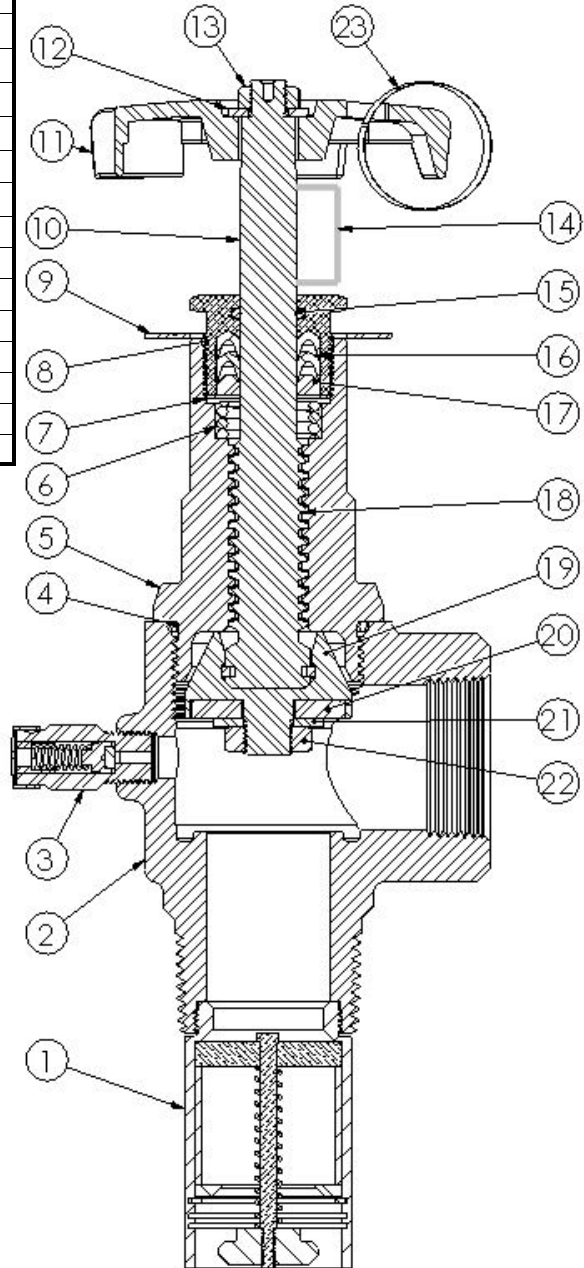

AVAILABLE KITS		
NUMBER	NAME & PARTS INCLUDED	ASSEMBLY PART NUMBERS
480-0022	SEAL KIT	④ ⑦ ⑮ ⑰ ⑳
S481-1100	STEM & DISC	⑩ ⑲ ⑳ ㉑ ㉒
480-25	BONNET ASSEMBLY KIT	④ ⑤ ⑥ ⑦ ⑧ ⑩ ⑮ ⑰ ⑱ ⑲ ⑳ ㉑ ㉒

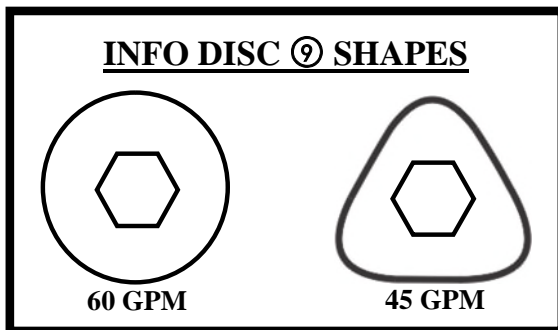

While this information is presented in good faith and believed to be accurate, Individuals using this literature must exercise their independent judgment in evaluating product selection and determining product appropriateness for their particular purpose, system requirements and certifications. The manufacturer reserves the right to change product designs and specifications without notice.