

Type P312 Air Cylinder and P313 Latch/Remote Release

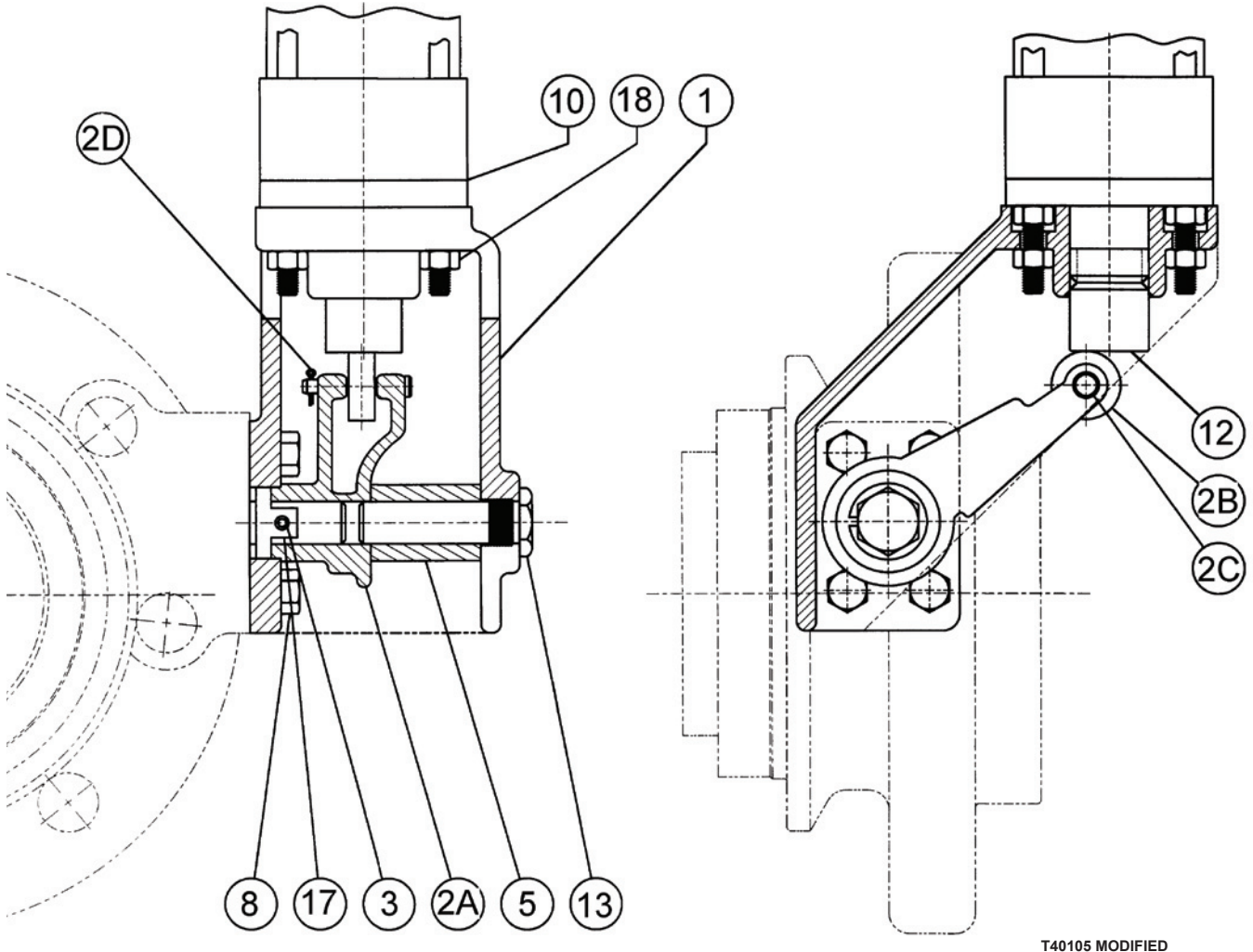

Figure 1. Type P312 Air Cylinder

Parts List

Key	Description	Part Number	Key	Description	Part Number
1	Mounting Bracket	T4010319042	8	Cap Screw (4 required)	T1133624052
2	Lever Assembly	T11341000A2	10	Air Cylinder	T1028999982
2A	Lever	T1133719042	12	Rod End	T1144535132
2B	Roller	T1028535132	13	Pin	T1134009012
2C	Pin	T1147328982	17	Collar	T1133435132
2D	Cotter	T1147428982	18	Nut (4 required)	1A309324122
3	Roll Pin	T1133528982	21	Instructional Manual	D450053T012
5	Spacer	T1133809012			



Type P312 Air Cylinder and P313 Latch/Remote Release

Replacement Parts Sheet
MCK 2157
January 2005

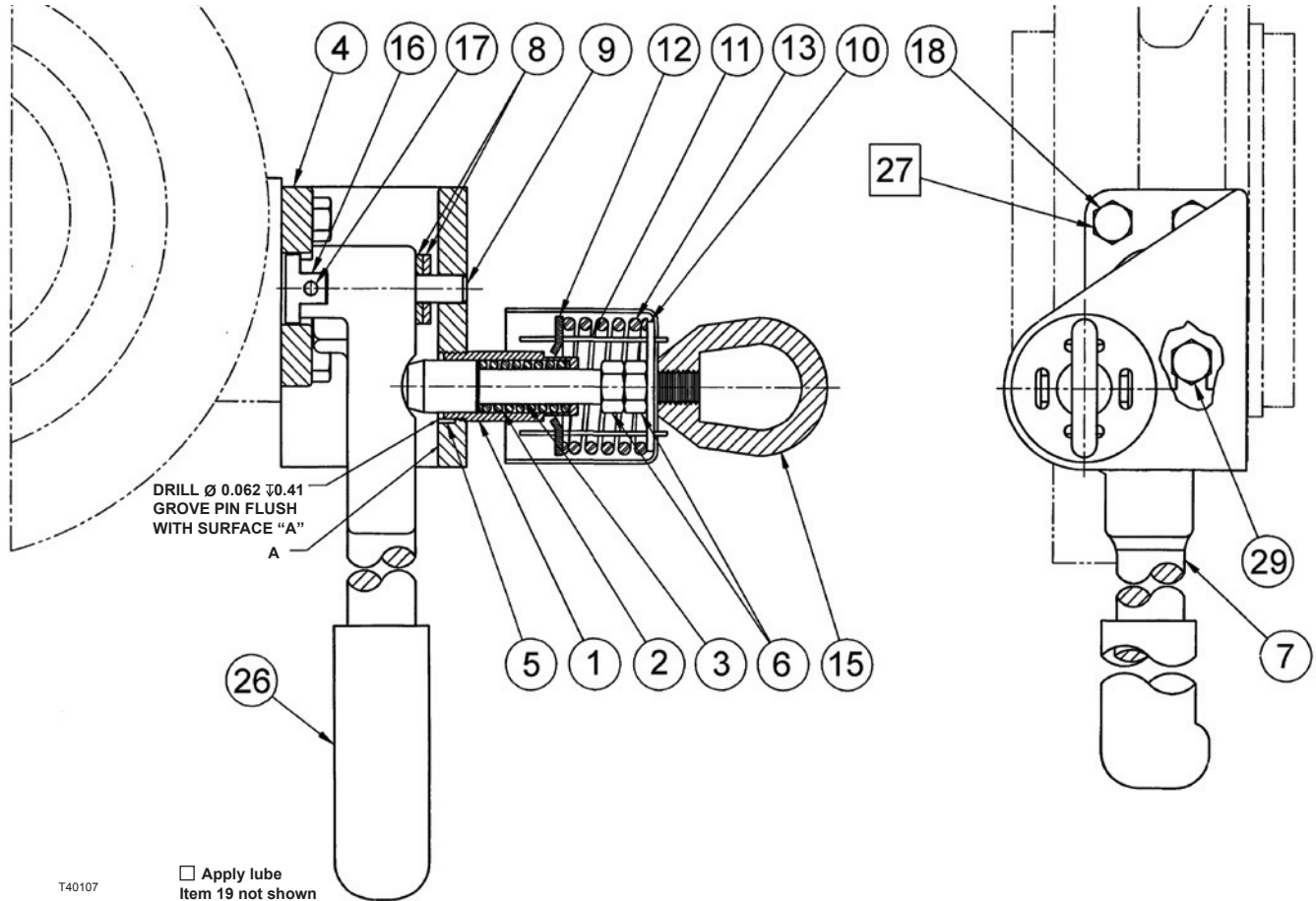

Figure 2. P313 Latch/Remote Release

Parts List

Key	Description	Part Number	Key	Description	Part Number
1	Stem Guide	T1135824102	13	Spring	T1136537082
2	Spring	T1135937022	14	Cover	T1068428982
3	Plunger	T1136035032	15	Eye Nut	1P111932992
4	Bracket	T2031119172	16	Collar	T1133435132
5	Groove Pin, 1/16 X 3/8	1D7991X0012	17	Roll Pin	T1133528982
6	Nut (2 required)	1A352424122	18	Cap Screw, Hex Head (2 required)	T1133624052
7	Lever	T2031319042	19	Instruction Tag	T1224806992
8	Washer (2 required)	T1136128992	26	Handgrip	T12928T0012
9	Roll Pin	T1136236402	27	Lub-5	1M523906992
10	Washer	T1136328982	28	Instruction Manual	D450053T012
11	Fusible Link (4 required)	1J157443992	29	Cap Screw, Hex Head	T1118724052
12	Washer	T1136428982			

Fisher and Fisher Regulators are marks owned by Fisher Controls International, LLC. The Emerson logo is a trademark and service mark of Emerson Electric Co. All other marks are the property of their respective owners.

The contents of this publication are presented for informational purposes only, and while every effort has been made to ensure their accuracy, they are not to be construed as warranties or guarantees, expressed or implied, regarding the products or services described herein or their use or applicability. We reserve the right to modify or improve the designs or specifications of such products at any time without notice.

Fisher does not assume responsibility for the selection, use or maintenance of any product. Responsibility for proper selection, use and maintenance of any Fisher product remains solely with the purchaser.

Emerson Process Management

Fisher Controls International, LLC.
P.O. Box 8004
McKinney, Texas 75070, USA
Telephone: 1 (800) 588-5853
Telephone: 1 (469) 293-4201