

Installation, Operation & Maintenance Manual

Model B177 External Automatic Bypass Valve



*Model B177 External
Automatic Bypass Valve*

Warning: (1) Periodic inspection and maintenance of Corken products is essential. (2) Inspection, maintenance and installation of Corken products must be made only by experienced, trained and qualified personnel. (3) Maintenance, use and installation of Corken products must comply with Corken instructions, applicable laws and safety standards (such as NFPA Pamphlet 58 for LP-Gas and ANSI K61.1-1972 for Anhydrous Ammonia). (4) Transfer of toxic, dangerous, flammable or explosive substances using Corken products is at user's risk and equipment should be operated only by qualified personnel according to applicable laws and safety standards.

Solutions beyond products...

CORKEN®

Warning

Install, use and maintain this equipment according to Corken's instructions and all applicable federal, state, local laws and codes. Periodic inspection and maintenance is essential.

Corken One Year Warranty

CORKEN, INC. warrants that its products will be free from defects in material and workmanship for a period of one year from date of installation, provided that the warranty shall not extend beyond twenty-four (24) months from the date of shipment from CORKEN. If a warranty dispute occurs, the DISTRIBUTOR may be required to provide CORKEN with proof of date of sale. The minimum requirement would be a copy of the DISTRIBUTOR'S invoice to the customer.

CORKEN products which fail within the warrant period due to defects in material or workmanship will be repaired or replaced at CORKEN's option, when returned, freight prepaid to CORKEN, INC., 9201 North I-35 Service Road, Oklahoma City, OK. 73131.

Parts subject to wear or abuse, such as mechanical seals, blades, piston rings, valves and packing, and other parts showing signs of abuse, neglect or failure to be properly maintained are not covered by this limited warranty. Also, equipment, parts and accessories not manufactured by CORKEN but furnished with CORKEN products are not covered by this limited warranty and the purchaser must look to the original manufacturer's warranty, if any. This limited warranty is void if the CORKEN product has been altered or repaired without the consent of CORKEN.

All implied warranties, including any implied warranty of merchantability or fitness for a particular purpose, are expressly negated to the extent permitted by law and shall in no event extend beyond the expressed warrantee period.

CORKEN DISCLAIMS ANY LIABILITY FOR CONSEQUENTIAL DAMAGES DUE TO BREACH OF ANY WRITTEN OR IMPLIED WARRANTY ON CORKEN PRODUCTS. Transfer of toxic, dangerous, flammable or explosive substances using CORKEN products is at the user's risk. Experienced, trained personnel in compliance with governmental and industrial safety standards should handle such substances.

Contacting the Factory

Before you contact the factory, note the model number and serial number of your pump. The serial number directs us to a file containing all information on material specifications and test data applying to your specific pump. When ordering parts, the Corken service manual or Operations, Installation and Maintenance (IOM) manual should be consulted for the proper part numbers. ALWAYS INCLUDE THE MODEL NUMBER AND SERIAL NUMBER WHEN ORDERING PARTS.

The model and serial numbers are shown on the nameplate of the unit. Record this information for future reference.

Model No. _____

Serial No. _____

Date Purchased _____

Date Installed _____

Purchased From _____

Installed By _____

Table of Contents

APPLICABLE NOTICES FOR ATEX 2014/34/EU CONFORMITY	4
FEATURES OF THE B177 EXTERNAL AUTOMATIC BYPASS VALVE	5
INSTALLATION OF THE B177 EXTERNAL AUTOMATIC BYPASS VALVE	5
Operation of the B177 External Automatic Bypass Valve	5
APPENDICES	
A. Model Number Identification Code and Available Options	7
B. Specifications	8
C. Performance	8
D. Outline Dimensions	9
E. Parts Details	10

Applicable Notices for ATEX 2014/34/EU Conformity

Product Type:

Corken Liquid Transfer Bypass Valves

Model Covered:

B177

Intended Application:

The bypass valve models covered by this manual conform to the European Union ATEX 2014/34/EU Directive for explosive gas atmospheres and transfer of liquefied gases such as Liquefied Petroleum Gas, anhydrous ammonia, freons, etc.

Possible Misuse Warning:

The designated bypass valve models must only be installed in systems designed for its intended use, similar to the examples presented in this manual.

ATEX Classification:

Group II; Category 2; G; Temperature Class T4 – T5

These products are classified under the ATEX directive as Equipment – Group II – Category 2 – equipment is intended for use in areas where explosive atmospheres caused by gases or vapors (G) may be present. The surface Temperature Class rating is a range between T4 275°F (135°C) and T5 212°F (100°C).

Nameplate:

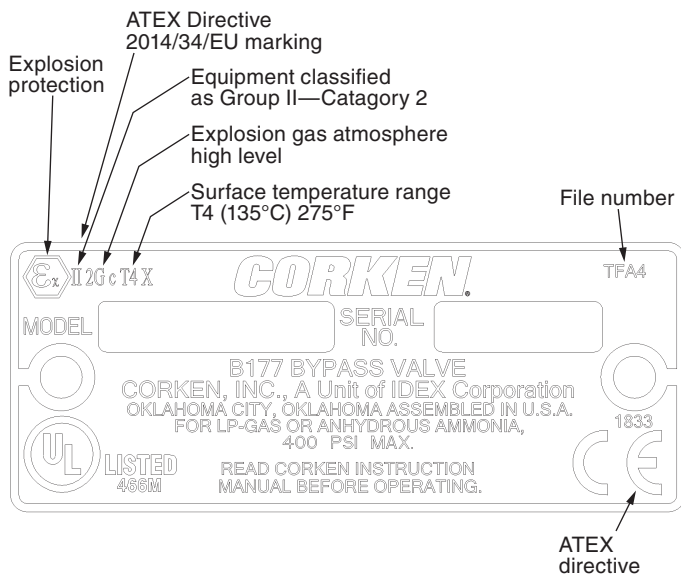

Training Instructions:

Instructions for the safe application and use of this product are provided in this manual. Read this manual completely prior to installation and use of this product. Only qualified and properly trained personnel should be allowed to install, operate, and maintain this equipment.

Mechanical Ignition Sources:

The bypass valve is installed as part of an assembly including the pump and the entire system must be grounded to prevent possible electrostatic discharge. Installation and adjustment guidelines are provided in this manual and are to be followed for the proper operation and performance of the valve.

Sound Levels:

These products are reactionary devices used in pumping systems. Sound levels are highly dependent upon the application, product being pumped, and installation. When operating in the system the valves should have a noise level no higher than 80 dBA.

Piping Forces and Moments:

Maximum Allowable Nozzle Forces and Moments

Note: Piping systems should be designed according to standard engineering practice and applicable national and local codes. NO piping induced forces or moments are recommended for Corken B177 bypass valves.

X—Horizontal (perpendicular to valve discharge port)

Y—Vertical

Z—Horizontal (parallel to valve discharge port)

$F_x = F_y = F_z = 42 \text{ lb (19 kg)}$

$M_x = M_y = M_z = 70 \text{ ft}\cdot\text{lb (10 kg}\cdot\text{m)}$

! Notice!

Corken bypass valves should only be installed in LPG & NH₃ systems that have been designed by qualified engineering personnel and operated and maintained by qualified technicians. The system must conform to all applicable local and national regulations and safety standards (specifically, LPG systems **must** conform to NFPA 58). This manual **must** be kept with the bypass valves and be reviewed **before** installing, operating or performing any maintenance work.

! Warning!

Do not attempt to open the pump or bypass valve until you have bled off the pressure. High pressure in the system can cause personal injury and/or property damage. Please note: if the system contains a meter, the differential valve will keep liquid under pressure in the pump, meter and piping even after the hose has been emptied.

Features of the B177 External Automatic Bypass Valve

The CORKEN B177 external bypass valve is designed to maintain a constant differential pressure across a sliding vane pump or any other piece of equipment requiring differential pressure control. Since horsepower is directly related to the amount of differential pressure generated by a sliding vane pump, limiting pressure limits horsepower. This is particularly important on electrically driven pumps used to load or unload product from bobtails or transports. If a valve is inadvertently closed, it can overload the motor or cause the pump to build too much pressure. To prevent this from happening, an external bypass valve is installed in the piping system.

To ensure optimum performance of the external bypass valve and the entire pumping system, follow the instructions in this manual.

Installation of the B177 External Automatic Bypass Valve

The B177 external bypass valve may be installed in either a vertical or horizontal position. Figure 1.1 illustrates how the B177 is installed as a pump differential bypass valve. The minimum size of the inlet and outlet piping should not be smaller than the opening of the external bypass valve. The outlet piping of the external bypass valve should return to the liquid or vapor section of the storage tank. **Do not connect the outlet piping of the external bypass valve to the inlet piping of the pump.**

NOTE: A balance line **must** connect the valve bonnet to the storage or supply tank. The minimum size for the balance line is indicated in the following table.

Valve Model	Minimum Balance Line Tubing Size
B177-2 B177-2.5	1/2"

Operation of the B177 External Automatic Bypass Valve

The differential pressure setting of the B177 external bypass valve is adjustable. The range of differential pressure depends on the size of the spring installed in the bypass valve. When the bypass valve ships from the CORKEN factory, a tag identifying the spring size is attached to the valve bonnet. The table below shows the part number and differential pressure range for each spring. All of the springs are interchangeable with each valve size.

Valve Model	Spring Number	Differential Pressure (PSIG)
B177-2 B177-2.5	1783	10–40
	1785	30–80
	1786	80–110
	1786-1	100–125

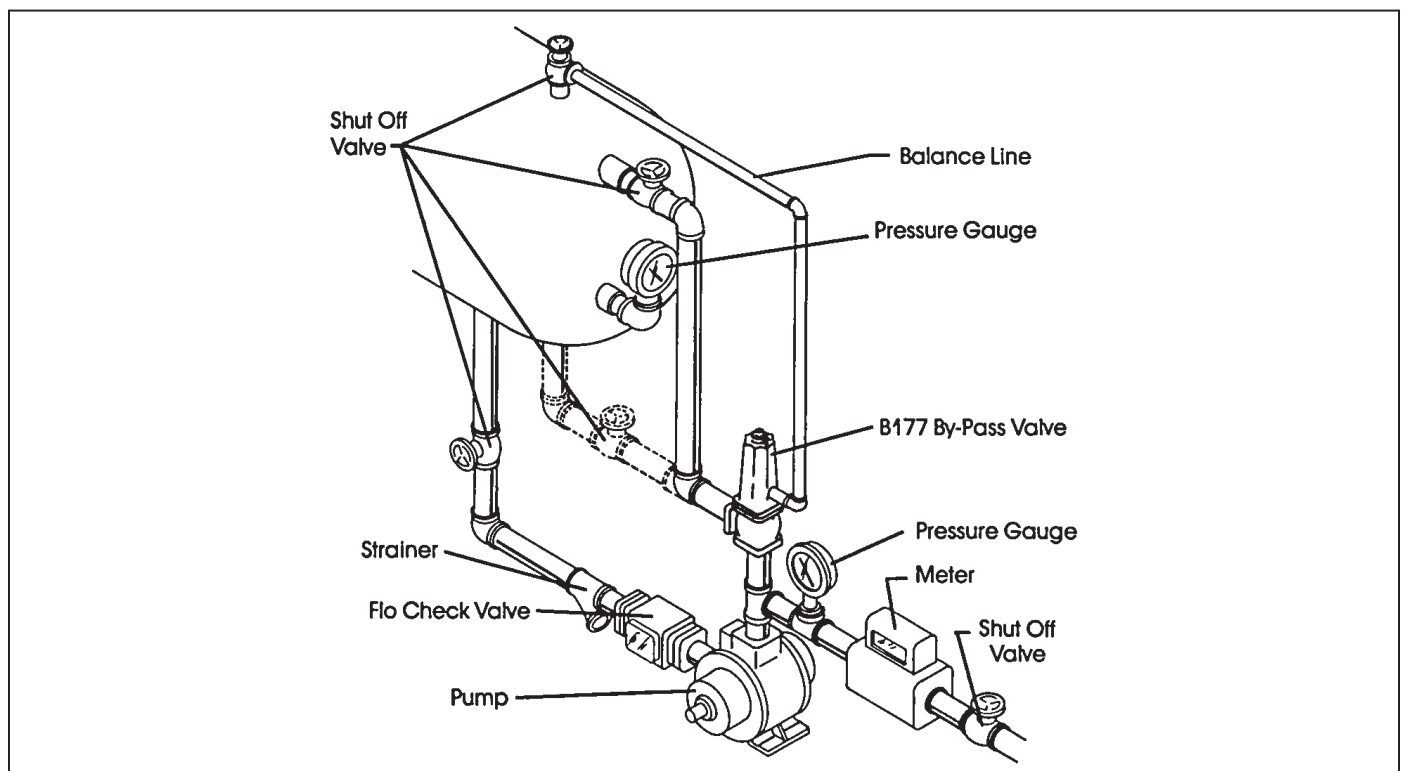

Figure 1.1: Typical installation.

Stationary pump applications equipped with an electric motor drive:

1. Install liquid-filled pressure gauges equipped with a needle valve or snubber in the following locations:
 - a. Pump discharge gauge port or inlet side of the bypass valve.
 - b. Supply tank and/or pump suction.
2. Attach an ammeter to a motor lead of the electric motor.
3. Adjust the B177 external bypass valve to the lowest pressure setting by turning the adjusting stem fully **clockwise** until the spring tension is no longer present.
4. Make sure the shut-off valves on the pump discharge line and bypass return line are in a fully open position.
5. Start the pump and circulate the liquid back to the supply tank using the discharge line.
6. Slowly close the shut-off valve located on pump discharge line so all of the liquid flows through the external bypass valve.
7. Slowly **increase** the setting of the B177 external bypass valve by turning the adjustment stem **counterclockwise** until the ammeter indicates the full-load current indicated on the motor nameplate or required differential pressure is reached. Record the pressure on the gauge mounted on the inlet side of the bypass valve.
8. If the pump has an internal relief valve, the B177 external bypass valve should be set at least 20–25 psi (1.38 to 1.72 bar) below the setting of the pump's built in relief valve. Following this guideline ensures the liquid does not recirculate through the internal relief valve and eliminates the possibility of erratic "hunting" between the two valves.
9. If possible the setting of the B177 external bypass valve should be 15 psi (1.03 bar) higher than the normal operating pressure of the piping system. An operating pressure near the external bypass valve setting may cause the liquid to recirculate unnecessarily.
10. Adjust the pressure setting of the B177 external bypass valve if necessary. It can be adjusted by turning the adjustment stem **counterclockwise to increase** pressure and **clockwise to decrease** pressure.
11. Once a satisfactory pressure adjustment has been achieved, attach the "tamper-proof" seal furnished with the external bypass valve to prevent unauthorized adjustments.

12. Open the shut-off valve located on the pump discharge line downstream of the external bypass valve and continue pumping as needed.

WARNING: Do not adjust the external bypass valve beyond the range of the spring being used.

NOTE: On Anhydrous Ammonia and LP-Gas installations, follow the guidelines provided by Underwriter's Laboratories, Inc. and NFPA Pamphlet # 58.

Notice!

1. If the external automatic bypass valve is sized and set correctly, a manual or hand operated bypass valve—if applicable—should remain in the closed position during normal operation. Keeping the manual or hand operated bypass valve closed ensures the external automatic bypass valve operates in a normal capacity.
2. Annual inspection and testing of the internal relief valve—if applicable—and the external automatic bypass valve are recommended. For testing procedures refer to the adjustment procedures listed in this manual.

Appendix A—B177 Model Number and Identification Code

Base Model	B177-2	B177-2.5
Inlet	2" NPT	2-1/2" NPT
Outlet	2" NPT	2-1/2" NPT
Maximum flow rate (gpm)	300	350
Ship weight lb (kg)	45 (20.4)	45 (20.4)

Model Number
Base X X X

Springs	10–40 psig differential range	No charge option	A
	30–80 psig differential range	No charge option	B
	80–110 psig differential range	No charge option	C
	100–125 psig differential range	No charge option	D

O-ring Material	Buna-N	Standard	A
	Neoprene ^{®1}	No charge option	B
	Viton ^{®1}	No charge option	D
	PTFE	No charge option	E

Flanges	2" NPT flanges	Standard	N/A	E
	2" Slip-on weld flanges	Charge option	N/A	F
	2.5" NPT flanges	N/A	Standard	J
	2.5" Slip-on weld flanges	N/A	Charge option	K

¹Registered trademark of the DuPont company.

Appendix B—Specifications

Equipment Type

Low pressure build-up bypass valve 30 to 100 gpm
(9.1 to 79.5 m³/hr)

Applications

Used in bulk plant loading and unloading pumps.

Features & Benefits

Can also be used as a differential back-pressure valve to assure adequate pressure on meters.

Operating Specifications

Inlet	2", 2-1/2"
Outlet	2", 2-1/2"
Differential pressure range psi (bar)	10–125 (0.69–8.60)
Maximum working pressure	400 psi (27.6 bar)

Material Specifications

Part	Standard Material	Optional Material
Valve body	Ductile iron: ASTM 536, 60-40-18	
Valve bonnet	Ductile iron: ASTM 536, 60-40-18	
O-rings	Buna-N	Neoprene ^{®1} , Viton ^{®1} , PTFE
Spring	Music wire/chrome silicon	
Flanges	Ductile iron: ASTM 536, 65-45-12 (NPT)	Plate steel: ASTM A516 (weld flange)
Plunger	ASTM A48 gray iron class 20	
Plunger seat	PTFE	
Plunger bolt	3/8" – 16 x 3/4" button head capscrew with hexagon socket—steel	
Plunger nut	Steel	
Spring seat	ASTM A48 gray iron class 30	
Spring platform	ASTM A108 GR 1200 steel	
Stem seal	Buna-N	PTFE
Stem seal washer	Steel	
Retainer ring	Steel	
Seat retainer plate	Steel	

¹Registered trademark of the DuPont company.

Appendix C—Model B177 Performance Curves

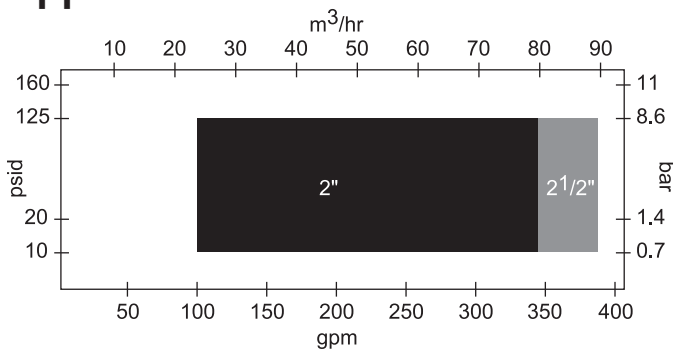

Appendix D—Outline Dimensions for Model B177

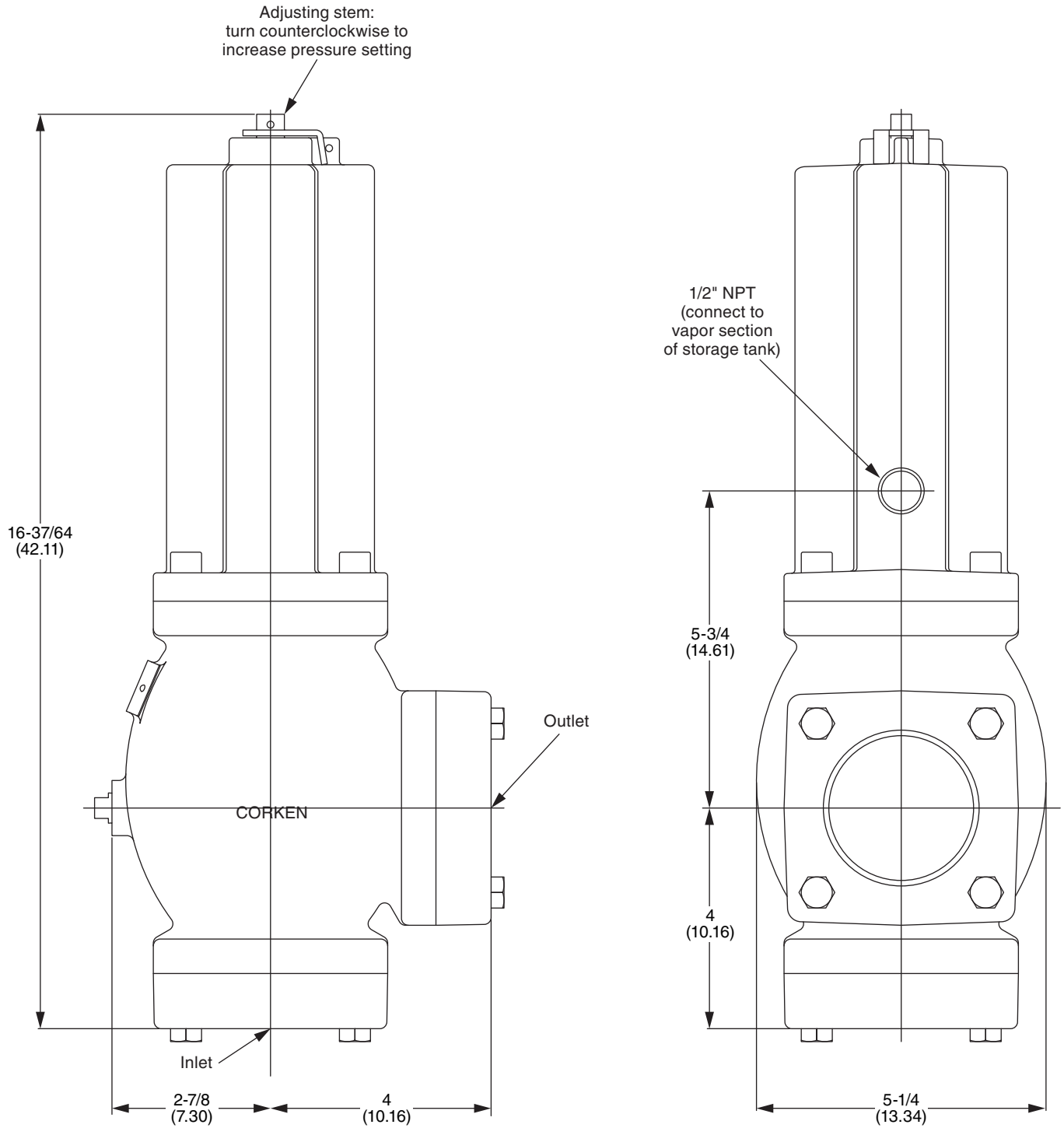

All dimensions are in inches (centimeters).

Appendix E—Parts Details for Models B177-2 and B177-2.5

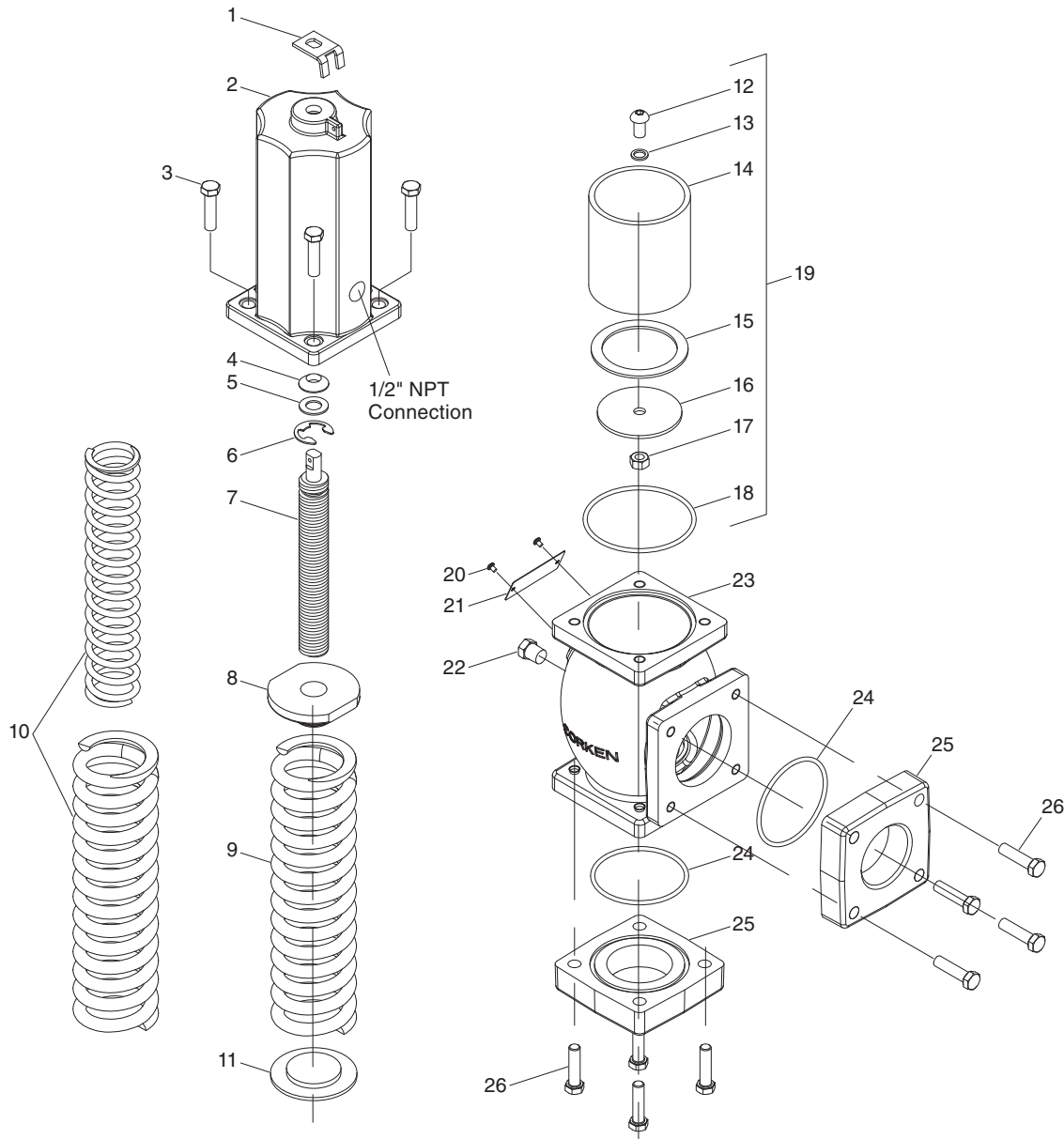

O-ring Code	
A	Buna-N
B	Neoprene ^{®a}
D	Viton ^{®a}
E	PTFE

Ref. No.	Part No.	Description	Qty
1	2080	Lock	1
2	1698	Bonnet	1
3	7002-037NC125A	Socket head - 3/8-16 X 1-1/4", grade 8	4
4	1887	Stem seal	1
5	1789	Stem washer	1
6	5133-87	Retainer ring	1
7	1702	Adjusting stem	1
8	1701	Spring seat	1
9.	1783	Spring (10 to 40 psi)	1
	1785	Spring (30 to 80 psi)	1
	1786	Spring (80 to 110 psi)	1
10.	1786-1	Spring (100 to 125 psi)	1
11.	1780	Spring platform	1
12.	1872	Plunger bolt	1
13.	2732	Center headbolt gasket - steel	1
14.	1699	Plunger	1

Ref. No.	Part No.	Description	Qty
15.	1700	Seat - PTFE	1
16.	1703	Retainer plate	1
17.	1873	Locknut	1
18.	2-238_1	O-ring	1
19.	1699-X	Plunger assembly	1
20.	7012-006SF019E	Pan head Phillip 6-32 X3/16"	2
21.	1833	Nameplate	1
22.	3442	Pipe plug - 1/4 NPT	1
23.	1697	Body - B177-2 & B177-2.5	1
24.	2-234_	O-ring - Buna N	2
25.	7001-037NC150A	Hex head - 3/8-16 X 1-1/2", gr L7	8
26.	1172-2	Flange - 2" NPT	2
	1172-2S	Flange - 2" Weld	2
	1172-2.5	Flange - 2.5" NPT	2
	1172-2.5S	Flange - 2.5" Weld	2

^aRegistered trademark of the DuPont company.

^b_ denotes O-ring code. See chart above.

Solutions beyond products...

CORKEN®

CORKEN, INC. • A Unit of IDEX Corporation

9201 North I-35 Service Road, Oklahoma City, OK. 73131

Phone (405) 946-5576 • Fax (405) 948-7343

Visit our website at <http://www.corken.com>

or e-mail us at cocsalesdept@idexcorp.com

