

# Type C831 Series Internal Valves Instruction Manual



## WARNING

Failure to follow these instructions or to properly install and maintain this equipment could result in an explosion, fire and/or chemical contamination causing property damage and personal injury or death.

Fisher equipment must be installed, operated, and maintained in accordance with federal, state, and local codes and Fisher instructions.

Only personnel trained in the proper procedures, codes, standards, and regulations of the applicable industrial service should install and service this equipment.

The internal valve must be closed except during product transfer. A line break downstream of a pump may not actuate the excess flow valve. If any break occurs in the system or if the excess flow valve closes, the system should be shut down immediately.



Figure 1. C831 Series

## Introduction

### Scope of Manual

This manual covers instructions for the C831 Series 2" and 3" 300# Raised Face Flange internal valves.

These valves are serialized for the service specified with the order. The valves can be used on other compressed gases, but the user should check with the factory to make sure the valve materials are suitable for the intended service.

### Description

The valves are typically used on the inlets and outlets of transport trucks and on large stationary storage tanks.

### Specifications

Specifications for C831 Series internal valves are in Table 1.

**DOT Internal Self-Closing Stop Valve Requirement** — U.S. Department of Transportation (DOT) regulations 49CFR§178.337-8(a)(4) require each liquid or vapor discharge outlet on cargo tanks (except for cargo tanks used to transport chlorine, carbon dioxide, refrigerated liquid, and certain cargo tanks certified prior to January 1, 1995) to be fitted with an internal self-closing stop valve. Fisher's "C" series internal valves comply with the internal self-closing stop valve requirement under the DOT regulations.

## Installation

### NOTE:

**Installer must furnish 8 stud bolts, 8 flange nuts, and spiral wound gaskets as these parts are not supplied with the internal valves.**

Coat both sides of the spiral wound gaskets with Dow Corning #111 silicone grease or equivalent. An appropriately sized tank flange, see figure 2, must be installed in



# Type C831 Series Internal Valves

Table 1. Specifications

<b>BODY SIZE AND END CONNECTION STYLE</b>	<b>Inlet:</b> 2 or 3-inch 300# ANSI R.F. Flange <b>Outlet:</b> 2 or 3-inch 300# ANSI R.F. Flange	<b>MATERIALS OF CONSTRUCTION</b>	Stainless Steel: Lever, Cam, Disc Holder, Springs, Hexagon Head Cap Screws, Cotter Pin, Stub Shaft, Stem, Washers, Drive Screw, Plug Holder, Stop Tube, Body, Gland, Web, Pins, Screws, Bolts, Nut Washer, Spring Seat, Disc Retainer, Disc Holder, and Retainer  Plated Steel: Nameplate, Drive Pin  Polyurethane: Rod Wiper  PTFE or Filled PTFE: Gland Packing, Liner Brushing, Washer, Wear Plug  Nitrile (Standard Construction): Disc and O-Rings  Other Disc and O-Ring Trim Material Available from Factory: TFE, Neoprene, Ethylene Propylene, Viton, and Kalrez
<b>NUMBER OF OUTLETS</b>	<b>C831:</b> 2 (side & straight through)		
<b>MAXIMUM ALLOWABLE INLET PRESSURE</b>	500 psig (34.5 bar) WOG		
<b>EXCESS FLOW SPRINGS</b>	<b>2-Inch Sizes:</b> 85 (322), 110 (416) & 160 (605) gpm (lpm) water <b>3-Inch Sizes:</b> 110 (416), 145 (549), 175 (662), 270 (1022), & 345 (1306) gpm (lpm) water		
<b>MATERIAL TEMPERATURE CAPABILITIES</b>	-20° to 150° F (-28,9 to 65,6° C)		
<b>APPROXIMATE WEIGHT</b>	<b>2-Inch C831:</b> 20 lbs. (9.07 kg) <b>3-Inch C831:</b> 32 lbs. (14.5 kg)		

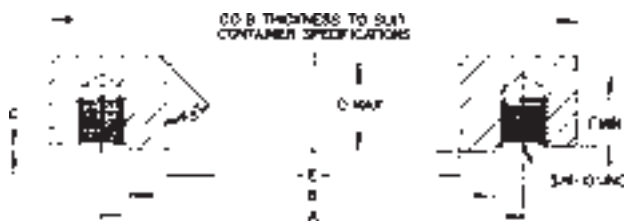

Figure 2

TANK CONNECTION FLANGES - DIMENSIONS ARE IN INCHES (mm)								
300 LB. ANSI RF FLANGE	A-BOLTING			B RF	C RF	D	E	MATING FLANGE O.D.
	DBC	NO.	Size					
2-inch (50.8)	5.0 (127)	8	5/8 (15.9)	3.62 (92)	.06 (1.5)	1.45 (36.8)	2.46 (62.5)	6.50 (165)
3-inch (76.2)	6.62 (168)	8	3/4 (19)	5.75 (146)	.06 (1.5)	1.50 (38)	4.62 (117)	8.25 (210)

the tank. The internal valve can then be installed in the tank and outlet piping attached to the internal valve.

Keep piping from the valve outlet to the pump full size and as short as possible with a minimum number of bends. Reduction in pipe size to suit smaller pump inlets should be made as close to the pump as possible using forged reducers (swage nipples) or venturi tapers rather than bushings. This assures minimum flow resistance and efficient pump operation.

The valves have a break off section below the inlet flange which is intended to permit the lower valve body to shear off in an accident, leaving the valve seat in the tank. **The break off section is designed for container installations and will probably not provide shear protection if the valve is installed in a pipeline.**

A hydrostatic relief valve does not need to be installed adjacent to the valve since the internal valve relieves excessive line pressure into the tank.

## Selectively Filling Manifolded Tanks

Fisher internal valves provide positive shut-off only in one direction, from out of the tank to downstream of the valve. The internal valves are designed to allow gas to flow into a tank when the downstream line pressure exceeds tank pressure. If you want to selectively fill one or more of the other tanks in a tank manifold system, you must place a positive shut-off valve downstream of the internal valve, otherwise, all tanks will be filled at the same time and at about the same rate.

## Actuators

The remote operating control system for the valve is extremely important, and it must be installed to conform with the applicable codes. DOT MC331, for example, most generally applies for trucks.

Fisher offers both cable controls and air cylinder systems to operate the C831 series internal valves. It may also be possible to use cable controls from other manufacturers or to fabricate a linkage mechanism.

Any control system requires thermal protection (fuse links) at the valve, at the remote control point and, if necessary, near the hose connections. The instruction manuals for Fisher Controls actuator systems show how to install the fuse links.

Installation instructions on Fisher P650, P163A, and P164A cable controls, are in Form MCK-1083. Air cylinder actuator installation is covered in Form MCK-1137. Type P340 latch/remote release instructions are on Form MCK-2048.

The operating linkage must allow the operating lever to move from the fully closed position to within 2° of the fully open position. The linkage should not apply strong force to the lever past the fully open position or the valve could be damaged.

### CAUTION

The internal valve's closing spring is not designed to overcome drag in the control linkage in order to close the valve. Depending upon the control system used, an external spring (such as Fisher drawing number 1K4434) or positive closing linkage may be needed. Be sure the control system is installed to prevent binding that could cause the valve to stick in the open position.

## Excess Flow Operation

The internal valve contains an excess flow function, or "integral excess flow valve", that will close when the flow exceeds the flow rating established by Fisher. Fisher's integral excess flow valve installed on a bobtail truck or transport can provide protection against the discharge of hazardous materials during an unloading operation of a bobtail truck or transport in the event that a pump or piping attached directly to the internal valve is sheared off before the first valve, pump, or fitting downstream of the internal valve, provided that the cargo tank pressure produces a flow rate greater than the valve's excess flow rating.

Likewise, if the internal valve is installed on a stationary tank or in the related downstream piping system, the integral excess flow valve can provide protection against an unintentional release of hazardous materials in the event that a pump or piping attached directly to the internal valve is sheared off before the first valve, pump, or fitting downstream of the internal valve, provided that the flow of product through the internal valve reaches the rated flow specified by Fisher.

### EXPLOSION HAZARD

**Restrictions incorporated in the discharge system of a bobtail truck or transport or of a stationary tank (due to pumps, pipe and hose length and dimensions, branching, elbows, reductions in pipe diameter, or a number of other in-line valves or fittings), low operating pressure as a result of ambient temperature, or a partially closed valve downstream from the integral excess flow valve, can restrict the rate of flow**

**through the internal valve below the level necessary to actuate the integral excess flow valve. Therefore, DO NOT USE the excess flow function of the internal valve for the purpose of providing protection against the discharge of hazardous materials in the event of a rupture of hose or piping at a point in the discharge system downstream from the first valve, pump, or fitting downstream of the internal valve.**

The internal valve is designed with an internal bleed feature for equalization of pressure. After the integral excess flow valve closes, the leakage through the bleed must be controlled or a hazard can be created. For this reason the operator must be familiar with the closure controls for the internal valve and must close the internal valve immediately after the integral excess flow valve closes.

**Failure to follow this warning could result in serious personal injury or property damage from a fire or explosion.**

**DOT Passive Shutdown Equipment Requirement** — DOT regulations 49CFR§173.315(n)(2) require certain cargo tanks transporting propane, anhydrous ammonia and other liquefied compressed gases to be equipped with passive emergency discharge control equipment that will automatically shut off the flow of product without human intervention within 20 seconds of an unintentional release caused by complete separation of a delivery hose. The design for each passive shut-down system must be certified by a Design Certifying Engineer (DCE) and all components of the discharge system that are integral to the design must be included in the DCE certification. The DCE certification must consider any specifications of the original component manufacturer.

In the case of downstream ruptures in hose or piping, a variety of operating conditions routinely encountered during an unloading operation restrict the rate of flow through the integral excess flow valve and make such a valve unsuitable to serve as the means of passive shut-down required under 49CFR§173.315(n)(2). Such variables include restrictions incorporated in the discharge system (due to pumps, pipe and hose length and dimensions, branching, elbows, reductions in pipe diameter, or a number of other in-line valves or fittings), low operating pressure as a result of ambient temperature, or a partially closed valve downstream from the excess flow valve. Due to the variety of conditions, in the case of a hose separation, that can restrict the rate of flow below the level necessary to activate the excess flow valve, the integral excess flow function of Fisher's "C" series internal valves or "F" series excess flow valves cannot be used to satisfy

# Type C831 Series Internal Valves

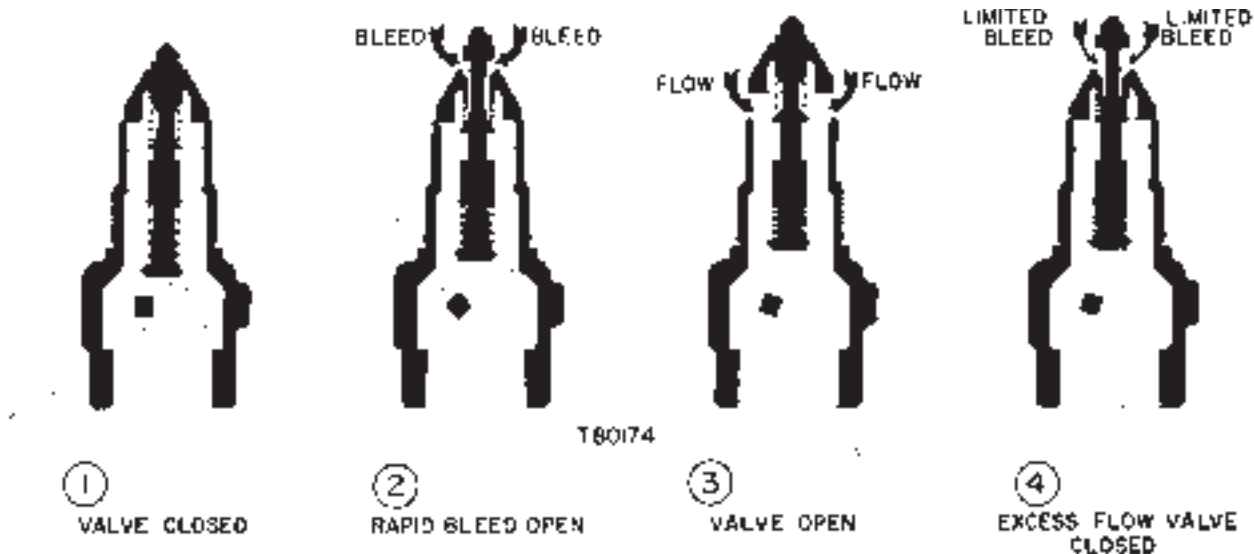

Figure 3. Operational Schematic

the passive shut-down equipment requirement under/in 49CFR§173.315(n)(2). Also, a Design Certifying Engineer cannot include the integral excess flow valve of a Fisher “C” series internal valve or “F” series excess flow valve as a component of the discharge system in any DCE certification under 49CFR§173.315(n)(2).

## EXPLOSION HAZARD

**DO NOT USE** the excess flow function incorporated into Fisher “C” series internal valves or “F” series excess flow valves to satisfy the passive shutdown equipment requirement in 49CFR§173.315(n)(2). **DO NOT include** the excess flow function incorporated into Fisher “C” series internal valves or “F” series excess flow valves in a DCE certification under 49CFR§173.315(n)(2). The cargo tank manufacturer must install some other equipment that satisfies the requirement for passive shutdown capability under 49CFR§173.315(n)(2).

Failure to follow this warning could result in serious personal injury or property damage from a fire or explosion in the event of an unintentional release of product during an unloading operation.

## Operation

Since the C831 series will not open unless the downstream pressure can build-up to equal the inlet pressure, an operating sequence that assures equalization is important.

Follow these points:

1. C831s on bobtails and transports should never be open when the truck is in motion. If the control system is not interlocked to prevent this, the operator is responsible to see that the valves are closed.
2. Always open the internal valve before opening any other valves in the line or starting the pump.
3. Move the lever to the half-open position (figure 3, view #2) to equalize pressure. When the main poppet clicks open, move the operating lever fully open.
4. Open other line valves slowly to avoid sudden surges which could slug the excess flow valve shut.
5. If the excess flow valve does close, stop the pump and close the nearest downstream valve. Move the internal valve’s operating lever back to the rapid equalizing position and wait for the valve to click open. Then move the operating lever fully open and slowly open the downstream valve.
6. All valves should be completely open when pumping. (Throttling type valves could prevent the excess flow valve from closing when required.)
7. The operator must always be aware of where the remote closure controls are located and know how to operate the controls if an emergency requires valve closure. When pumping is finished, make a habit of closing the internal valve from the remote closure point, thus checking to see that the control actually is capable of closing the valve.
8. The valve should be open when backfilling through the valve to fill the tank.

## Troubleshooting

**Internal Valve Will Not Open** – This could be due to leakage downstream, engaging the pump too soon or from

excessive wear in the internal valve. If excessive volume is in the downstream system, a longer time is required to equalize the pressures (tank and downstream) before the pump can be engaged. To determine if the valve pilot seat is opening, install a gauge downstream of the valve, operate the valve actuator; if pressure does not build up to the tank pressure, the valve pilot seat is not open. This test should be done with pump off. If the pilot is not opening, it may be plugged with dirt or some internal part may be broken. If by operating the lever manually it can be rotated past the fully open position, there is something wrong internally and the valve must be disassembled.

**Premature Valve Closure** – This can be caused from engaging the pump too soon, by an underrated excess flow valve spring, or by an improperly connected internal valve operating lever which does not fully open the valve. The trouble could also be from a valve that has its inlet port obstructed or from sudden line surges. In order to check the valve opening travel, operate the lever manually to the full travel, wait until valve opens (usually about 15 seconds), then engage the pump. If the excess flow closes, the points mentioned above should be investigated.

**Internal Valve Will Not Close** – The stub shaft could be binding or the stem could be bent in the valve. Before disassembling the valve, check the actuator mechanism to see that it operates freely by disconnecting it from the valve lever and cycling it several times. Also, operate the valve lever manually. If it sticks in the open position, the packing and bushings should be replaced. This should free the operating mechanism if the valve has not been damaged internally. Refer to the “Maintenance” section.

**Low Flow Capacity** – This could be caused by too small an internal valve, too small or long downstream piping, plugged screens, some other restriction in the downstream system, or by the bypass valve sticking in the open position. The bypass valve could also be set too low and be opening prematurely.

## Principle of Operation

Refer to the schematic drawing, figure 3. In view #1, the valve is held closed by both tank pressure and the valve’s closing spring. There is no leakage past the resilient seats in the poppet to the valve outlet.

The valve is opened by moving the operating lever to approximately mid-point in its 70° travel (view #2). This allows the cam to place the rapid equalization portion of the valve stem in the pilot opening, permitting a larger amount of product to bleed downstream than if the operating lever were moved to the full open position.

When tank and downstream pressure are nearly equal after a few seconds, the excess flow spring pushes open the main poppet (view #3) and the operating lever can be

moved to the full open position.

If tank pressure is greater than the valve’s outlet pressure, the main poppet will remain in the closed position. If valve outlet piping is closed off by other valves, however, product bleeding through the pilot will increase until it nearly equals tank pressure and the main poppet opens.

### Note

**The main poppet will not open if valve outlet piping is not closed off so that the outlet pressure can approach tank pressure.**

Once the main poppet opens, a flow greater than the valve’s excess flow spring rating or a sufficient surge in flow forces the main poppet closed against the excess flow spring (view #4). The pilot valve allows a small amount of product to bleed, but much less than view #2 where the rapid equalization portion of the stem is placed in the pilot opening. When the operating lever is moved to the closed position, the valve closes completely and seals tightly (view #1).

## Maintenance



**Do not use these internal valves if they leak, fail to work properly or have been damaged or have missing parts. Prompt repairs should be made by a properly trained serviceman. Continued use without repair can create a hazardous or injurious situation.**

A simple preventative maintenance program for the valve and its controls will eliminate a lot of potential problems.

**Fisher recommends these steps be conducted once a month. Also refer to the Department of Transportation (DOT) CFR 49 Sections 180.416 and 180 Appendix A & B which specify monthly maintenance and inspections tests for cargo tank service internal valves and their actuation controls.**

1. Inspect the operating lever to see that it operates freely and that there is no leakage around the retainer nut. If there is sticking or leakage, replace the packing and bushings. Refer to Replacing Packing.
2. Check for tight closure of the seat discs. Any detected leakage, which is normally caused by disc wear or dirt, scale or debris embedded in the disc, requires that the internal valve be removed from service and repaired. Repair most often requires the replacement of valve discs. To check for leakage:
  - a. Close the internal valve and exhaust downstream

# Type C831 Series Internal Valves

pressure. Close the first valve downstream from the internal valve, and note any pressure buildup, using a pressure gauge, between the closed valve and the internal valve. If piping is cold allow it to warm to ambient temperature.

b. Refer to CFR 49 Section 180 Appendix B for Meter Creep Test Methods.

3. All operating controls should be inspected and cleaned and oiled. The controls should be checked to see that they fully open—but not over-travel—the internal valve operating lever and operate freely to close the valve.
4. Standard construction internal valves must be removed if the container is to be steam cleaned. Heat can damage the valve's seats and seals.
5. Standard construction internal valves are not designed for water service. Immediately after a container is hydrostatically tested, remove all water and allow the container to thoroughly dry out.

## Disassembly



### WARNING

**Tank pressure must be released before removing the valve from the container. Failure to do so could result in personal injury.**

Numbers in parenthesis refer to key numbers in figure 4.

## To Replace Packing

1. The packing (keys 15F, G, & H) can be replaced with product in the tank by closing the operating lever (key 18) and blowing down the downstream pressure in the system.
2. Remove the three cap screws (key 17) holding the bonnet assembly to the body.

3. Rotate the entire bonnet assembly slightly to remove it from the body.
4. Unscrew the cap screw (key 15R) from the stub shaft (key 15J), and remove the operating lever by taking out the cotter pin (key 19).
5. Unscrew the retaining nut (key 15M) from the bonnet. Pushing on the stub shaft (key 15J) will expose the bonnet parts including the packing.
6. Besides the packing, the liner bushings (keys 15B & 15K) should be replaced.
7. Reassemble in reverse order. Replace cap screw (key 15R) using 30 to 35 inch-pounds torque.
8. Make sure the operating lever can move freely after the new parts are installed. Conduct a leak test under pressure with a soap solution.

## To Replace Seat Discs

1. Remove the valve from the tank.
2. Remove the cotter pin (key 14) and unscrew the hex nut (key 13).
3. Remove both disc holders (keys 6 & 12) from the stem (key 2).
4. Unscrew the three screws (key 9) holding the disc retainer (key 8) to replace the main seat disc.
5. Examine both seat discs (keys 7 & 11) and replace if necessary.
6. If the excess flow spring (key 3) is changed, replace the nameplate or stamp the body with the new type number.
7. Always replace the sealing washer (key 23).
8. Reassemble in reverse order using 15 to 20 foot-pounds torque to install the disc retainer (key 8). Apply Loctite No. 242 or equivalent on the stem threads before installing the hex nut (key 13).

## Parts Ordering

When corresponding about this equipment, always reference the equipment type number found on the nameplate.

A replacement Parts List is available for the valves. When ordering replacement parts, reference the complete 11-character part number for each needed part.

## Parts List

### Type C831 Series

Key	Description
1	Body
2	Stem Assembly
3	Excess Flow Spring
4	Spring Seat
5	Shutoff Spring
6	Disc Holder
7*	Lower Disc
8	Disc Retainer
9	Screw (3 req'd)
10	Disc Retainer
11*	Bleed Disc
12	Disc Holder
13	Hex Nut
14	Cotter Pin
15A	Bonnet
15B*	Liner Bushing
15C	Washer
15D	Spring
15E	Washer (2 req'd)
15F*	Male Packing Adaptor
15G*	Packing (3 req'd)
15H*	Female Packing Adaptor
15J	Stub Shaft
15K*	Liner Bushing
15L	Rod Wiper
15M	Bonnet
15P	Cam
15R	Cap Screw
15S	Washer
15T	Packing Ring
16*	O-Ring
17	Cap Screw (3 req'd)
18	Operating Lever
19	Cotter Pin (not shown)
20	Nameplate (not shown)
21	Drive Screw (2 req'd) (not shown)
23*	Washer
30	Fusible Link (Not shown)
33	Travel Stop
34	Washer
35	Bushing
36	Guide
51	Lube 9
55	Gasket

\* Recommended spare part

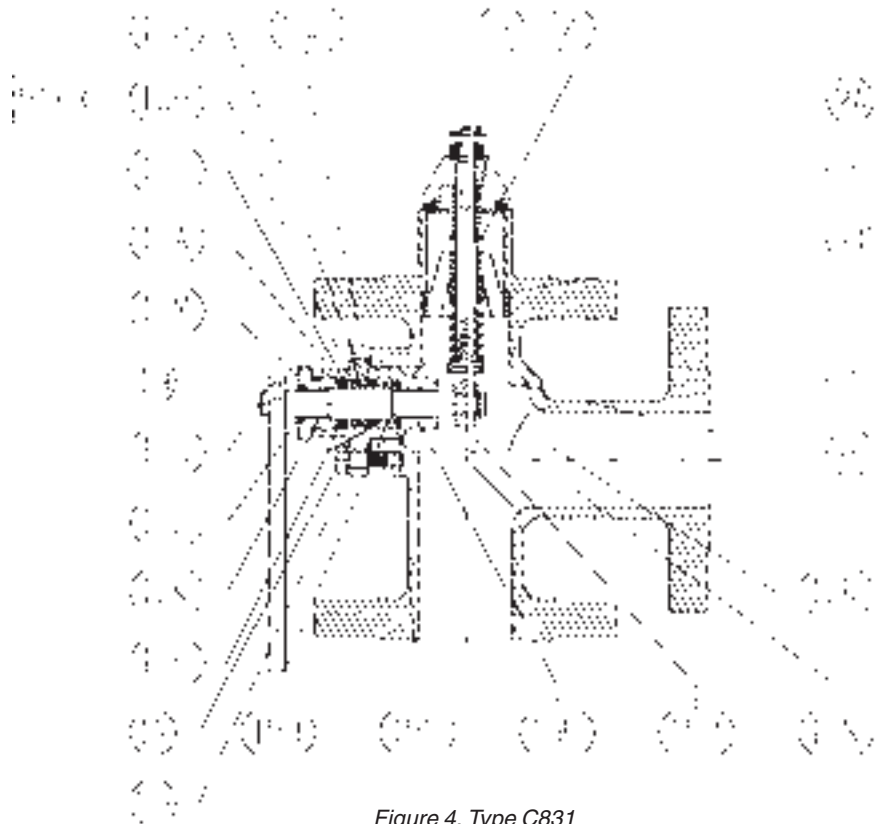
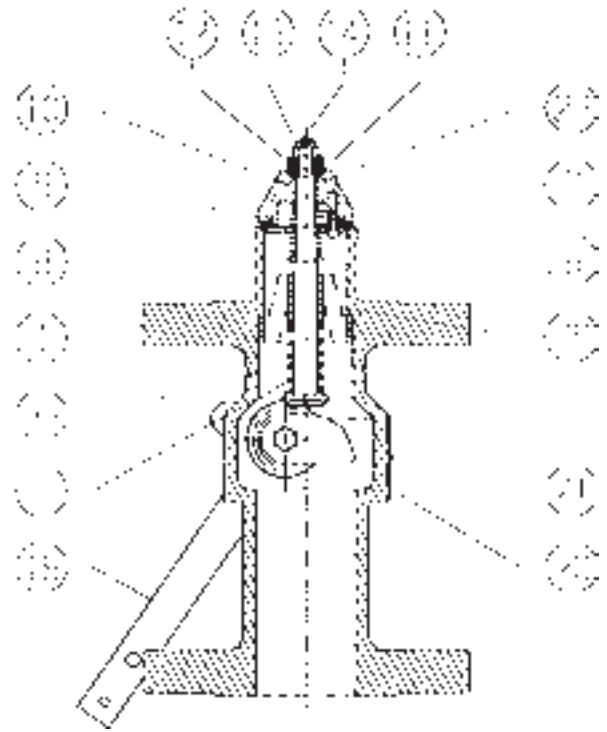
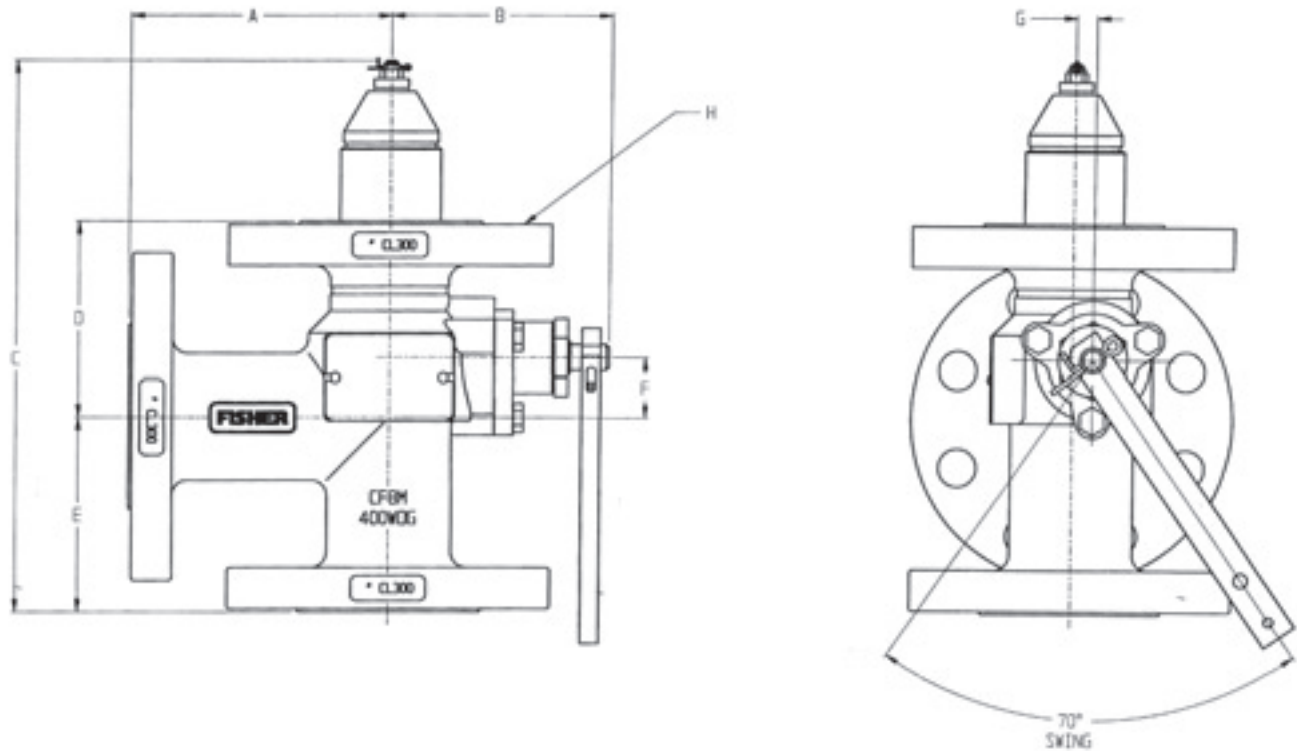

Figure 4. Type C831

# Type C831 Series Internal Valves



Flanged Valves - Dimensions Are In Inches (Millimeters)								
TYPE NUMBER	A	B	C	D	E	F	G	H
C831-16	5.25 (133)	4.41 (112)	10.94 (278)	3.88 (98)	3.88 (98)	1.18 (30)	.42 (11)	2 in. CL 300 RF
C831-24	6.75 (171)	5.13 (130)	12.50 (316)	4.63 (117)	4.63 (117)	1.38 (35)	.42 (11)	3 in. CL 300 RF

The contents of this publication are presented for informational purposes only, and while every effort has been made to ensure their accuracy, they are not to be construed as warranties or guarantees, expressed or implied, regarding the products or services described herein or their use or applicability. We reserve the right to modify or improve the designs or specifications of such products at any time without notice.

**Emerson Process Management**

**Fisher Controls International, LLC.**  
 P.O. Box 8004  
 McKinney, Texas 75070, USA  
 Telephone: 1 (800) 432-8711  
 Telephone: 1 (972) 542-5512

[www.FISHERregulators.com/lp](http://www.FISHERregulators.com/lp)

