

Types C402, C421 & C427 in 2 and 3-Inch NPT Bodies

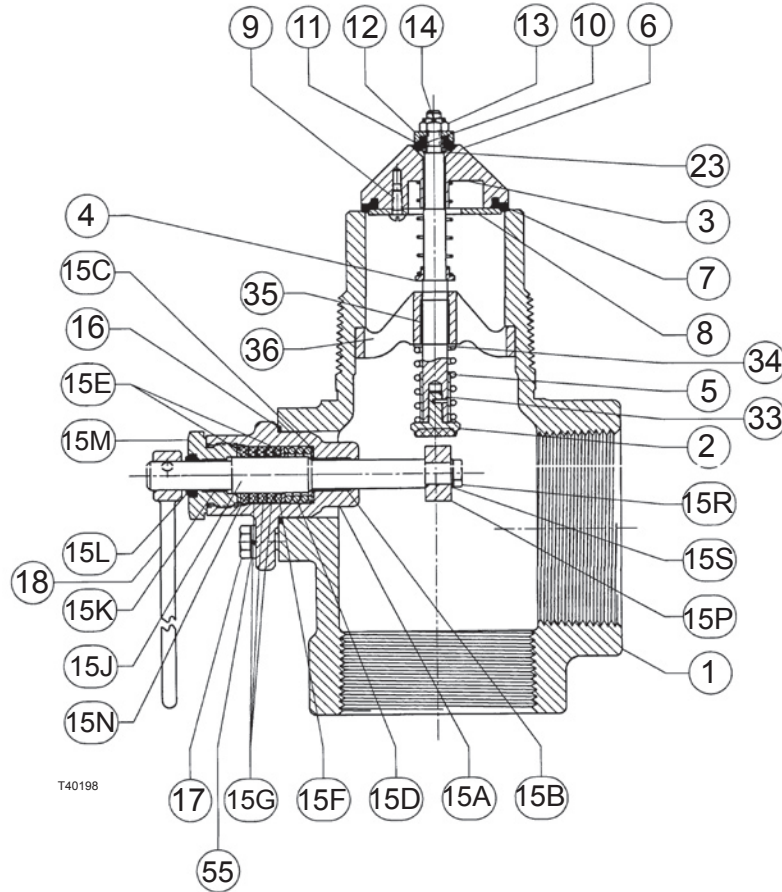

Figure 1. Type C421

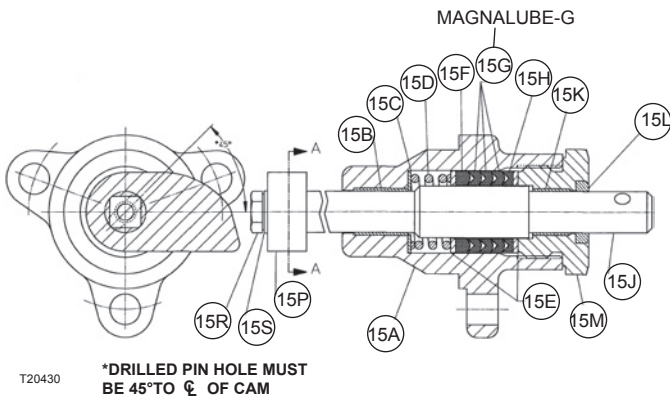

Figure 2. 2 and 3-Inch NPT Packing Gland Parts

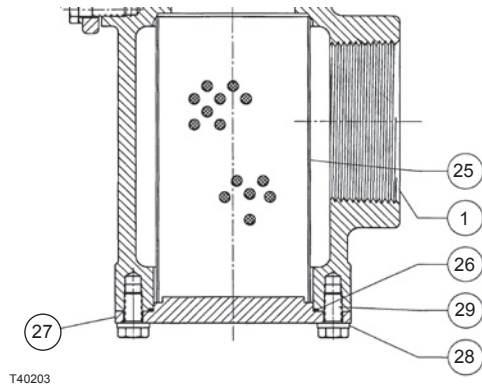

Figure 3. Type C402 Strainer Parts



C400 Series Internal Valve Parts Sheet

Replacement Parts Sheet
MCK 1114
May 2005

Parts List

Gland and Packing Assembly--Includes All Key Number 15 Parts

Completely Assembled

2-Inch NPT Valves	T20377000A2
3-Inch NPT Valves	T20430000A2

Replacement Parts Kit

Includes Key Numbers 7, 11, 14, 15B, 15F, 15G, 15H, 15K, 16, 19, 23, 26, 35

2-Inch NPT Valves	RC40016T012
3-Inch NPT Valves	RC40024T012

Key	Description	Part Number
1	Body	
	2-Inch Ductile Iron Type C421-16	T40195T0012
	3-Inch Ductile Iron Type C421-24	T80119T0012
	2-Inch Steel Type C402-16	T8011122012
	3-Inch Steel Type C402-24	T8012122012
	2-Inch Ductile Iron Type C427-16	T40132T0012
	3-Inch Ductile Iron Type C427-24	T80089T0012
2	Stem Assembly	
	2-Inch NPT Size	T11878000A2
	3-Inch NPT Size	T11887000A2
2A	Stem	
	2-Inch NPT Size	T1187935032
	3-Inch NPT Size	T1177235032
2B	Follower Assembly	T11880000A2
	Plug Holder	T1187135132
	Wear Plug	T1187201012
2C	Groove Pin	1J1560T0012
3	Excess Flow Spring	
	Closing Flow -- GPM Propane	Half Coupling Full Coupling
	2-Inch NPT Size (Red)	100 60 T1188637022
	(Yellow)	150 90 T1153537022
	(Pink)	250 130 T1200537022
	3-Inch NPT Size (Yellow)	150 100 T1192537022
	(Orange)	200 125 T1192437022
	(Pink)	250 165 T1215237022
	(Black)	400 235 T1177337022
	(Cadmium)	500 325 T1226237022
4	Spring Seat	T1153624102
5	Closing Spring	T1153737022
6	Disc Holder	
	2-Inch NPT Size	T20376T0012
	3-Inch NPT Size	T2042924102
7*	Main Disc	
	2-Inch NPT Size	T1154003202
	3-Inch NPT Size	T1177403032
8	Disc Retainer	
	2-Inch NPT Size	T1154125072
	3-Inch NPT Size	T1177525072

* Recommended Spare Part

Key	Description	Part Number
9	Screw (3 required)	1A954828992
10	Disc Retainer	T1154224102
11*	Bleed Disc	T11543T0012
12	Disc Holder	T1154424102
13	Nut	GE04678T012
14	Cotter Pin	T1241338992
15	Gland Assembly	
	2-Inch NPT Size	T20377000A2
	3-Inch NPT Size	T20430000A2
15A	Gland	T2038022012
15B	Liner Bushing	T1154506992
15C	Washer	T1154625072
15D	Spring	T1154737022
15E	Washer (2 required)	T1154825072
15F*	Male Adaptor	T1154901012
15G*	Packing Ring (3 required)	T1155001012
15H*	Female Adaptor	1H941601012
15J	Stub Shaft	
	2-Inch NPT Size	T2037835072
	3-Inch NPT Size	T2043135072
15K*	Liner Bushing	T1155106992
15L	Rod Wiper	T1155206992
15M	Bonnet	T1155324102
15P	Cam	T1155521992
15R	Cap Screw	1B848024052
15S	Washer	1C225628982
16*	O-Ring	T1155706562
17	Cap Screw (3 required)	T12499T0012
18	Lever	T1155919312
19*	Cotter Pin (Stub Shaft to Lever— Not Shown)	1H837128982
20	Nameplate (Not Shown)	Not Orderable
21	Drive Screw (2 required) (Not Shown)	1A368228982
22	Pipe Plug (Not Shown)	T13718T0012
23*	Washer	T1188228982
25	Strainer	
	2-Inch NPT Size C402-16	T1205538992
	3-Inch NPT Size C402-24	T1205638992
26*	O-Ring	
	2-Inch NPT Size C402-16	T1205006562
	3-Inch NPT Size C402-24	T1205106562
27	Bottom Flange	
	2-Inch NPT Size C402-16	T1205424332
	3-Inch NPT Size C402-24	T2047924332
28	Lockwasher (8 required)	T1022628982
29	Cap Screw (8 required)	T1206335452
30	Fusible Link	1J157443992
33	Travel Stop	T1240838072
34	Washer	T1221236152
35	Bushing	T1221306992
36	Guide	
	2-Inch NPT Size	T12918T0012
	3-Inch NPT Size	T12511T0012
53	Instruction Manual	D450022T012
55	Lock Washer (3 required)	1C2257K0012

Fisher and Fisher Regulators are marks owned by Fisher Controls International, LLC. The Emerson logo is a trademark and service mark of Emerson Electric Co. All other marks are the property of their respective owners.

The contents of this publication are presented for informational purposes only, and while every effort has been made to ensure their accuracy, they are not to be construed as warranties or guarantees, expressed or implied, regarding the products or services described herein or their use or applicability. We reserve the right to modify or improve the designs or specifications of such products at any time without notice.

Fisher does not assume responsibility for the selection, use or maintenance of any product. Responsibility for proper selection, use and maintenance of any Fisher product remains solely with the purchaser.

Emerson Process Management

Fisher Controls International, LLC.
P.O. Box 8004
McKinney, Texas 75070, USA
Telephone: 1 (800) 588-5853
Telephone: 1 (469) 293-4201