

# LPG STM 94442A

## User's Manual



This Manual belongs to: \_\_\_\_\_

Company: \_\_\_\_\_

## Table of Contents

<b>Features.....</b>	<b>4</b>
<b>Hardware Installation.....</b>	<b>5</b>
<b>Monitor Mounting Dimensions.....</b>	<b>7</b>
<b>Monitor Specifications.....</b>	<b>8</b>
<b>Sender Specifications.....</b>	<b>9</b>
<b>Product Overview.....</b>	<b>10</b>
1) LCD Display.....	10
<b>Programming Low and High Set Points.....</b>	<b>11</b>
2) Alarm Relay.....	12
3) Analog Outputs.....	13
4) 4-20mA Analog Output Details.....	15
5) Connection Details.....	18
a) Connection Detail for Rochester Hall Effect Sender.....	18
b) Connection Detail for an External 4-20mA Signal Remote sender.....	21
6) -48 VDC Power Source Connection Details.....	23
<b>PC Connections Using RS232 Serial Interface.....</b>	<b>24</b>
a) RS232 Serial Port 1 Connection and Operation (DEV port).....	24
b) RS232 Serial Port 2 Connection and Operation (COM port).....	26
<b>Most Frequently Asked Questions and Answers (Q &amp; A).....</b>	<b>28</b>
<b>Warranty.....</b>	<b>29</b>

## **Features**

The 94442A Stationary Tank Monitor (STM) is used for measuring LPG level in a tank. It can be installed indoors or outdoors at a convenient location that can be up to 300 feet from the tank. A level sender is also included which must be installed in the float gage located on the tank. The LPG tank does not have to be emptied or purged to install the sender. It's universal design fits most junior and senior LPG float gages and includes a direct read pointer that can be used to indicate LPG level at the tank

- Monitors 2 LPG Tank Levels (Sensor for second tank optional)
- State-of-the-art intelligent microprocessor based electronics
- Large LCD readout indicating Level, Low Set Point and High Set Point for each channel
- Hi/Lo alarm set points programmable using built-in pushbuttons
- One Form "C" (NC-C-NO) contact available for each channel. Contact rating 120VAC @ 3 Amps
- Analog Output for each channel, 0 to 5 VDC standard, 4-20 mA optional
- RS232 Serial Interface for direct connection to PC/RTU or PLC
- NEMA 4 enclosure suitable for outdoor use
- Operates on 12 to 24 VDC power and a 120 VAC wall transformer is included for AC operation.
- One LPG sensor included to fit standard 2" junior float gage

## **Hardware Installation**

- 1) **DO NOT INSTALL THE SENDER AT THE TANK YET.**
- 2) Locate the place where the monitor is to be installed. Drill four holes according to the dimensions shown in Figure 2. Remove the lid of the monitor (undo 4 corner screws). Mount the monitor using the appropriate screws to fit through the feed-through holes on the four corners.
- 3) Temporarily connect the sender wires directly to the monitor as shown in Figure 8A .
- 4) Connect Relay contacts and Analog outputs as desired. Refer to Figure 5 and 6 respectively for connection details.
- 5) Connect power to the monitor either using the supplied 120 VAC transformer or a 10-24 VDC power source supplied by the user.
- 6) **APPLY POWER TO THE MONITOR.**
- 7) The sender level can be changed manually by holding a small magnet at the bottom of the sender and rotating it clockwise or counter-clockwise such that the pointer in the sender follows the magnet. Observe the appropriate Level reading on the LCD display (L1 or L2) It should follow the LPG level indicated by the pointer.
- 8) Set the Low and High set points using the 5 pushbuttons as described in set point programming section above. When the level on the sensor is below the low set point or above the high set point the corresponding alarm relay will activate and the offending set point will blink on the display.
- 9) Disconnect power to the unit and the LPG sender. Install sender on the LPG tank.
- 10) Install and connect the cable between the sender and the monitor. Any 4 conductor, shielded, 16 to 22 awg., multi-strand, multi conductor cable can be used for this purpose. NOTE: if this cable is not installed in a conduit, then be sure to select a good outside grade cable that can be used for direct burial if necessary.
- 11) Apply power to the unit and make sure that the monitor is displaying the correct LPG level observed at the tank.

## Overview

A finished installation will look similar to this:

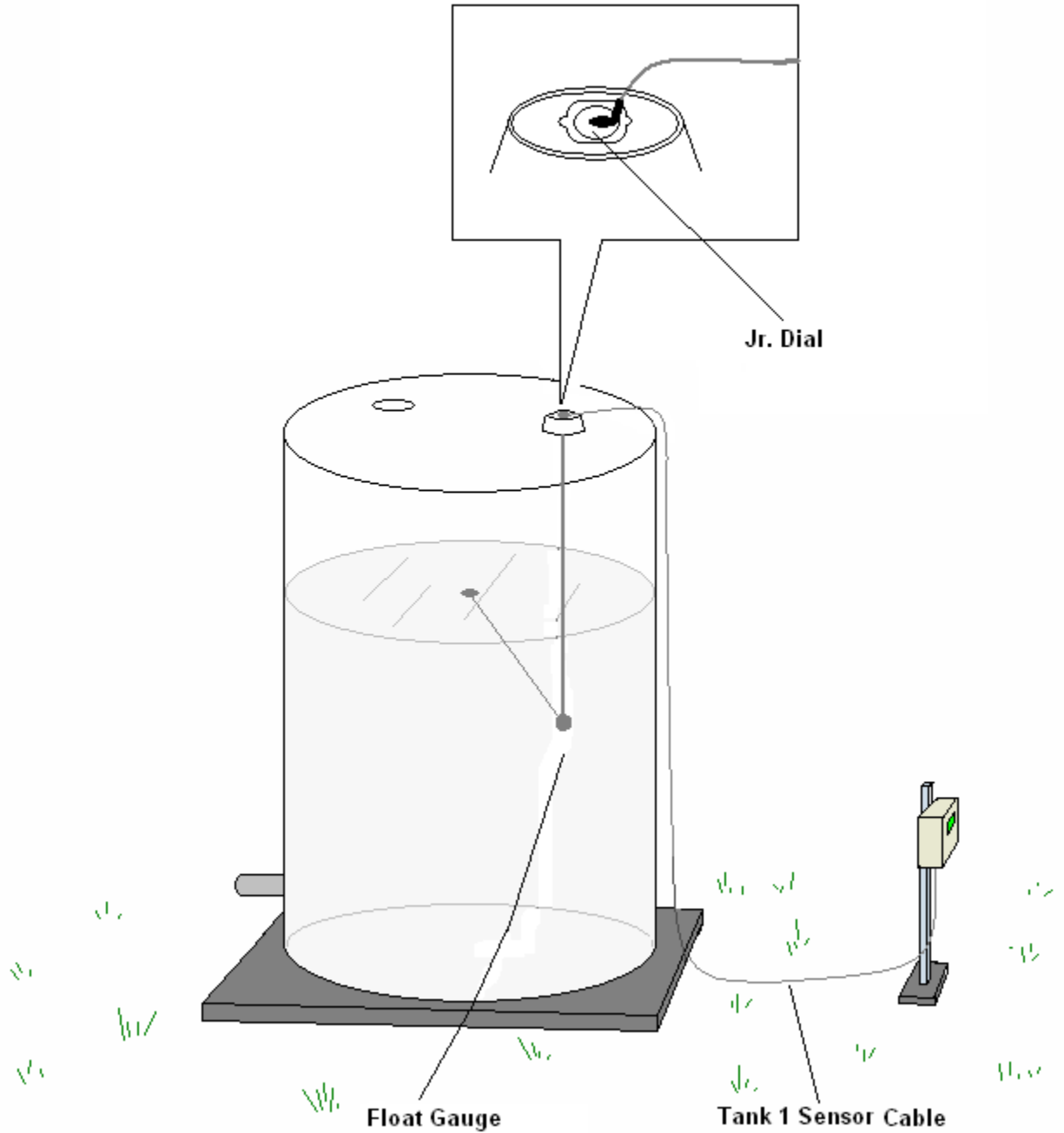

Figure 1

### Monitor mounting dimensions

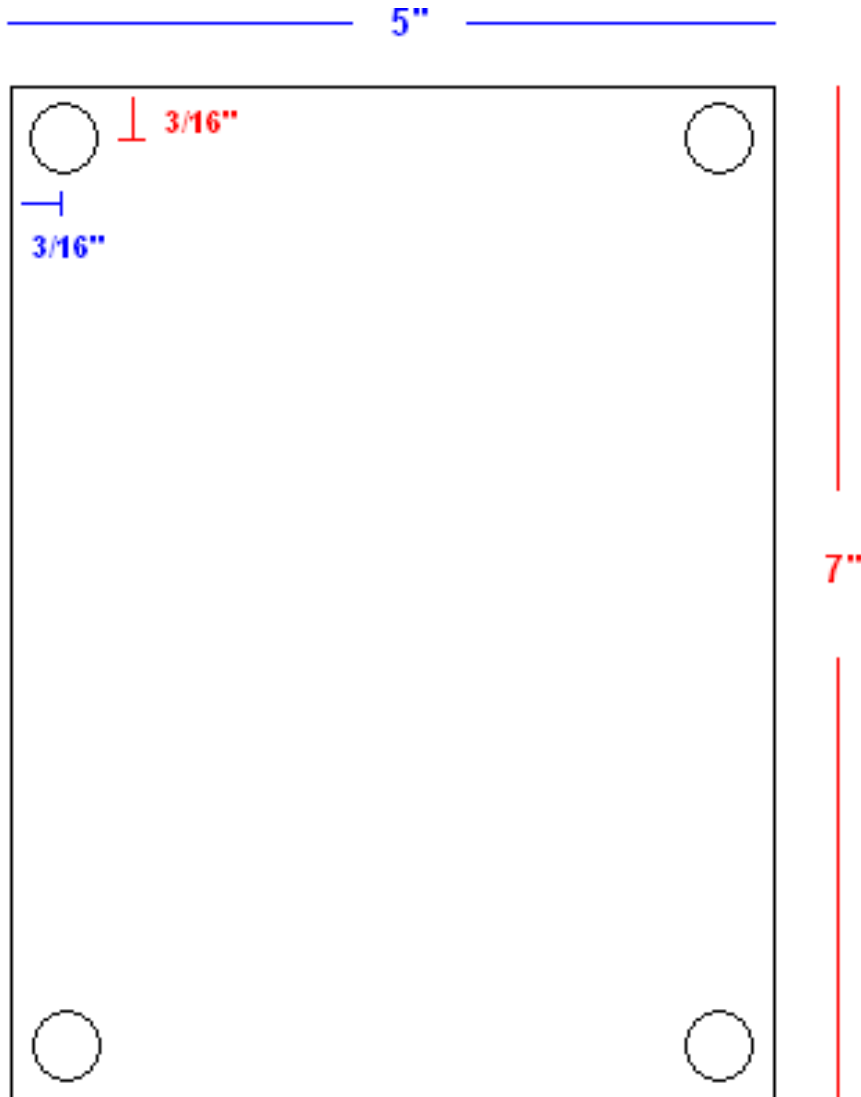

Figure 2

## Monitor Specifications

### Power

A.C. Transformer:	Input	120VAC
	Output	12 Volts DC
	Output Current	0.2 Amps

Monitor Input Power: 10-24 Volts DC

Monitor Current Consumption: 0.25 Amps max.

### Sender Output:

Maximum output voltage to sender: 5 Volts DC

Maximum output current to sender: 10 mA

### Alarm Relay specifications:

2 Form 'C' contacts rated at 5 Amps each

### Analog output:

Volts 0-5 Volts DC

Output current: 20 mA max.

### Enclosure:

NEMA 4x, sealed, weather-proof, designed for indoor or outdoor use.

Monitor operating temperature: 10 to 150 F

Monitor electrical rating: Class 1, Div. 2, groups C & D



## Sender Specifications

Operating Voltage range	0-5 Volts DC max.
Operating temperature:	-40 to 70 C -40 to 158 F
Enclosure:	Sealed – Lexan top and bottom Ultrasonically welded
Electrical specification:	

When used with STM PN#'s: 94442A, 94442A:

**Class 1, Div. 2, groups C & D**

When used with unleaded gasoline use Intrinsically Safe Barriers  
# STAHL 9001/02-093/150/00 or equivalent:

**Class 1, Div. 1, groups C & D.**





## Product Overview

The monitor contains the following:

### 1) LCD Display

Figure 3 indicates LPG level and corresponding Low and High Set points for 2 individual tanks. Top Line indicates parameters for Tank 1 and second line for Tank 2. Top Line indicates parameters for Tank 1 and second line for Tank 2.

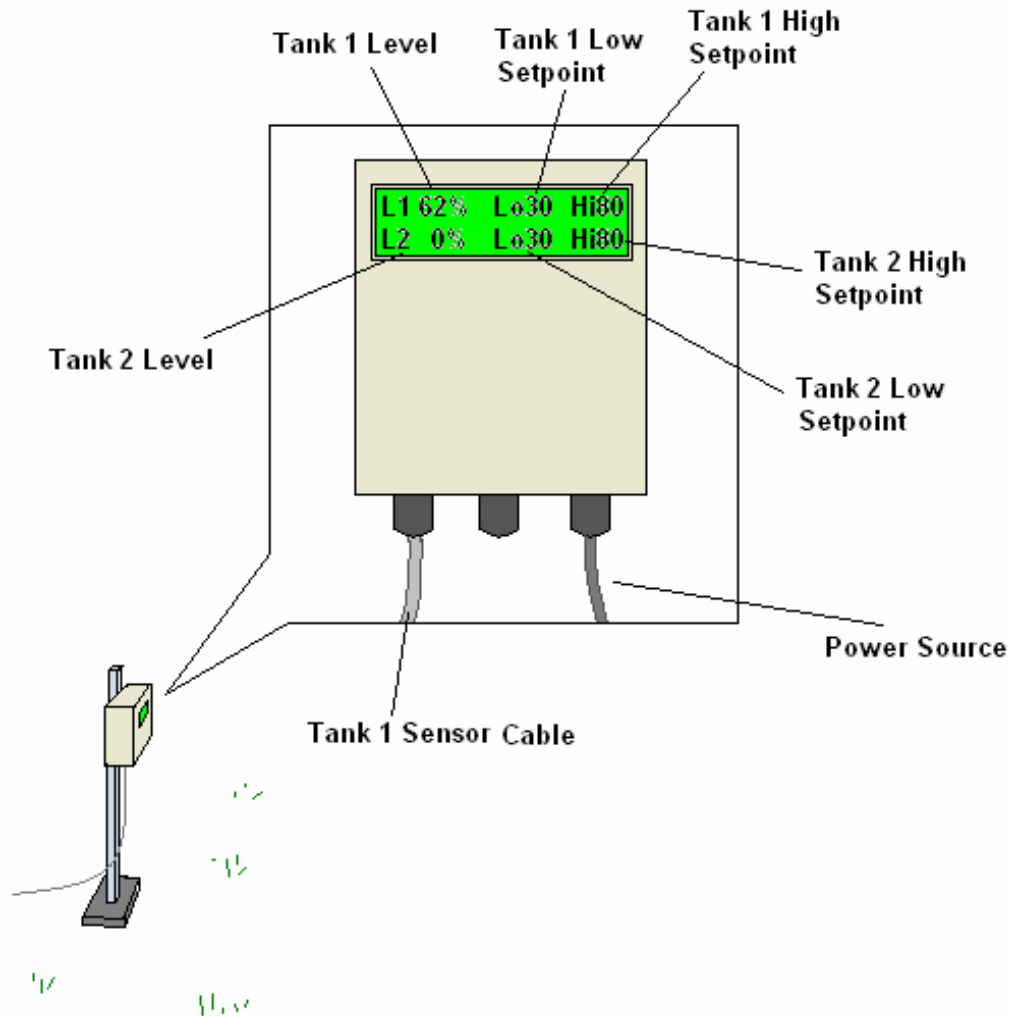

- Button 1 (blue) – Tank 1 low set point
- Button 2 (blue) – Tank 1 high set point
- Button 3 (blue) – Tank 2 low set point
- Button 4 (blue) – Tank 2 high set point
- Button 5 (red) – Reverse adjustment

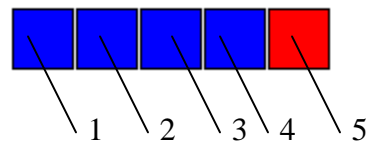

Figure 3

## Programming Low and High Set Points

There are 5 pushbuttons on the main board that are used to program the set points. Four pushbuttons are blue and are marked SW1, SW2, SW3 and SW4 from left to right. The fifth pushbutton is red and is marked SW5 and is used to change the direction of the Set Point count when being programmed by the other pushbuttons as described below. Only one set point must be modified at a time i.e. pressing SW1-SW4 at the same time may result in error. Refer to figure 4 below for details.

a) Programming Tank 1 – Low Set Point

This set point is programmed by pressing the blue push button marked SW1. The low Set point for L1 will either increase or decrease. Set it to the desired value and the unit will automatically save it. The increase/decrease direction can be changed by pressing SW5 momentarily.

b) Programming Tank 1 – High Set Point

This set point is programmed by pressing the blue push button marked SW2. The High Set point for L1 will either increase or decrease. Set it to the desired value and the unit will automatically save it. The increase/decrease direction can be changed by pressing SW5 momentarily.

c) Programming Tank 2 – Low Set Point

This set point is programmed by pressing the blue push button marked SW3. The low Set point for L1 will either increase or decrease. Set it to the desired value and the unit will automatically save it. The increase/decrease direction can be changed by pressing SW5 momentarily.

d) Programming Tank 2 – High Set Point

This set point is programmed by pressing the blue push button marked SW4. The High Set point for L1 will either increase or decrease. Set it to the desired value and the unit will automatically save it. The increase/decrease direction can be changed by pressing SW5 momentarily.

e) Programming Sensor type

Set the STM to use a Rochester 3-wire sensor by holding down the red button (SW5) and pressing SW1 to change value on the top line for channel 1 and SW2 to change value on the second line for CH2. (A value of 0 sets the unit to operate with the MDi 0-1000 2-wire sensor, **this kind of sensor is no longer used**). A value of 1 sets the unit to operate with the Rochester Hall Effect 3-wire sensor.

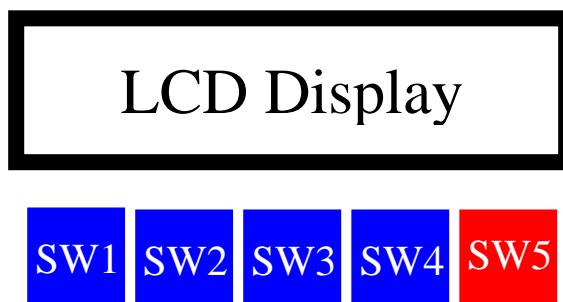

Figure 4

## 2) Alarm Relay

An alarm relay is available for each channel that provides a Form C (NC-C-NO) contact rated at 120 VAC at 3 Amps. The alarm is activated whenever the actual tank level is either lower than the LO set point or higher than the HI set point. The relay is de-activated when the level is restored within the normal operation range. Figure 5 below show connection details for the contacts.

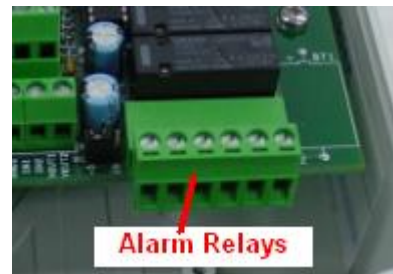
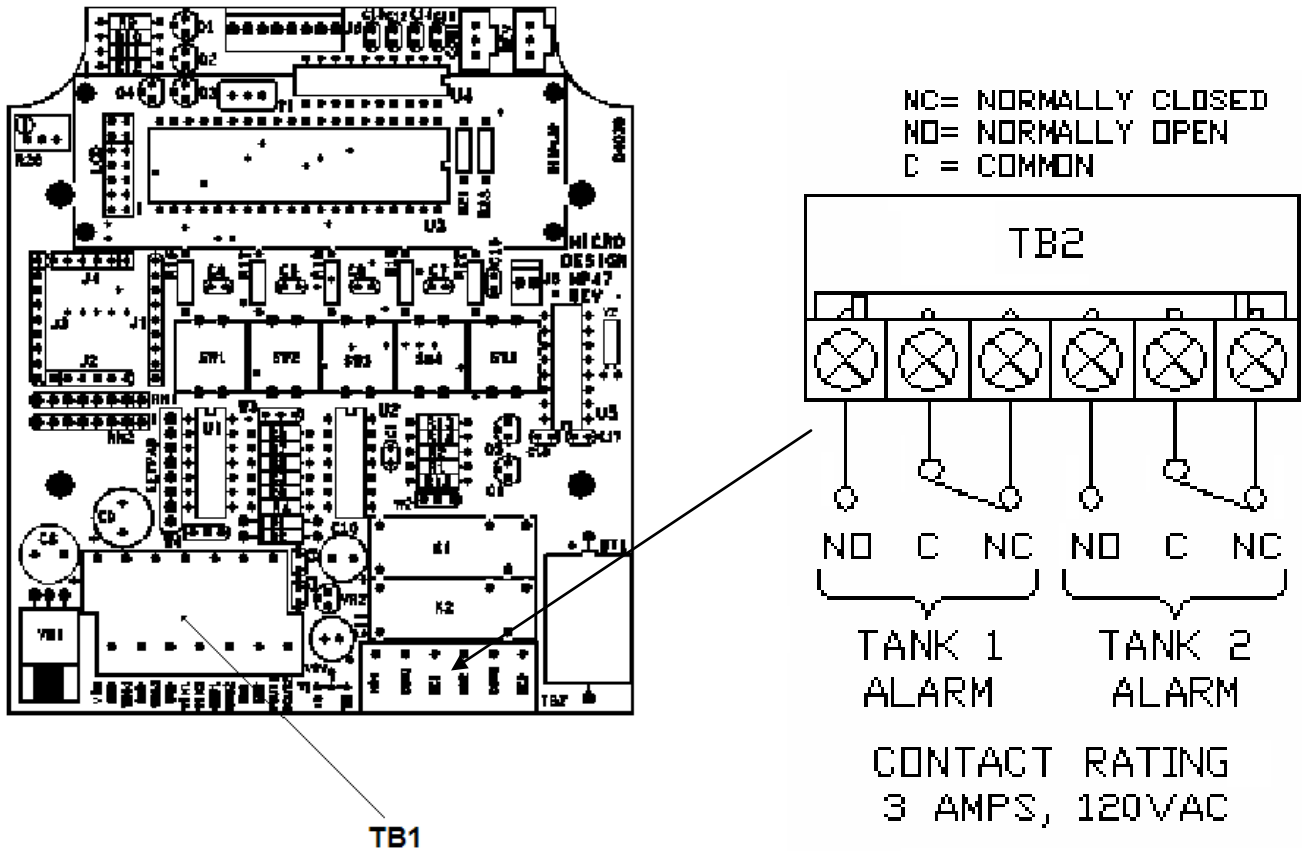

Figure 5

### 3) Analog Outputs

A 0-5 Volt analog output is also provided for each channel. This output is typically used to connect to a remote monitoring device, programmable controller, etc. in order to access LPG tank levels. For Channel 1 connect to TB1-Top Level-2 and TB1-Bottom Level-2 and for Channel 2 connect to TB1-Top Level-3 and TB1-Bottom Level-3 (refer to figure 6A below). Figure 6B shows a graph of the analog output vs. the LPG level. This output can be connected to a signal conditioner to provide a 4-20 mA signal indicative of the LPG level.

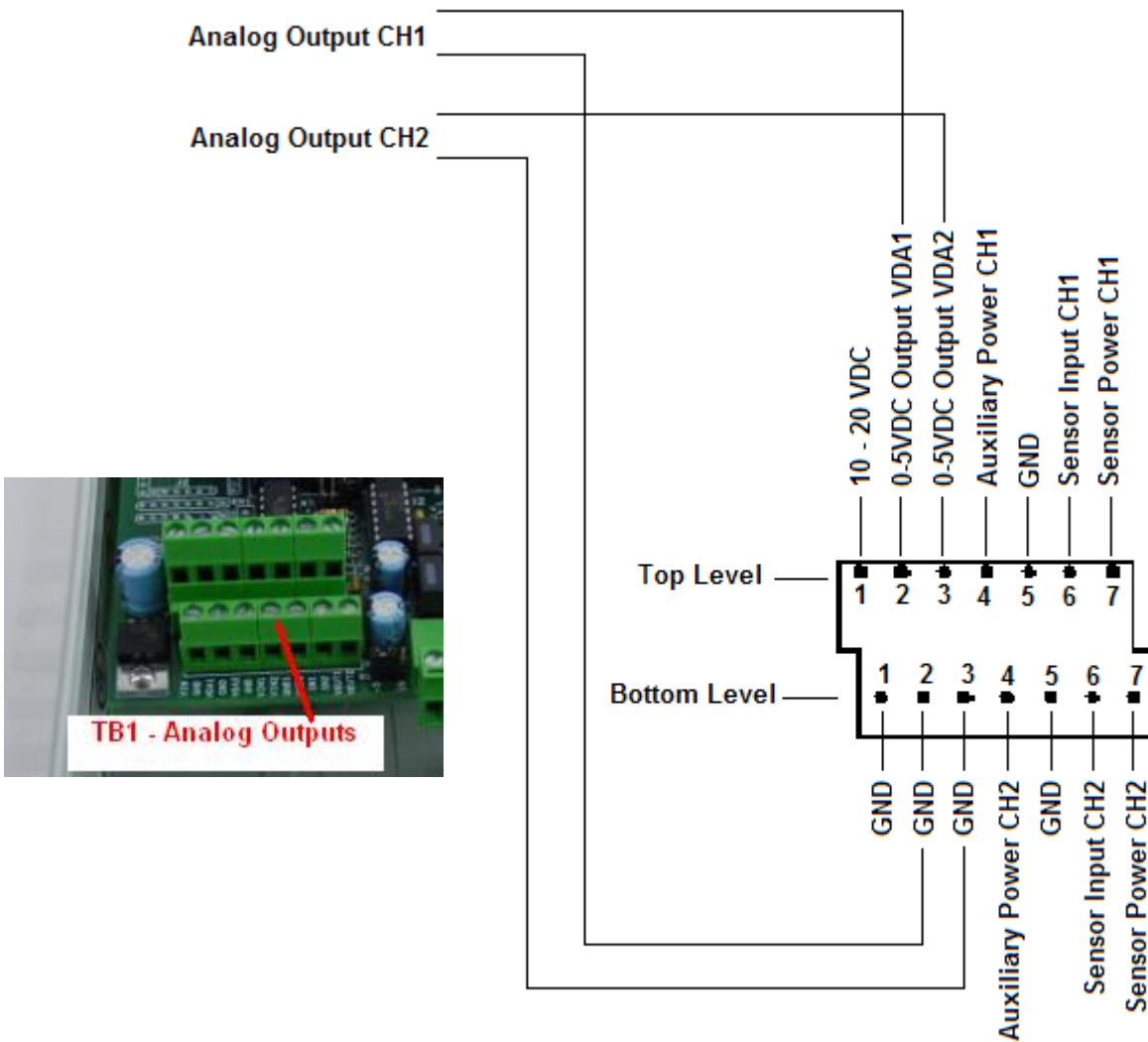

Figure 6A

Analog Output for Rochester Hall Effect Sender

% Level	Analog Output VDC
0%	0.00
5%	0.25
10%	0.50
15%	0.75
20%	1.00
25%	1.25
30%	1.50
35%	1.75
40%	2.00
45%	2.25
50%	2.50
55%	2.75
60%	3.00
65%	3.25
70%	3.50
75%	3.75
80%	4.00
85%	4.25
90%	4.50
95%	4.75
99%	4.97

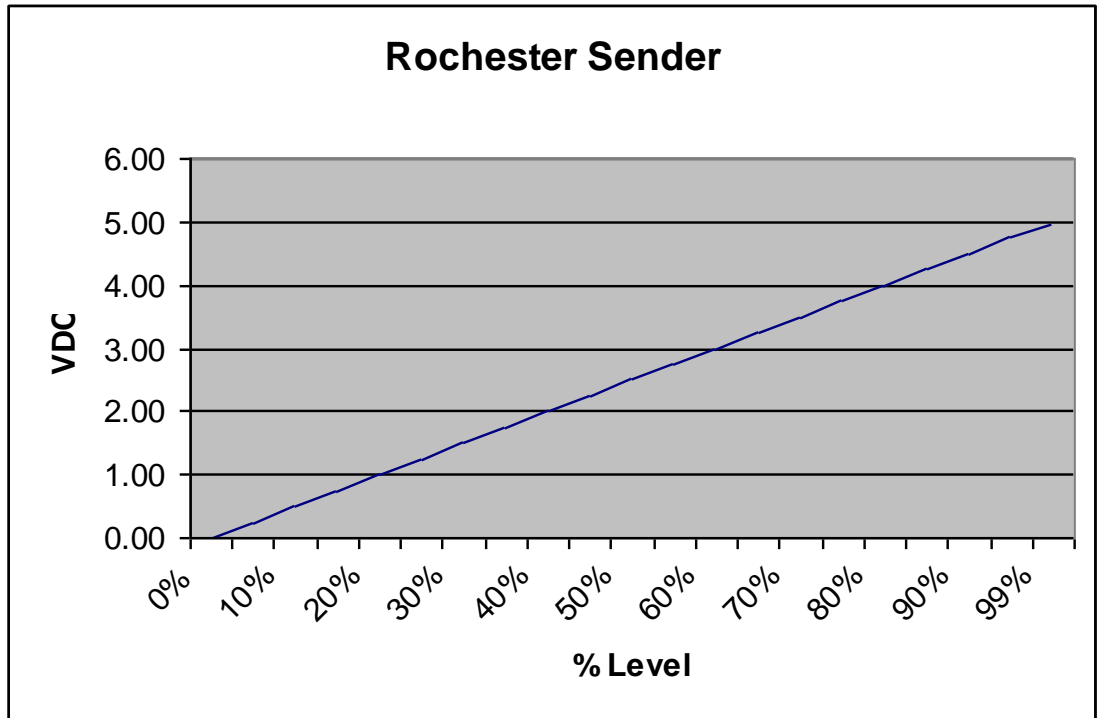

Figure 6B

4) 4-20 mA Analog Output Details

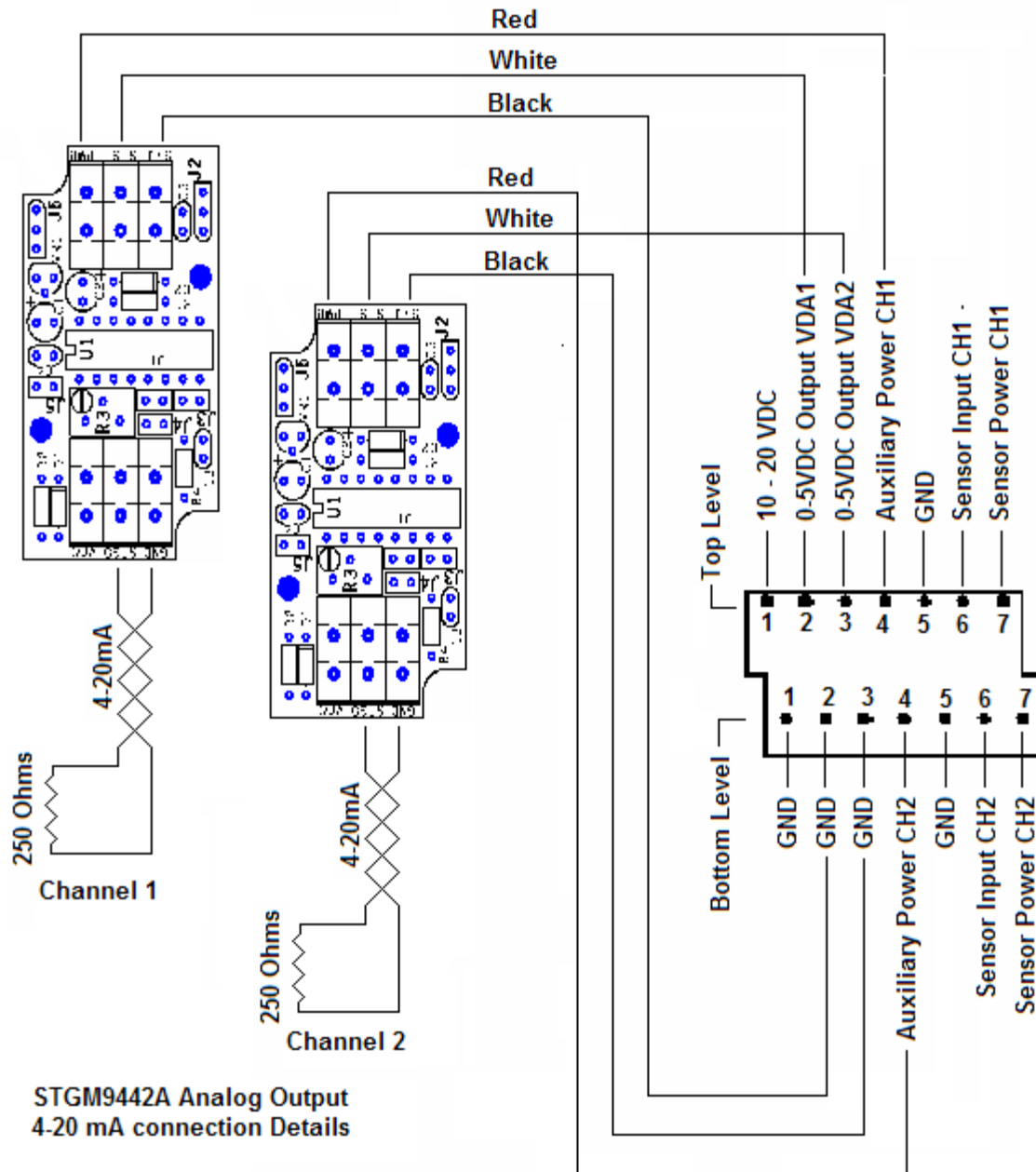
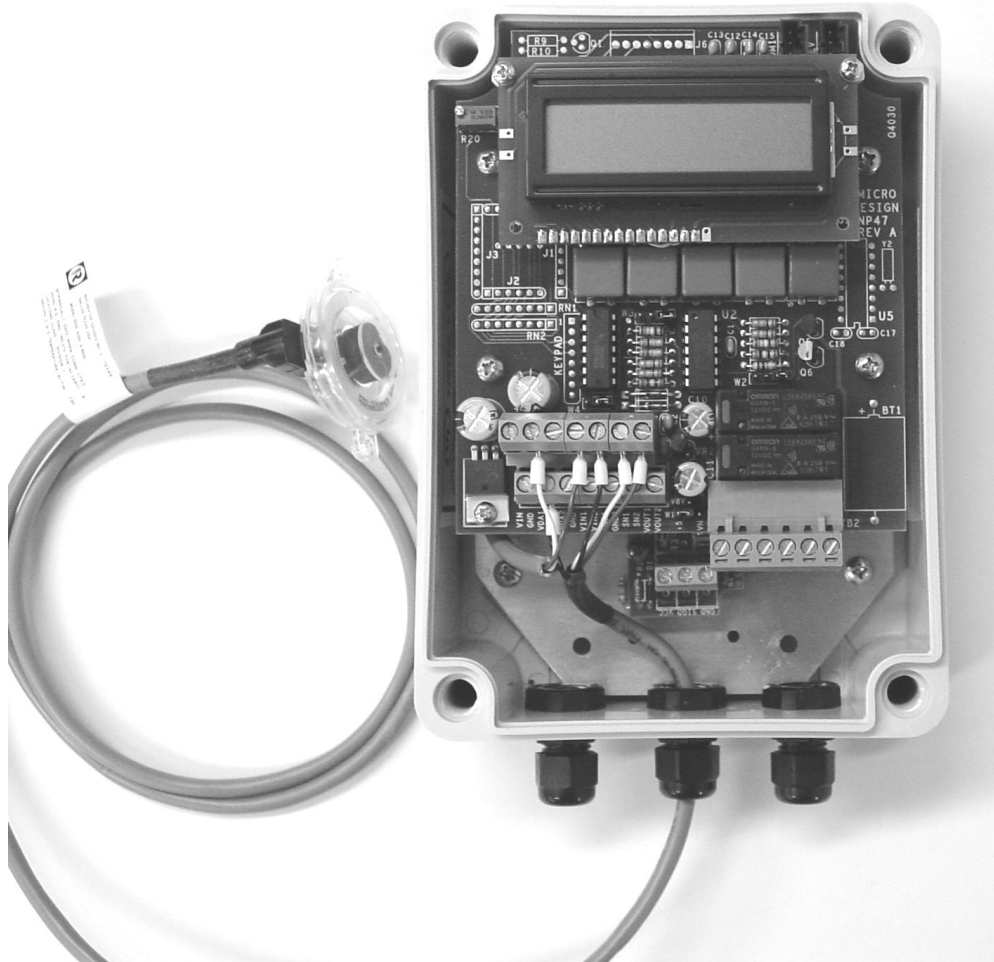

Figure 7A



STM94442A Details showing 4-20mA Analog Output board installed for Channel 1  
Figure 7B

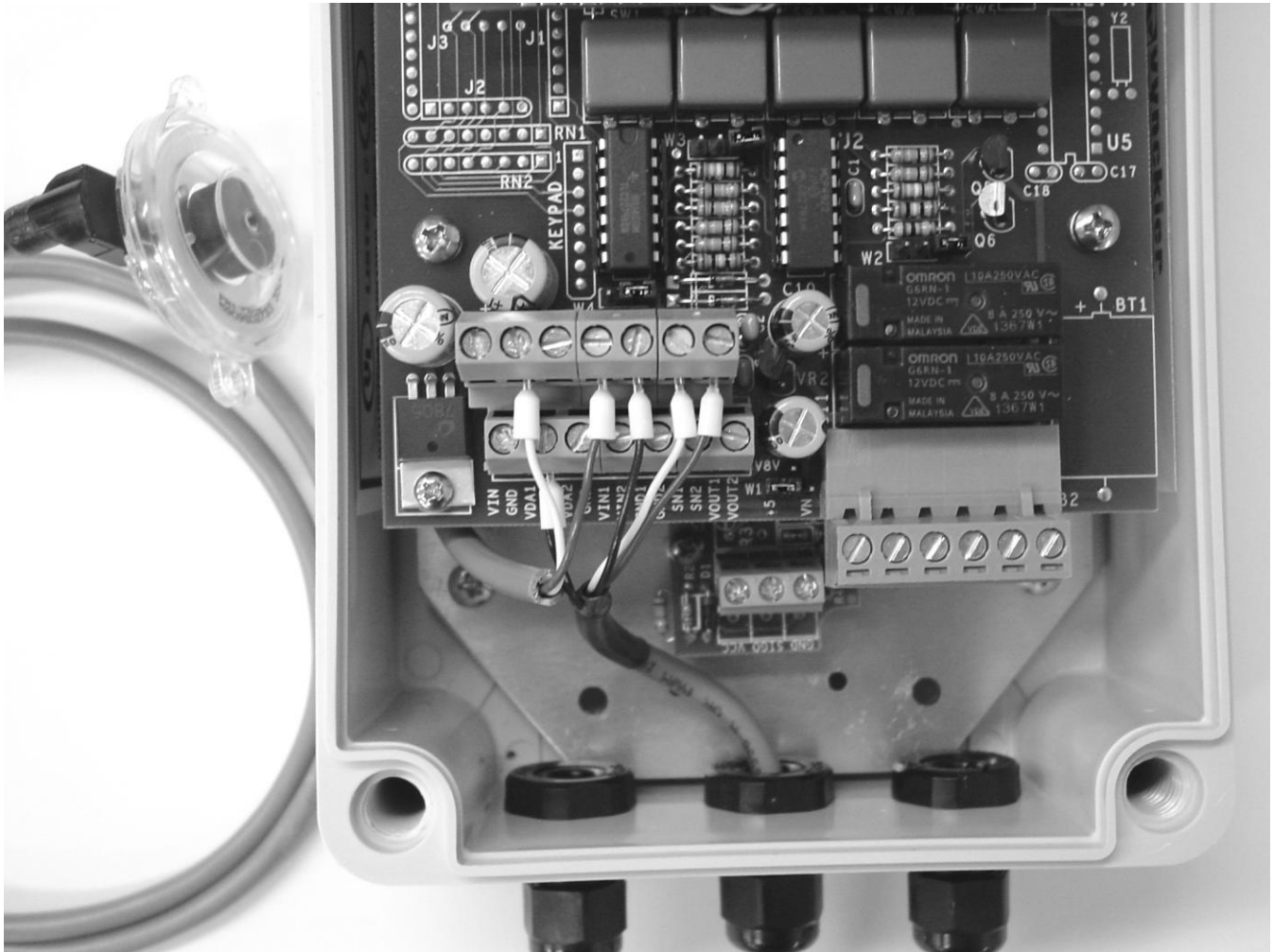

Figure 7C



5) Connection Details

a) Connection Detail for Rochester Hall Effect Sender

The Rochester Remote gage has 2 parts i.e. the plastic Direct Read dial Face and the Sensor Element that snaps into the Dial. Refer to diagram below for connection details.

Wire Color	Channel 1	Channel 2
Red	TB1 – Top Level – 7	TB1 – Bottom Level – 7
White	TB1 – Top Level – 6	TB1 – Bottom Level – 6
Black	TB1 – Top Level – 5	TB1 – Bottom Level – 5

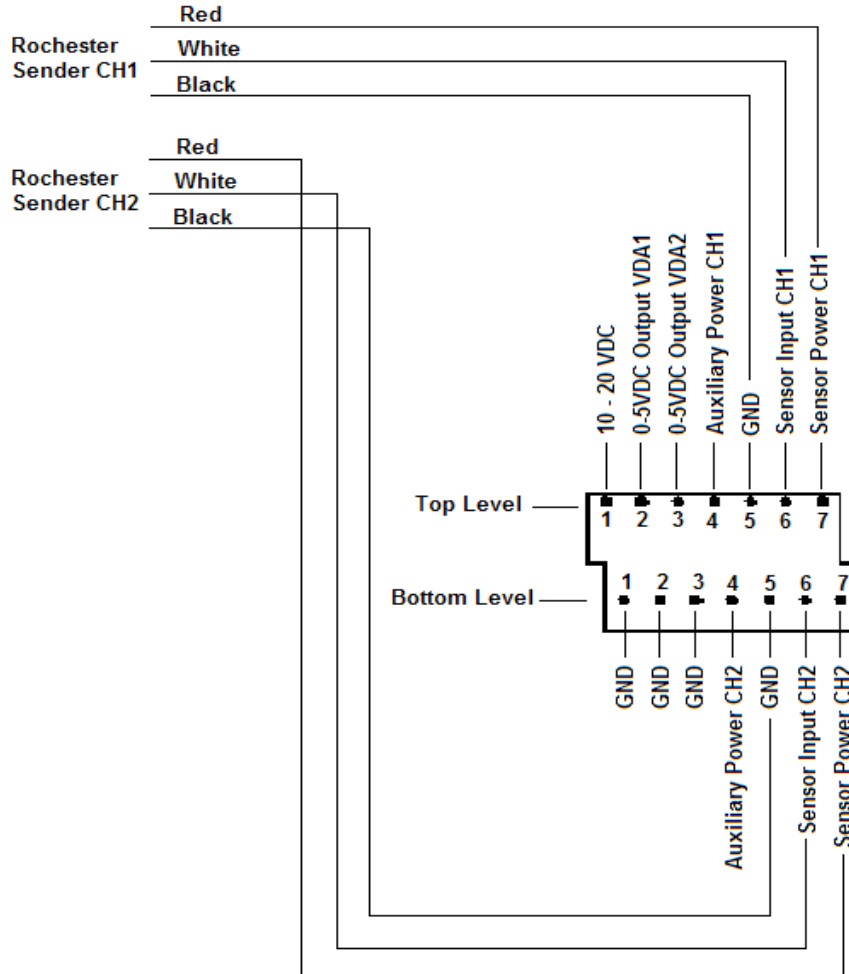

Figure 8A

Jumper Settings for Rochester Hall Effect Sender

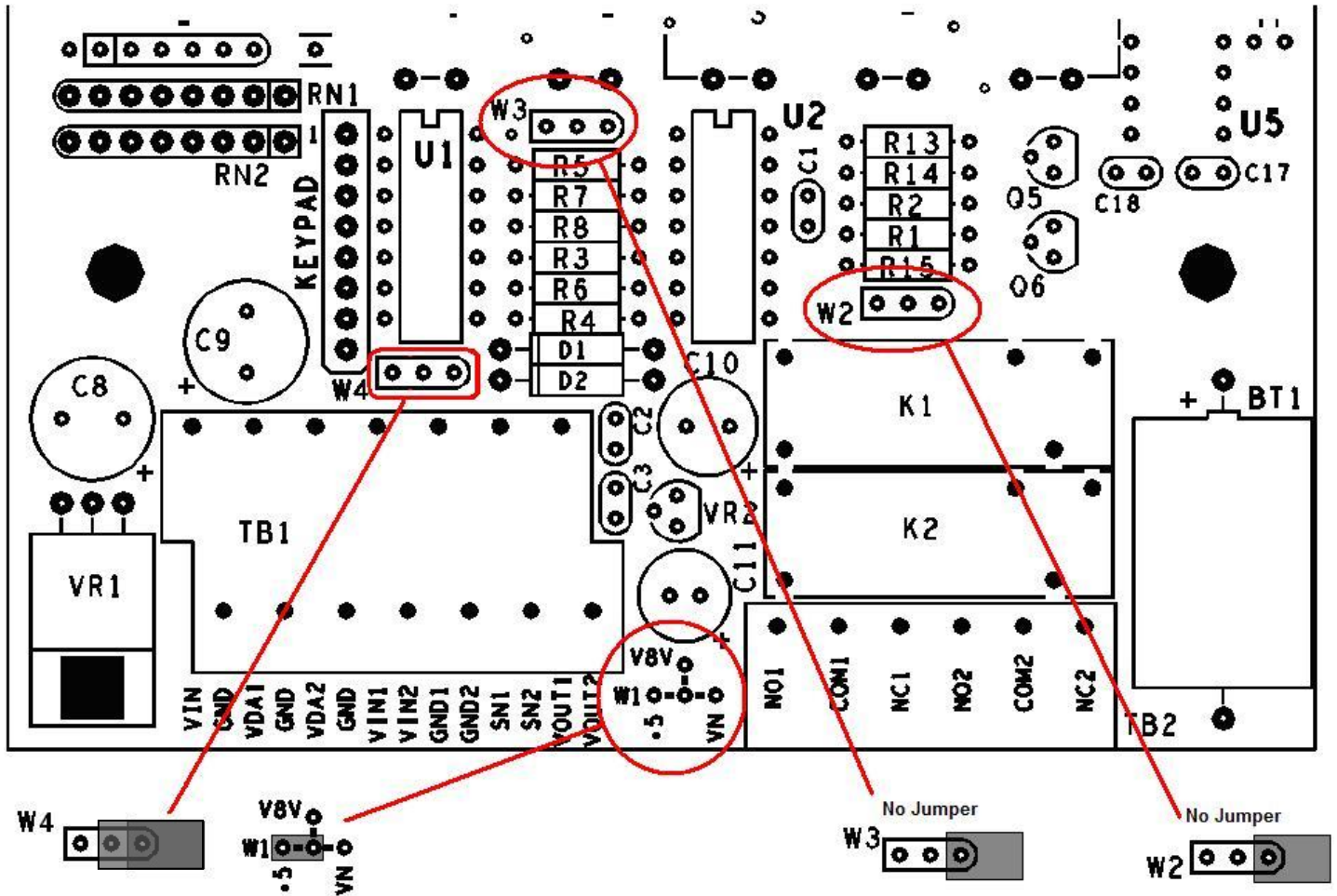
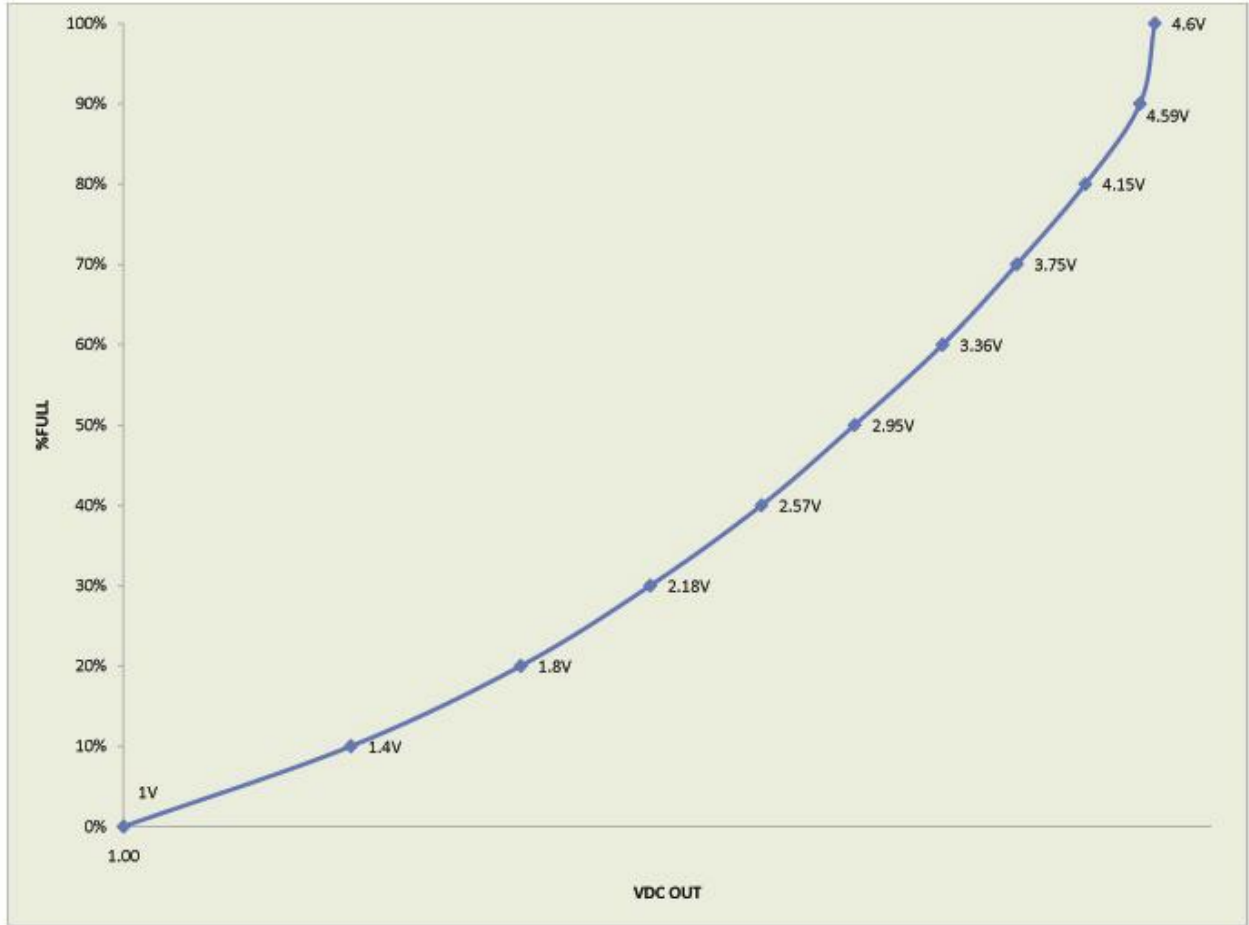

Figure 8B

LPG Stationary Tank Monitor PN#94442A – LPG 20  
For Domestic and Industrial Tanks r1.6



Connection Detail for an external 4-20mA Signal Remote Sender

Wire Color	Channel 1	Channel 2
Red	TB1 – Top Level – 7	TB1 – Bottom Level – 7
White	TB1 – Top Level – 6	TB1 – Bottom Level – 6
Black	TB1 – Top Level – 5	TB1 – Bottom Level – 5

A 3-wire 4-20 mA signal from an external device can be connected to the STM. The figure below shows connections for a 3-wire 4-20mA transmitter.

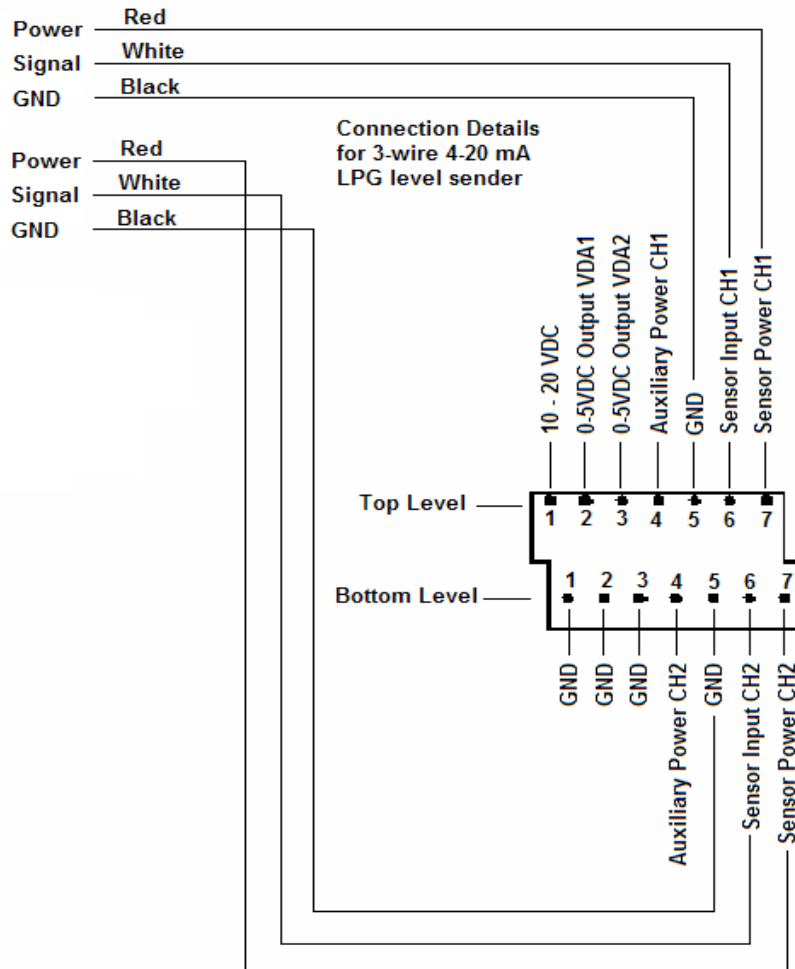

Figure 8C

Jumper Settings for 4-20mA Signal LPG level Senders

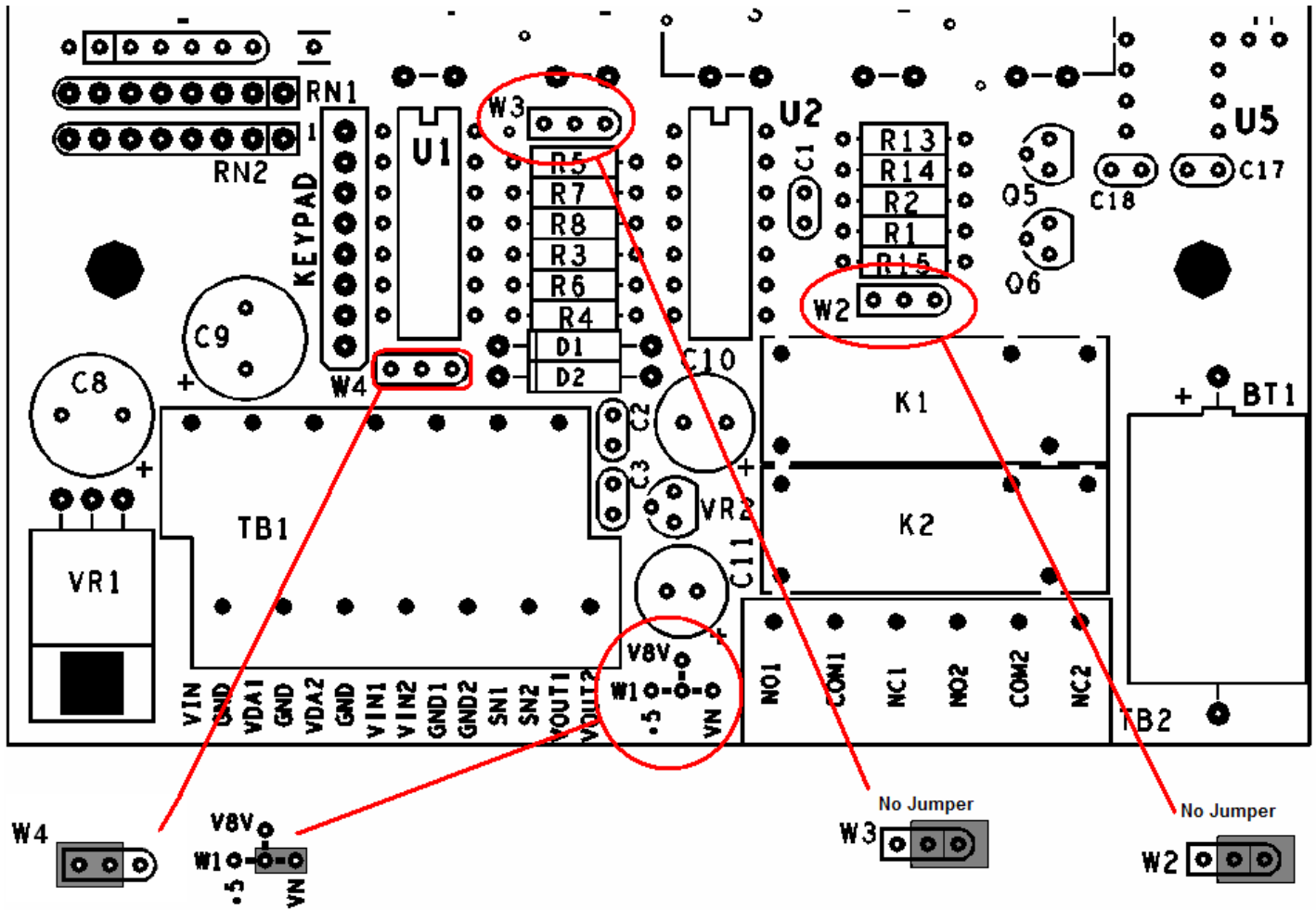
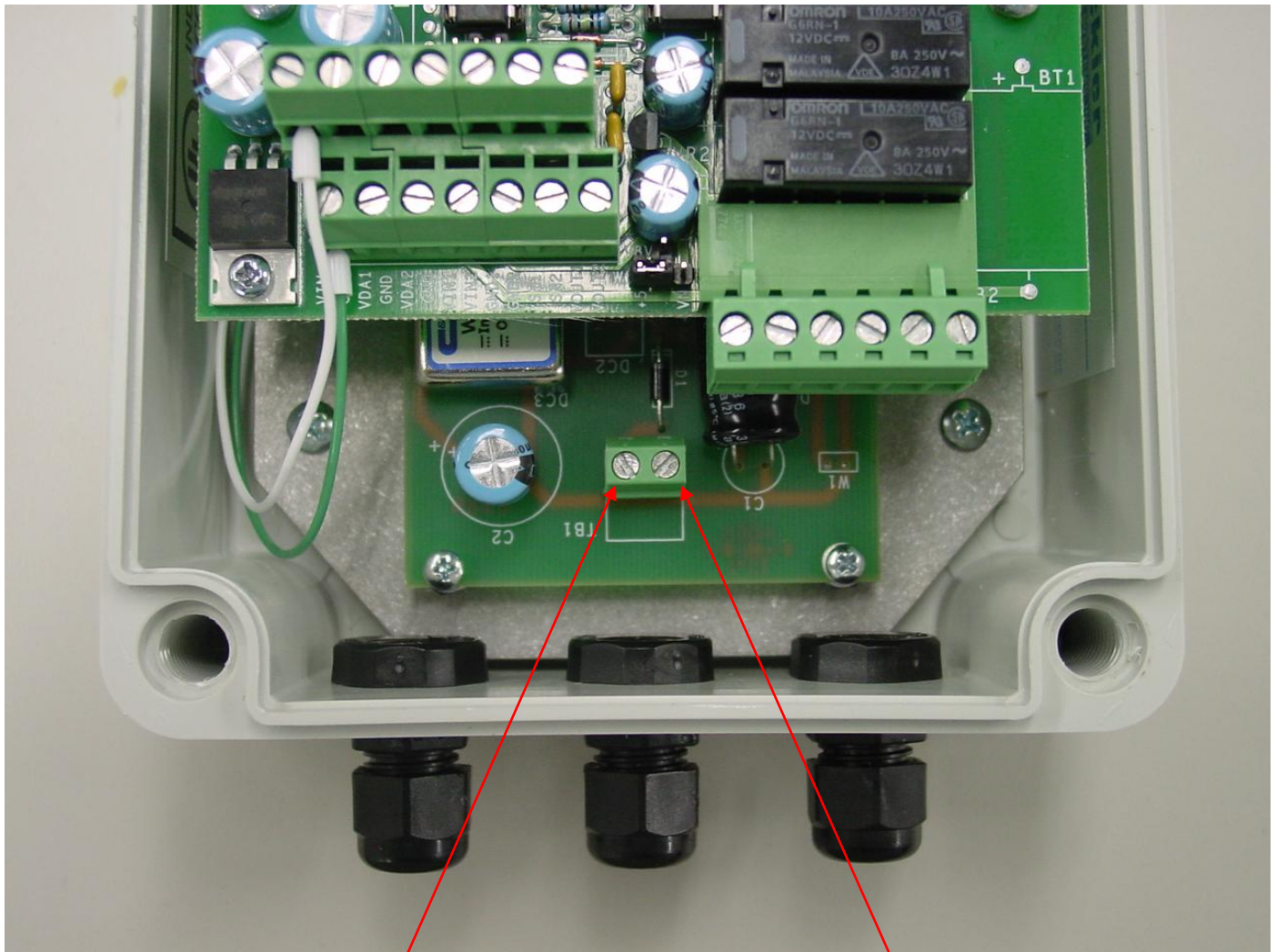

Figure 8D

6) -48 VDC Power Source Connection Details

For locations that have -48 Volts DC power source, the units needs to be isolated so that the correct DC voltages are applied to power the unit and the sensor. Connect the -48 VDC supply as shown in picture below:



+ 48 VDC

- 48 VDC

Figure 9

## PC Connections using RS232 Serial Interface

### a) RS232 serial port 1 connection and operation (DEV port)

This serial interface port can be connected to a PC using MDi cable #mdi-232-10. Using communication programs such as Microsoft HyperTerminal the user can set alarm set points, view current levels, change signal type, etc. The unit port is set to operate at 9600 BAUD, 8 data bits, 1 stop bit, no parity and no handshake. It is a simple 3-wire interface i.e. transmit, receive and ground. Once the cable is connected from the PC com port to the unit's DEV port, press enter on the HyperTerminal window and the unit will respond with a menu. This menu is self explanatory and as mentioned, parameters can be set/changed per user's requirements. Figure 10A below shows details of the HyperTerminal window with the unit menu.

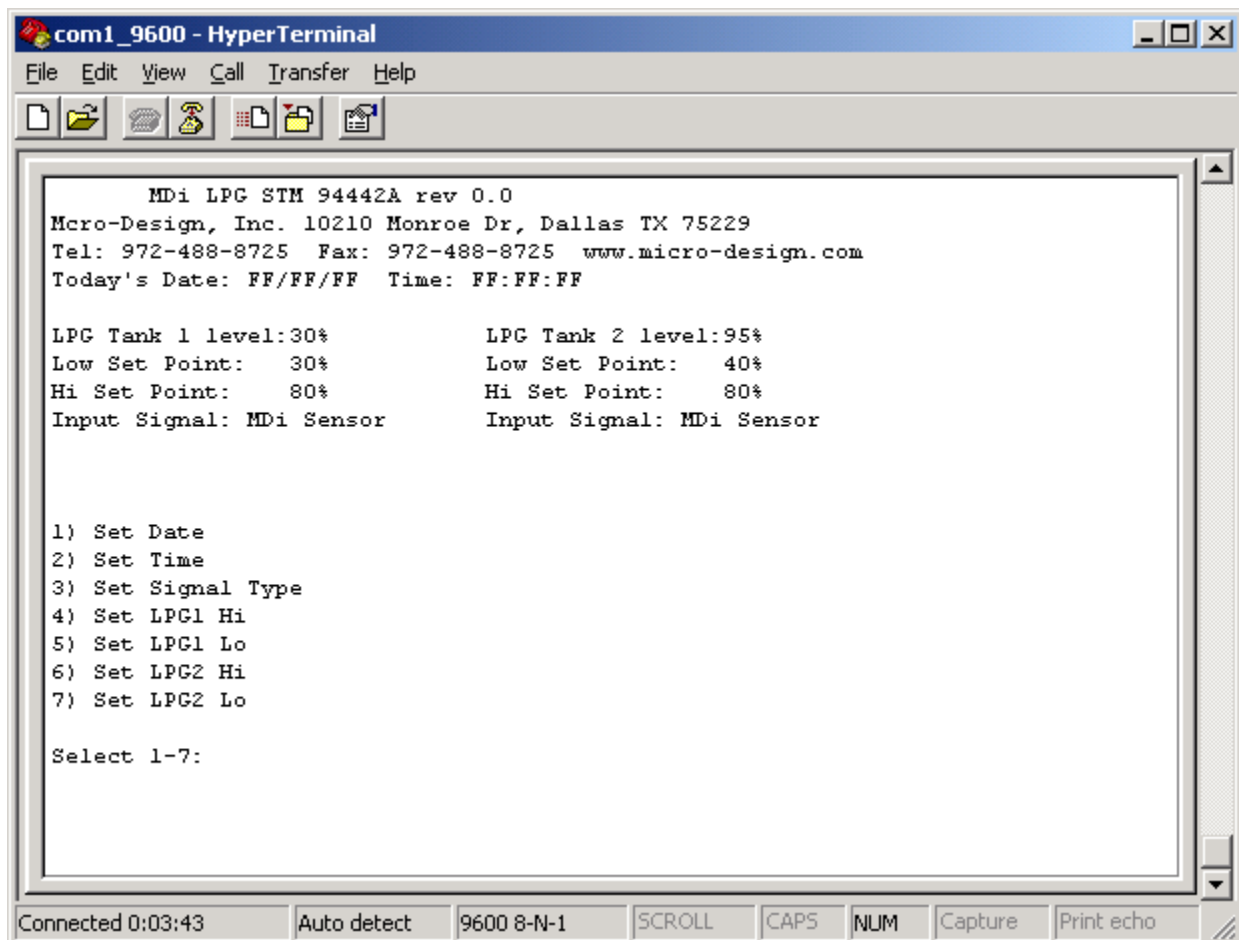

Figure 10A

Selection option “1” and “2” are not available in Model #94442A

Selection “3”: Set Sensor Signal Type

This is used for setting the type of sensor that is being connected to the STM.

“1” Rochester Hall Effect Sender

“2” 4 – 20 mA Sensor

Select “3” on Main Menu (may have to press “3” twice)

Enter “1, 1” (Unit does echo this entry so it will not show on the screen)

The unit will go back to Main Menu and should show sensor type to be 0-5 Volts DC.

If it does not repeat entry again.



**b) RS232 serial port 2 connection and operation (COM port)**

This serial port is connected the same as port 1 using MDi cable #mdi-232-10. The port is also to operate at 9600 BAUD, 8 data bits, 1 stop bit, no parity and no handshake. It continuously sends out a data packet as shown in figure 10B below. This port is primarily used to connect to a PC or a Remote Terminal Unit (RTU) to retrieve live tank level data for use in other monitoring systems.

**Data Packet**

:0395308040800000

Data	Description
:	Header ASCII character “:”
03	Tank 1 LPG Level 00% to 99%
95	Tank 2 LPG Level 00% to 99%
30	Tank 1 Low Level Alarm Set Point
80	Tank 1 High Level Alarm Set Point
40	Tank 2 Low Level Alarm Set Point
80	Tank 2 High Level Alarm Set Point
00	Tank 1 Sensor Type : 0 = MDi Sensor (not used), 1 = 0-5 VDC and 2 = 4-20mA
00	Tank 2 Sensor Type : 0 = MDi Sensor (not used), 1 = 0-5 VDC and 2 = 4-20mA
CR	Packet termination Character ASCII 10

RS232 Serial Port 2 (COM port) HyperTerminal Screen Shot

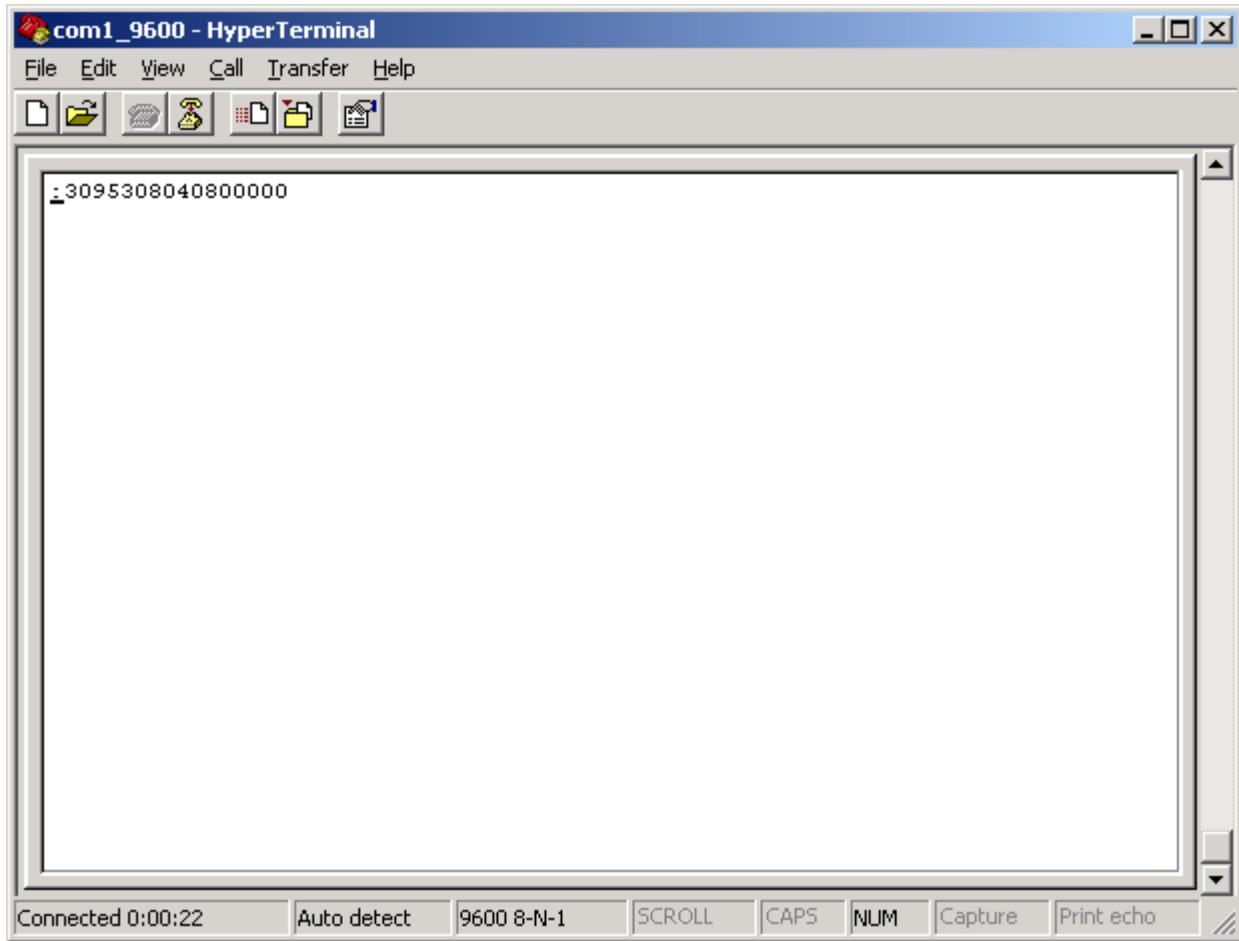

Figure 10B

## **Most frequently asked questions and answers (Q & A)**

- 1) Unit is installed but will not show anything on the display.
  - a) Check power. Make sure that Power + (10-24 VDC) is connected to TB1-VIN and Power – to TB1-GND. If 120 VAC transformer is used, make sure Wire marked “+12VDC” is connected to TB1-VIN and the other wire is connected to TB1-GND
  - b) Make sure that the sender is properly connected (Refer Figure 8A)
  - c) Check and verify that the control board inside the controller is not damaged or scratched.
  
- 2) Unit will not trip on a low level condition.
  - a) Check and make sure that the Low Level Alarm Set Point is set correctly. Refer to Set Point Programming section in this manual.

**LPG Stationary Tank Monitor PN#94442A – LPG 29**  
**For Domestic and Industrial Tanks r1.6**

This warranty covers all defects in workmanship or material for the mechanical and electrical parts (including labor costs) contained in the MDi product, for a period of 12 months from the date of purchase.

**You must keep and be able to provide your original sales invoice as proof of the date of purchase.**

**Who is covered?**

The original purchaser of this MDi product

**What will be done?**

MDi will repair or replace any mechanical, electrical part, or the monitor which proves to be defective in normal field operation use for 12 months.

**How can you get services?**

An RMA number must be provided before equipment is returned.

Contact an account manager at MDi by calling 972-488-8725

All service must be performed by an authorized MDi technician.

**THIS WARRANTY DOES NOT COVER**

Damages from improper installation

Damages in shipping

Damages from misuse, abuse, accident, alteration, lack of proper care and maintenance

Damages from services other than authorized MDi professionals

Labor, service, transportation, and shipping charges for the removal of defective parts and installation of parts beyond the initial 12-month period

Shipping costs

**THIS LIMITED WARRANTY IS GIVEN IN LIEU OF ALL OTHER WARRANTIES, EXPRESS OR IMPLIED, INCLUDING THE WARRANTIES OF MERCHANTABILITY AND FITNESS FOR A PARTICULAR PURPOSE.**

The remedy provided in this warranty is exclusive and is granted in lieu of all other remedies. This warranty does not cover incidental or consequential damages. Some states do not allow the exclusion of incidental or consequential damages, so this limitation may not apply to you. Some states do not allow limitations on how long and implied warranty lasts, so this limitation may not apply to you. The warranty gives you specific legal rights and you may have other rights, which vary from state to state.

For more information on this and other MDi products, call 972-488-8725
---

