

ME990-4F-PRK PACKING REPAIR KIT FOR: ME990-4F 4" SINGLE FLANGE INTERNAL VALVE

!!!WARNING!!!

READ AND UNDERSTAND ALL INSTRUCTIONS INCLUDED WITH THIS REPAIR KIT
RELIEVE ALL PRESSURE FROM SYSTEM BEFORE REMOVING VALVE FOR SERVICE

NOTE: Numbers in brackets [] refer to the number in the valve component list.

A. Disassembly

1. **EVACUATE ALL PRESSURE FROM SYSTEM BEFORE ANY DISASSEMBLY OR REPAIR.**
2. Remove Cotter Pin [2] from Cam Pin [3] and discard.
3. Remove Cam Pin [3] and Cam Assembly [4] and retain.
4. Remove Stub Washer [5] and retain.
5. Remove Rod Wiper [6], Bonnet [7], Female Adapter [8], (3) V-Packs [9], Male Adapter [10], Packing Washer [11], Packing Spring [13], Ejection Spring [12], Stub [14], Stem Bushing [15], and (2) Gland Bushings [16] from Valve Body [1].
6. Discard Rod Wiper [6], Female Adapter [8], (3) V-Packs [9], Male Adapter [10], and (2) Gland Bushings [16].
7. Inspect Valve Body [1] and clean if necessary, be sure interior is free of dirt, residue and foreign particles.
6. Apply lubriplate to Packing Washer [11], Male Adapter [10], inside "V" of (3) V-Packs [9], and Female Adapter [8] and install over Stub [14] oriented as shown.
7. Install Stub [14] into Valve Body [1].
8. Apply Loctite #242 to threads of Bonnet [7] and install Bonnet [7] into Valve Body [1].
9. Install Stub Washer [5] onto Stub [14].
10. Install Cam Assembly [4] on end of Stub [14] in Valve Body [1].
11. Install Cam Pin [3] and Cotter Pin [2] and bend Cotter Pin [2] around Cam Pin [3].
12. Connect the valve assembly outlet to a pressure source of at least 150 PSI. Check for leaks at all joints and stem seals using a suitable leak detector solution such as "Marshall Excelsior" leak detector.

CAUTION: DO NOT USE THE VALVE IF ANY JOINT CONTINUES TO LEAK UNDER PRESSURE

B. Reassembly

1. Install (1) Gland Bushing [16] into Stem Bushing [15].
2. Install shorter side of Stub [14] into Stem Bushing [15].
3. Install Packing Spring [13] and Ejection Spring [12] onto Stub [14].
4. Install Rod Wiper [6] and Gland Bushing [16] into Bonnet [7].
5. Apply lubriplate to Stub Shaft [14] and packing bore on Valve Body [1].

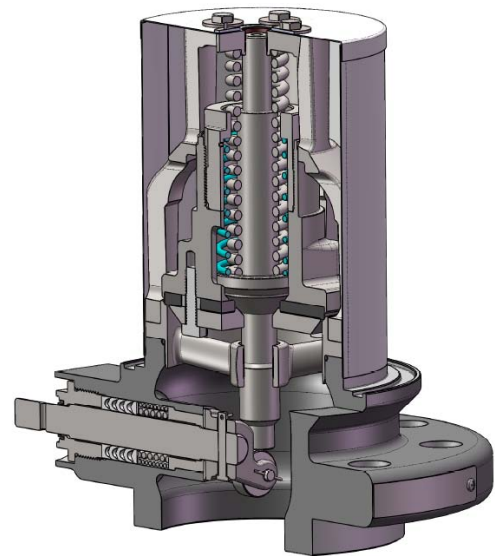

Marshall Excelsior Company

1506 George Brown Drive Marshall, MI 49068
Phone (269) 789-6700 Fax (269) 781-8340
www.marshallexcelsior.com

The contents of this publication are for informational purposes only. While every effort has been made to ensure accuracy, these contents are not to be construed as warranties or guarantees, expressed or implied, regarding the products or services described herein or for their use or applicability. Marshall Excelsior Co. reserves the right to modify or improve the designs or specifications of such products at any time without notice. The MEC™ logo is the trademark of Marshall Excelsior Co.

C. Component List

1. Valve Body
2. Cotter Pin
3. Cam Pin
4. Cam Assembly
5. Stub Washer
6. Rod Wiper
7. Bonnet
8. Female Adapter
9. V-Pack, 3 required
10. Male Adapter
11. Packing Washer
12. Ejection Spring
13. Packing Spring
14. Stub
15. Stem Bushing
16. Gland Bushing, 2 required

