



ME990-16-SRK
SEAL REPAIR KIT
FOR: ME990 2" INTERNAL VALVES

!!!WARNING!!!

READ AND UNDERSTAND ALL INSTRUCTIONS INCLUDED WITH THIS REPAIR KIT
RELIEVE ALL PRESSURE FROM SYSTEM BEFORE REMOVING VALVE FOR SERVICE

NOTE: Numbers in brackets [] refer to the number in the valve component list.

A. Disassembly

- 1. EVACUATE ALL PRESSURE FROM SYSTEM BEFORE ANY DISASSEMBLY OR REPAIR.**
2. Remove Valve Link Cotter Pin [15] and Lever [14] and retain.
3. Remove Gland Assembly [2] and Gland O-Ring [2N] from Body [1] and discard Gland O-Ring [2N].
4. Remove Spring Pin [2Q] from Cam Assembly [2R] and discard Spring Pin [2Q].
5. Remove Bonnet [2C] from Stub [2A] and Retain.
6. Remove Wiper [2B] and Gland Bushing [2D] from Bonnet [2C] and discard.
7. Remove Nylon Washer [2E], Female Adapter [2F], (3) V-Pack [2G], and Male Adapter [2H] from Stub [2A] and discard.
8. Remove Thick Washer [2J], Gland Spring [2K], and Thin Washer [2M] from Stub [2A] and retain.
9. Remove Gland [2M] from Stub [2A] and retain.
10. Remove O-Ring [2P] and Gland Bushing [2D] from Gland [2M] and discard.
11. Remove Cotter Pin [13] and Locknut [12] from Stem [3] and retain.
12. Remove Bleed Disc [11] from Stem [3] and discard.
13. Remove Valve Poppet Assembly [4] from Stem [3] and retain.
14. Remove (4) Valve Poppet Screws [4D] and Seal Retainer [4C] from Valve Poppet [4A] and retain.
15. Remove Main Valve Seal [4B] from Valve Poppet [4A] and discard.

16. Remove Excess Flow Spring [10] and Spring Seat [9] from Stem [3] and retain.
17. Remove Stem Guide [5], Upper Washer [8], Closing Spring [7], Lower Washer [6], and Stem [3] and retain.
18. Remove Guide Bushing [16] from Guide [5] and discard Guide Bushing [16].
19. Remove Stem O-Ring [17] from Stem [3] and discard.
20. Inspect Valve Body [1] and clean if necessary, be sure interior is free of dirt, residue and foreign particles.

B. Reassembly

1. Install Valve Seal [4B] into Valve Poppet [4A].
2. Install Seal Retainer [4C] onto Valve Seal [4B].
3. Apply Loctite #242 to threads of Valve Poppet [4A] and install (4) Valve Poppet Screws [4D] to retain Valve Seal [4B].
4. Install Guide Bushing [16] in Guide [5].
5. Apply Lubriplate to Stem O-Ring [17] and install on Stem [3].
6. Install Lower Washer [6], Closing Spring [7], Upper Washer [8], and Guide [5] on Stem [3] and install in Body [1].
7. Install Spring Seat [9], Excess Flow Spring [10], and Valve Holder Assembly [4] on Stem [3].
8. Apply Lubriplate to Bore of Bleed Disc [11] and install on Stem [3].
9. Install Locknut [12] and Cotter Pin [13] on Stem [3].
10. Install Gland Bushing [2D] into Gland [2M].
11. Apply Lubriplate to O-Ring [2P] and main bore of Gland [2M] and install O-Ring [2P] in Gland [2M].
12. Apply Lubriplate to large section on Stub[2A] and install in Gland [2M].

Marshall Excelsior Company

1506 George Brown Drive Marshall, MI 49068
Phone (269) 789-6700 Fax (269) 781-8340
www.marshallexcelsior.com

The contents of this publication are for informational purposes only. While every effort has been made to ensure accuracy, these contents are not to be construed as warranties or guarantees, expressed or implied, regarding the products or services described herein or for their use or applicability. Marshall Excelsior Co. reserves the right to modify or improve the designs or specifications of such products at any time without notice. The MEC™ logo is the trademark of Marshall Excelsior Co.

ME990-16-SRK
SEAL REPAIR KIT
FOR: ME990 2" INTERNAL VALVES

13. Install Thin Washer[2L], Gland Spring [2K], Thick Washer [2J], Male Adapter [2H], (3) V-Pack [2G], and Female Adapter [2F] in Gland [2M].
14. Install Nylon Washer [2E] on Stub [2A].
15. Install Rod Wiper [2B] and Gland Bushing [2D] in Bonnet [2C].
16. Apply Loctite #242 to threads of Bonnet [2C] and install into Gland [2M].
17. Install Cam Assembly [2R] on end of Stub [2A] and install Spring Pin [2Q] thru Cam Assembly [2R] and Stub [2A].
18. Apply Lubriplate to Gland O-Ring [2N] and install on Gland Assembly [2].
19. Apply Loctite #242 to threads of Gland Assembly [2] and install into Body [1].
20. Install Lever [14] and Valve Link Cotter Pin [15] on Gland Assembly [2].
21. Connect the valve assembly outlet to a pressure source of at least 150 PSI. Check for leaks at all joints and stem seals using a suitable leak detector solution such as "Marshall Excelsior" leak detector.

CAUTION: DO NOT USE THE VALVE IF ANY JOINT CONTINUES TO LEAK UNDER PRESSURE.

C. Component List

1. Body
2. Gland Assembly
- 2A. Stub
- 2B. Wiper
- 2C. Bonnet
- 2D. Gland Bushing, 2 required
- 2E. Nylon Washer
- 2F. Female Packing
- 2G. V-Pack, 3 required
- 2H. Male Packing
- 2J. Thick Washer
- 2K. Gland Spring
- 2L. Thin Washer
- 2M. Gland
- 2N. Gland O-Ring
- 2P. O-Ring
- 2Q. Spring Pin
- 2R. Cam Assembly
3. Stem
4. Valve Poppet Assembly
- 4A. Valve Poppet
- 4B. Main Valve Seal
- 4C. Seal Retainer
- 4D. Valve Poppet Screw
5. Stem Guide
6. Lower Washer
7. Closing Spring
8. Upper Washer
9. Spring Seat
10. Excess Flow Spring
11. Bleed Disc
12. Locknut
13. Cotter Pin
14. Lever
15. Valve Link Cotter Pin
16. Guide Bushing
17. Stem O-Ring, Not Shown

Marshall Excelsior Company

1506 George Brown Drive Marshall, MI 49068
Phone (269) 789-6700 Fax (269) 781-8340
www.marshallexcelsior.com

The contents of this publication are for informational purposes only. While every effort has been made to ensure accuracy, these contents are not to be construed as warranties or guarantees, expressed or implied, regarding the products or services described herein or for their use or applicability. Marshall Excelsior Co. reserves the right to modify or improve the designs or specifications of such products at any time without notice. The MEC™ logo is the trademark of Marshall Excelsior Co.

**ME990-16-SRK
SEAL REPAIR KIT
FOR: ME990 2" INTERNAL VALVES**

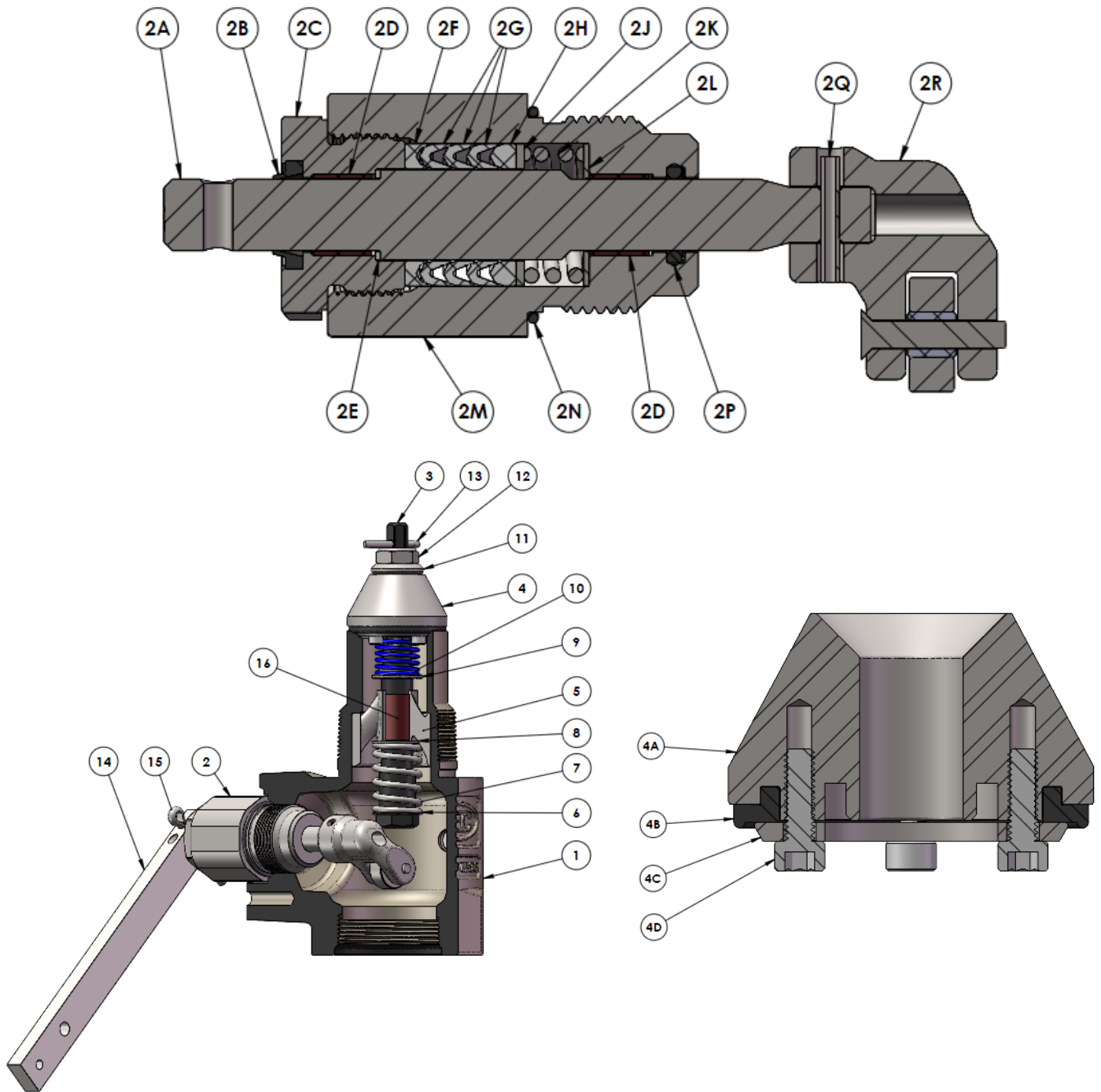

Marshall Excelsior Company

1506 George Brown Drive Marshall, MI 49068
Phone (269) 789-6700 Fax (269) 781-8340
www.marshallexcelsior.com

The contents of this publication are for informational purposes only. While every effort has been made to ensure accuracy, these contents are not to be construed as warranties or guarantees, expressed or implied, regarding the products or services described herein or for their use or applicability. Marshall Excelsior Co. reserves the right to modify or improve the designs or specifications of such products at any time without notice. The MEC™ logo is the trademark of Marshall Excelsior Co.