



**ME980-6SRK
SEAL REPAIR KIT
FOR: ME980 3/4"-1" EMERGENCY
SHUT-OFF VALVE**

!!!WARNING!!!

READ AND UNDERSTAND ALL INSTRUCTIONS INCLUDED WITH THIS REPAIR KIT
RELIEVE ALL PRESSURE FROM SYSTEM BEFORE REMOVING VALVE FOR SERVICE

NOTE: Numbers in brackets [] refer to the number in the valve component list.

A. Disassembly

1. **EVACUATE ALL PRESSURE FROM SYSTEM BEFORE ANY DISASSEMBLY OR REPAIR.**
2. Remove Handle Rod [28] and Handle Knob [29] from Handle Body [14] and retain.
3. Remove Release Pin [30] from Body [1] and retain.
4. Remove either Pneumatic Release [31] or Cable Release [32] from Body [1] and retain.
5. Remove Handle Screw [21], Handle Washer [20], Nameplate [19], Nameplate Screw [18], and Nameplate Dial [17] from Handle Body [14] and retain.
6. Remove Handle Body [14] from Stem [3] and retain.
7. Remove Handle Spring [12] from Spring Winder [13] and retain.
8. Remove Spring Winder [13], (2) Thermal Pins [16], and Square Key [15] from Handle Body [14]. Retain Spring Winder [13] and Square Key [15]. Discard (2) Thermal Pins [16].
9. Remove (4) Flange Screws [22] from Flange [2] and retain.
10. Remove Flange O-Ring [23], Graphite Seal [24], and Valve Seat [26] from Flange [2]. Discard Flange O-Ring [23], Graphite Seal [24], and Valve Seat [26].
11. Remove Stem Bearing Washer [11], Gland [10], Gland bearing [9], Stem [3], Packing Washer [8], Female V-Packing [7], V-Packing [4], and Male V-Packing [5].
12. Remove Clapper Assembly [27] from Body [1].
13. Remove Cotter pin [27A] and Valve Stem Nut [27B] from Valve Stem [27E] and retain.
14. Remove Valve Holder [27C] from Valve Stem [27E].
15. Remove Pilot Seal [27D] from Valve Holder [27C] and discard.
16. Inspect Body [1] and clean if necessary, be sure interior is free of dirt, residue and foreign particles.

B. Reassembly

1. Install Pilot Seal [27D] onto Valve Holder [27C], large diameter first. Install Valve [27C] onto Valve Stem [27E].
2. Install Valve Stem Nut [27B] onto Valve Stem [27E] until Cotter Pin [27A] can just be installed. Install Cotter Pin [27A] and bend around Valve Stem [27E].
3. Apply suitable lubricant to Male V-Packing [5], V-Packing [6], and Female V-Packing [7].
4. Install Packing Washer [8], Female V-Packing [7], V-Packing [6], Male V-Packing [5], and Packing Spring [4] onto Stem [3].
5. Apply suitable lubricant to bore of Body [1] where Stem [3] is installed.
6. Install Clapper Assembly [27] into Body [1].

Marshall Excelsior Company

1506 George Brown Drive Marshall, MI 49068
Phone (269) 789-6700 Fax (269) 781-8340
www.marshallexcelsior.com

The contents of this publication are for informational purposes only. While every effort has been made to ensure accuracy, these contents are not to be construed as warranties or guarantees, expressed or implied, regarding the products or services described herein or for their use or applicability. Marshall Excelsior Co. reserves the right to modify or improve the designs or specifications of such products at any time without notice. The MEC™ logo is the trademark of Marshall Excelsior Co.

ME980-6SRK

7. Install Stem [3] into Body [1] to retain Clapper Assembly [27].
8. Install Gland Bearing [9] onto Stem [3].
9. Apply Anti-Seize to inside of Gland [10].
10. Apply Loctite #271 to threads of Gland [10] and install onto Stem [3] into Body [1], tighten securely.
11. Install Flange O-Ring [23] and Graphite Seal [24] onto Flange [2].
12. Install Valve Seat [26] onto Valve Seat Retainer [25].
13. Install Flange [2] into Body [1].
14. Apply Loctite #271 to (4) Flange Screws [22] and install into Body [1], tighten securely.
15. Install Stem Bearing Washer [11] onto Stem [3].
16. Install Handle Spring [12] onto Spring Winder [13] and install Spring Winder [13] onto Stem [3].
17. Turn Spring Winder [13] counter clockwise until key slots line up and install Square Key [15] into key slot. Rotate Spring Winder [13] counter clockwise to ensure Clapper Assembly [27] moves freely.
18. Install Handle Body [14] onto Spring Winder [13] with holes aligned.
19. Install (2) Thermal Pins [16] into Handle Body [14]. **WARNING: To ensure safe operation use only MEC thermal pins [16].**
20. Install Nameplate Dial [17] onto Handle Body [14] with holes aligned.
21. Install Nameplate Screw [18] into recessed hole into Nameplate Dial [17] and tighten.
22. Install Nameplate [19] onto Nameplate Dial [17].
23. Install Handle Washer [20] onto Handle Screw [21]. Apply Loctite #271 to Handle Screw [21] and install into Stem [3], tighten making sure Nameplate [19] still moved freely.
24. Install either the Pneumatic Release [31] or Cable Release [32] into Body [1].
25. Install Release Pin [30] into Body [1] to retain either Pneumatic Release [31] or Cable Release [32].
26. Apply Loctite #271 to threads of Handle Rod [28] and install into Handle Body [14], tighten.
27. Connect the valve assembly outlet to a pressure source of at least 150 PSI. Check for leaks at all joints and stem seals using a suitable leak detector solution such as "Marshall Excelsior" leak detector.
CAUTION: DO NOT USE THE VALVE IF ANY JOINT CONTINUES TO LEAK UNDER PRESSURE.

C. Component List

1. Body
2. Flange
3. Stem
4. Packing Spring
5. Male V-Packing
6. V-Packing
7. Female V-Packing
8. Packing Washer
9. Gland Bearing
10. Gland
11. Stem Bearing Washer
12. Handle Spring
13. Spring Winder
14. Handle Body
15. Square Key
16. Thermal Pin; Qty:2
17. Nameplate Dial
18. Nameplate Screw
19. Nameplate
20. Handle Washer
21. Handle Screw
22. Flange Screw; Qty:4
23. Flange O-Ring
24. Graphite Seal
25. Valve Seat Retainer
26. Valve Seat
27. Clapper Assembly
 - 27A. Cotter Pin
 - 27B. Valve Stem Nut
 - 27C. Valve Holder
 - 27D. Pilot Seal
 - 27E. Valve Stem
28. Handle Rod
29. Handle Knob
30. Release Pin
31. Pneumatic Release
32. Cable Release

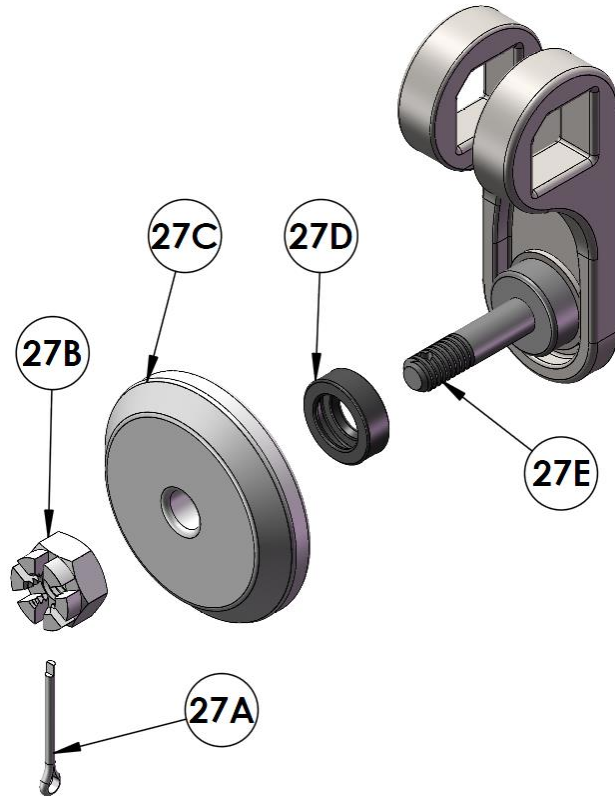

ME980-6SRK

