

**ME821SRK
 SEAL REPLACEMENT KIT
 FOR: ME821 ECONOMY QUICK ACTING VALVE**

!!!WARNING!!!

READ AND UNDERSTAND ALL INSTRUCTIONS INCLUDED WITH THIS REPAIR KIT
 RELIEVE ALL PRESSURE FROM SYSTEM BEFORE REMOVING VALVE FOR SERVICE

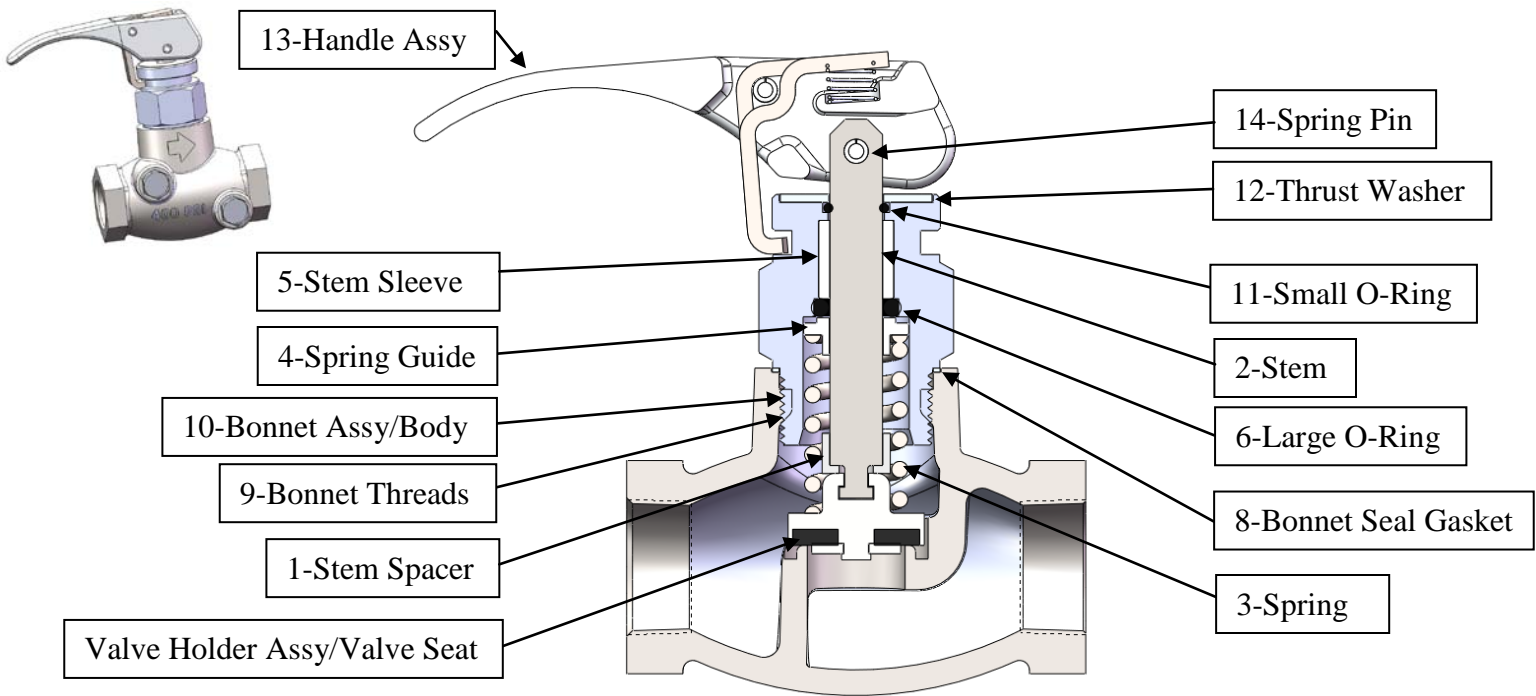

Disassemble:

1. Remove spring pin from handle assembly and discard
2. Remove bonnet assembly from body
3. Remove stem assembly from bonnet
4. Remove and discard valve holder assembly, stem spacer, spring guide, stem sleeve, bonnet seal gasket, both O-rings and stem

Reassemble:

1. Install new stem spacer on stem
2. Install new stem in new valve holder assembly
3. Install spring on stem
4. Install new spring guide on stem
5. Install new stem sleeve in bonnet
6. Apply silicone grease to new large O-ring and install in bonnet groove
7. Install stem assembly in bonnet assembly
8. Install new bonnet seal gasket in groove on body
9. Apply thread sealant to threads on bonnet
10. Install bonnet assembly in body and tighten
11. Install new small O-ring over stem and in groove in bonnet
12. Install thrust washer over stem and in recess of bonnet
13. Install handle assembly on stem
14. Install new spring pin through handle and stem
15. Connect the valve assembly inlet to a pressure source of at least 150 PSI. Check for leaks (as evidenced by bubbles) at all joints and sealing surfaces by submersing the valve in water, or using a suitable leak detector solution such as "Marshall Excelsior" leak detector. **CAUTION: DO NOT USE VALVE IF ANY JOINT OR SEALING SURFACE CONTINUES TO LEAK UNDER PRESSURE.**

Marshall Excelsior Company

1506 George Brown Drive Marshall, MI 49068
 Phone (269) 789-6700 Fax (269) 781-8340
 www.marshallexcelsior.com

The contents of this publication are for informational purposes only. While every effort has been made to ensure accuracy, these contents are not to be construed as warranties or guarantees, expressed or implied, regarding the products or services described herein or for their use or applicability. Marshall Excelsior Co. reserves the right to modify or improve the designs or specifications of such products at any time without notice. The MEC™ logo is the trademark of Marshall Excelsior Co.

Marshall Excelsior Company (MEC) would like to provide you with information regarding the hazards associated with Liquefied Petroleum Gas (LPG) and anhydrous ammonia (NH₃) equipment. All MEC products must be installed and maintained in accordance with NFPA 58 "Liquefied Petroleum Gas Code", NFPA 59 "Utility LP-Gas Plant Code" for LPG, and ANSI Standard K61.1 for NH₃, as well as all other applicable state, federal and local requirements. In the interest of safety, all persons employed in handling LPG and NH₃ must be trained in proper handling and operating procedures.

MEC products are mechanical devices that are subject to wear, contaminants, corrosion, and aging of components made of materials such as rubber and metal. Over time these devices will eventually become inoperative. The safe service life of these products is affected by the environment and conditions of use that they are subjected to. MEC products have a long record of quality and service, so managers and service personnel must keep in mind the hazards that can arise from using aging devices that have outlived their safe service life.

!!! WARNING !!!

Contact with, or inhalation of liquid propane, anhydrous ammonia, and their vapors can cause serious injury and death! NH₃ and LPG must be released outdoors in air currents that will ensure dispersion to prevent exposure to people and livestock and in accordance with local regulations. LPG must be kept far enough from open flame or other sources of ignition to prevent fire or explosion! LPG vapor is heavier than air and will not disperse or evaporate rapidly if released in still air! An abundant supply of clean water must be readily available and easily accessible as a means of providing IMMEDIATE First Aid treatment for exposure to anhydrous ammonia.

!!! CAUTION !!!

- Always wear suitable eye protection, gloves and protective clothing when operating or servicing LPG and NH₃ equipment.
- Check seals, seats and Acme threads for wear and damage before use. Repair or replace all defective parts immediately.
- Always completely relieve system or line pressure prior to servicing equipment and plumbing.
- Use a suitable sealant on tapered pipe joints and always pressure test for leaks prior to returning to service.
- Always replace protective dust caps after use.
- To prevent the accidental opening of any valve, never carry or grasp a valve by its hand wheel or handle.
- To prevent accidental discharge, introducing contaminants and premature wear, never intentionally drag or drop a hose end valve.
- Use only the special wrenches designed for making 2-1/4" and 3-1/4" Acme valve connections.
- Regular inspection and maintenance is essential for continued safe operation.

There are developing trends in state legislation and proposed national legislation making the owner of products responsible for replacing products before they outlive their safe service life. LP-Gas dealers should be aware of such legislation as it affects them.

The contents of this publication are for informational purposes only. While every effort has been made to ensure accuracy, these contents are not to be construed as warranties or guarantees, expressed or implied, regarding the products or services described herein or for their use or applicability.

Marshall Excelsior Co. reserves the right to modify or improve the designs or specifications of such products at any time without notice.

The MEC™ logo is the trademark of Marshall Excelsior Co.

Hose End and Filling Valves

Follow this procedure on every filling application in order to prevent hazardous conditions:

- Check hose end valve and filler valve for foreign materials and, if present, remove with extreme care. If foreign material cannot be safely removed, do not proceed with filling and replace valve.
- Make sure the Acme connector easily spins on by hand. Never use hammers or pipe wrenches to tighten Acme connections.
- If a leak is detected when filling is started, immediately stop the operation and follow procedures to correct the leaking condition.
- Before disconnecting a filler valve, close both the filler and hose end valve tightly and vent the trapped gas by (a) using the vent on the hose end valve or (b) slightly loosening coupling nut to vent the gas before disconnecting. Loosen the filler valve very slowly. If the gas does not stop venting, then there is a leak in the filler valve or hose end valve. Do not disconnect the filling connector. Make sure you are familiar with your companies' procedure for handling this hazardous situation and follow it carefully.

Back Checks and Valves with Back Checks

Back checks limit flow to one direction. They are not intended to be a primary shut-off. Always fully close shut-off valves equipped with back checks when not in use.

Excess Flows and Valves with Excess Flows

Excess flows check closed when their rated flow is exceeded. Always fully open a shut-off valve with an excess flow when in use.

Quick Acting Filling Valves

Inspect valves daily to ensure locking mechanism is working properly.