

# ME217PIB / ME503PIB

## SMART INTERLOCK TECHNOLOGY ACME ADAPTER INTERLOCK BRACKET INSTALLATION AND OPERATING INSTRUCTIONS



**Application:**

Designed to incorporate (MEC) Smart Interlock Technology with our 1-3/4" and 3-1/4" Male Acme Adapters. (MEC) Smart Interlock Technology is designed for direct connection to Allison® automatic transmissions through the "auxiliary function range inhibit" or braking systems for manual transmission vehicles. (MEC) Smart Interlock Technology prevents the vehicle from being operated while the truck is being loaded. This revolutionary system incorporates the industry's best and most durable sensor - Turck® - which are backed with a lifetime product warranty.

**Features:**

- Molded urethane sensor body housing for durability and maximum sensor protection
- Stainless steel mounting band and hardware
- Supplied standard with (MEC) Smart Interlock Technology
  - Interlock technology features Turck® proximity switch for maximum weather resistance and security against vibration
  - Supplied with water tight conduit and necessary wiring hardware to reach 5' below deck with water tight receptacle plug
  - Optional wiring harness cable kits available in 20' or 30' lengths

Part #	Description
<b>ME217PIB</b>	(MEC) Smart Interlock Bracket Kit for ME200 Series 1-3/4" M. Acme Adapters
<b>ME503PIB</b>	(MEC) Smart Interlock Bracket Kit for ME503-16 & ME252-16 3-1/4" M. Acme Adapters
Accessories	
Part #	Description
<b>ME229F5</b>	1-3/4" F. Acme Brass Cap w / 5-1/2" Stainless Steel Flange (For use w / ME217PIB)
<b>ME229F5-1</b>	1-3/4" F. Acme Brass Cap w / 5-1/2" Stainless Steel Flange & Chain Assembly (For use w / ME217PIB)
<b>ME229F5-1C</b>	1-3/4" F. Acme Brass Cap w / 5-1/2" Stainless Steel Flange & Cable Assembly (For use w / ME217PIB)
<b>ME441F8</b>	3-1/4" F. Acme Cap w / 8" Stainless Steel Flange (For use w / ME503PIB)
<b>ME441F8-1</b>	3-1/4" F. Acme Cap w / 8" Stainless Steel Flange & Chain Assembly (For use w / ME503PIB)
<b>ME441F8-1C</b>	3-1/4" F. Acme Cap w / 8" Stainless Steel Flange & Cable Assembly (For use w / ME503PIB)
<b>MEP801PC/20</b>	20' Smart Interlock Cable w / Water Tight Receptacle Plug - Only
<b>MEP801PC/30</b>	30' Smart Interlock Cable w / Water Tight Receptacle Plug - Only
<b>MEP801PCK/20</b>	Complete 20' Smart Interlock Cable Kit w /1 Relay / LED Power Indicator / Inline Fuse
<b>MEP801PCK/30</b>	Complete 30' Smart Interlock Cable Kit w /1 Relay / LED Power Indicator / Inline Fuse
<b>MEP802PCK/20</b>	Complete 20' Smart Interlock Cable Kit w /2 Relays / LED Power Indicator / Inline Fuse
<b>MEP802PCK/30</b>	Complete 30' Smart Interlock Cable Kit w /2 Relays / LED Power Indicator / Inline Fuse
<b>MEP803PCK/20</b>	Complete 20' Smart Interlock Cable Kit w /3Relays / LED Power Indicator / Inline Fuse
<b>MEP803PCK/30</b>	Complete 30' Smart Interlock Cable Kit w /3 Relays / LED Power Indicator / Inline Fuse



# ME217PIB / ME503PIB

## SMART INTERLOCK TECHNOLOGY ACME ADAPTER PROXIMITY INTERLOCK BRACKET INSTALLATION AND OPERATING INSTRUCTIONS

### Scope

The ME217PIB Proximity Interlock Bracket is designed for use with ME200 Series 1-3/4" Male Acme Adapters.  
The ME503PIB Proximity Interlock Bracket is designed for use with ME503-16 or ME252-16 3-1/4" Male Acme Adapter.

### Specifications

Supply Voltage: 10-30 VDC  
Max Current Draw: 200 MA (0.2A)  
Sensor Type: Normally Open  
Relay Type: Normally Open  
Fuse Rating: 1 AMP  
Temperature Limits: -20° F. to 160°F.

### Installation

**WARNING:** Failure to follow these instructions or to properly install and maintain this equipment could result in an explosion and/or fire causing property damage or personal injury or death. Marshall Excelsior Company equipment must be installed, operated and maintained in accordance with all federal, state and local codes and Marshall Excelsior instructions. The installation in most states must also comply with NFPA standards 58 and 59, and ANSI K61.1

Only personnel trained in the proper procedures, codes, standards and regulations of the LP-Gas and NH<sub>3</sub> industries should install, maintain, and service this equipment.

Be sure all instructions are read and understood before installation, operation and maintenance. These instructions must

**CAUTION:** Contact or inhalation of liquid propane, ammonia and their vapors can cause serious injury or death! NH<sub>3</sub> and LP-Gas must be released outdoors in the air currents that will insure dispersion to prevent exposure to people and livestock. LP-Gas must be kept far enough from any open flame or other source of ignition to prevent fire or explosion! LP-Gas is heavier than air and will not disperse or evaporate rapidly if released in still air.

**CAUTION:** The power supply in your system may produce energy hazards, which can cause bodily harm. To reduce the risk of electrical shock, a trained service technician must disconnect the power supply cables from the battery terminals before installation or service of the system.

**NOTE:** Before installing, inspect interlock assembly for shipping damage that may affect performance.

1. Remove mounting hardware from bracket as shown.

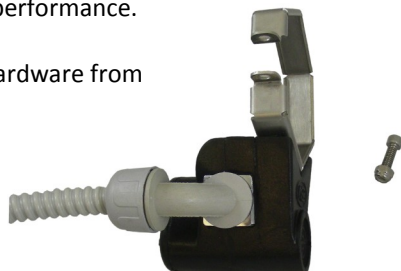

2. **ME217PIB:** Install ME217 Series Acme Adapter into ME825-10 Globe Valve as shown using a TPE Thread Sealant. Tighten Acme Adapter using appropriate wrench until adapter hex is lined up with installation hex on the valve as shown.

**ME503PIB:** Install ME503-16 Series Acme Adapter into ME825-16 Globe Valve as shown using a TPE thread sealant. Tighten Acme adapter using appropriate wrench until adapter hex is lined up with installation hex on valve as shown.



3. Spread Interlock Bracket Flanges over hex portion of Acme Adapter as shown

**NOTE:** Ensure sensor body is positioned below acme adapter and valve body as shown.



4. Tighten band around acme adapter and install mounting hardware through flange tabs as shown. Tighten mounting hardware using suitable wrench to secure interlock bracket to acme adapter.



## ME217PIB / ME503PIB

### SMART INTERLOCK TECHNOLOGY ACME ADAPTER PROXIMITY INTERLOCK BRACKET INSTALLATION AND OPERATING INSTRUCTIONS

5. **ME217PIB:** Install ME229FS Series Acme cap with flange onto ME217 Series 1-3/4" acme adapter as shown and tighten using MEP120B Spanner Wrench.

**ME503PIB:** Install ME441F8 Series Acme cap with flange onto ME503-16 Series 3-1/4" Acme adapter as shown and tighten using MEP120B Spanner Wrench.



**NOTE:** Gap between sensor body and acme cap flange should be less than .062" as shown.

If gap is greater than .062", sensor body may need to be adjusted forward to achieve proper sensing distance.

6. Route and Secure Conduit
- Determine where the conduit is to be routed and where it will pass through the deck or cabinet wall:
    - To pass sensor plug and conduit through deck or cabinet: drill a 1" to 1-1/16" diameter hole, route sensor cable thru hole and install grommet as shown.

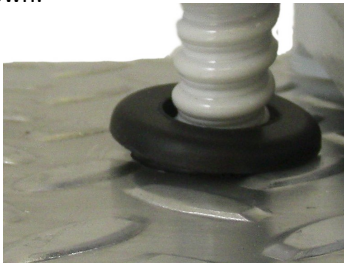

- Secure conduit to support surface approximately every six to eight inches with suitable conduit clamp or wire tie (not provided).

7. Connect Interlock to Allison Transmission "Auxiliary Function Range Inhibit"

**WARNING:**

- The positive (+) supply conductor of the interlock circuit **MUST** be protected by a fuse with a maximum rating of 1 Amp, as provided in the MEC Proximity Cable Kits.

**It must be replaced only with a fuse of the same rating.**

- The maximum current draw thru the sensor is 200 MA (0.2A).
- Ground connections must be made as indicated by vehicle manufacturers instructions.

- Connect the sensor cable plug to the mating connector on the 20' or 30' Single relay (MEP801PCK/20 or MEP801PCK/30), Dual relay (MEP802PCK/20 or MEP802PCK/30) or Universal (MEP801PC/20 or MEP801PC/30) Proximity Cable kit.
- Secure the connection in a protected location and route and secure all cables and wires using loom and wire ties or other suitable means
- Mount the sealed relay using the bracket provided, in either the engine compartment or cab, as desired.

**NOTE:** when mounting in the engine compartment, keep relay away from sources of heat and orient wires so they point down.
- Make the electrical connections as indicated on the wiring circuit diagrams included in this manual. For final connections to the Allison "Auxiliary Function Range Inhibit" circuit, follow the manufacturers instructions provided with the Allison transmission.

**NOTE:** Only trained personnel that are qualified to make connections to the Allison Transmission's range inhibit function, such as Allison Transmission certified technicians, should make these connections.
- Test the Proximity Interlock / Range Inhibit function for proper operation by installing the acme flange cap and the acme adapter and confirming that the red LED in the relay lights up indicating the circuit has been closed, and that the Range Inhibit interlock function allows Allison Transmission to shift out of park.

## Operation

When the acme flange cap is placed onto the acme adapter the sensor is actuated closing the sensor circuit. The sensor circuit interfaces with the auxiliary function range inhibit allowing the vehicle transmission to be shifted out of the park position.

**WARNING:** Never operate with a leaking valve. Failure to follow these instructions could result in an explosion and/or fire causing property damage or personal injury or death.



## ME217PIB / ME503PIB

### SMART INTERLOCK TECHNOLOGY ACME ADAPTER PROXIMITY INTERLOCK BRACKET INSTALLATION AND OPERATING INSTRUCTIONS

<b>Trouble Shooting</b>		
<b>Problem</b>	<b>Possible Cause</b>	<b>Recommended Action</b>
LED on relay does not light or relay does not activate	Relay not properly grounded	Mount the relay bracket to a grounded metallic surface or attach a ground strap between the relay bracket and an electrically grounded connection.
	Protective over-current fuse is blown	Replace the fuse <b>ONLY</b> with a fuse of an identical 1 AMP rating
	No power to sensor	Remove cover on sensor housing to verify green light on Turck® sensor, if no light then: <ul style="list-style-type: none"> <li>• Check fuse</li> <li>• Check for 12 volt with key on</li> <li>• Check ground wire from sensor</li> </ul>
LED on relay does not light or relay does not activate	No signal from sensor	Remove cover on sensor housing with acme flange cap installed on acme adapter verify change light on Turck® sensor. If no light then: <ul style="list-style-type: none"> <li>• Sensor needs to be replaced</li> </ul>
	Wiring—Incorrect or damaged	<ul style="list-style-type: none"> <li>• Check for 12 volts at pin 1 of sensor plug with key on</li> <li>• Check for 12 volts at pin 2 with acme flange cap installed on acme adapter and key on</li> <li>• Check for continuity between pin 3 and (-) negative terminal of battery</li> <li>• Check for continuity between relay black wire and (-) negative terminal of battery</li> <li>• Check for any loose crimps or damaged wires</li> <li>• Check for corrosion at all wiring connection points</li> </ul>
	Faulty relay	Replace relay
LED on, relay is on but truck will not shift out of park	Faulty Relay	Replace relay
	Wiring incorrect or damaged	<ul style="list-style-type: none"> <li>• Verify connections to and from the TCM of the transmission</li> <li>• Check for any loose crimps or damaged wires.</li> <li>• Check for corrosion at all wiring connections</li> </ul>
Connections test OK but interlock still does not function properly	Damaged or defective proximity sensor, sensor cable or sensor connector pins	Disconnect sensor connector and connect test jumper in its place. If interlock functions properly with test jumper but not with sensor, sensor must be repaired or replaced.

## Maintenance

**To ensure proper operation, perform the following maintenance:**

1. Check that all fasteners are tight at least monthly. Tighten any that are found to be loose.
2. Check sensor relay for proper operation as indicated by red LED light on relay.



# ME217PIB / ME503PIB WIRING DIAGRAM

## PROXIMITY INTERLOCK KIT

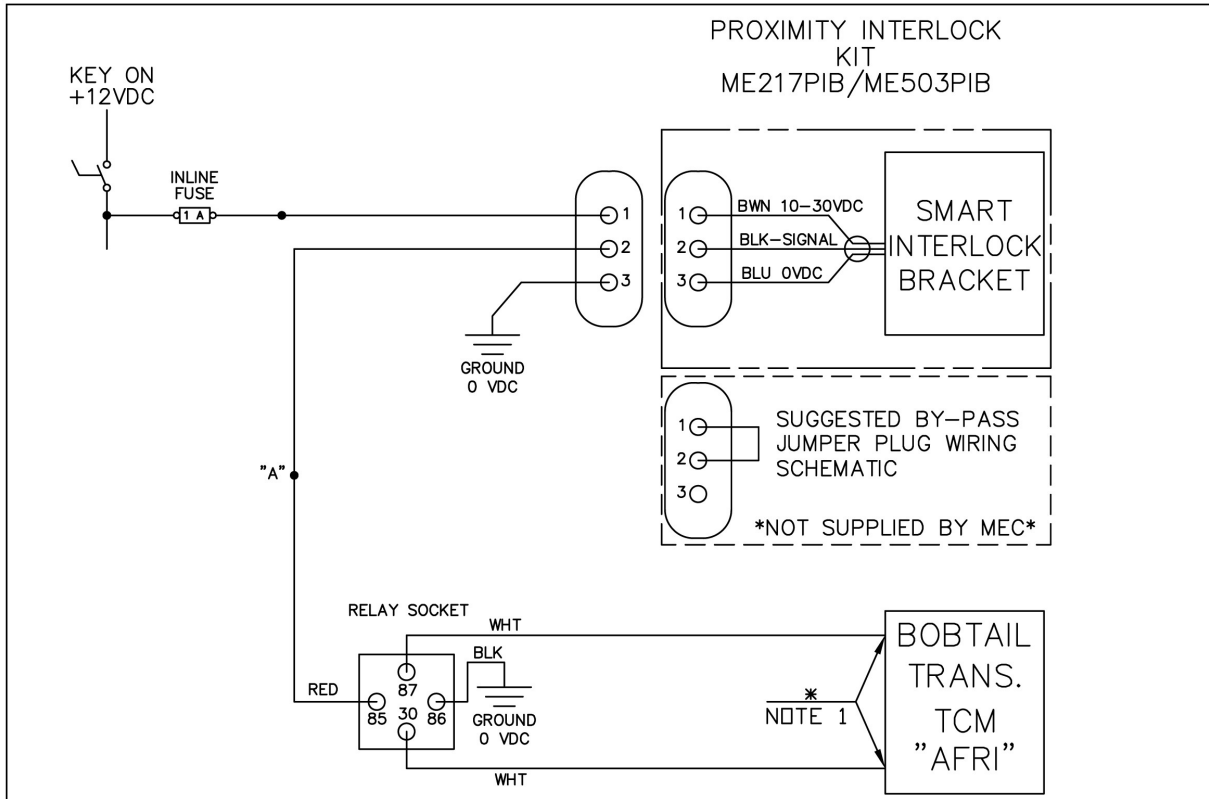

### MEC SUGGESTED WIRING

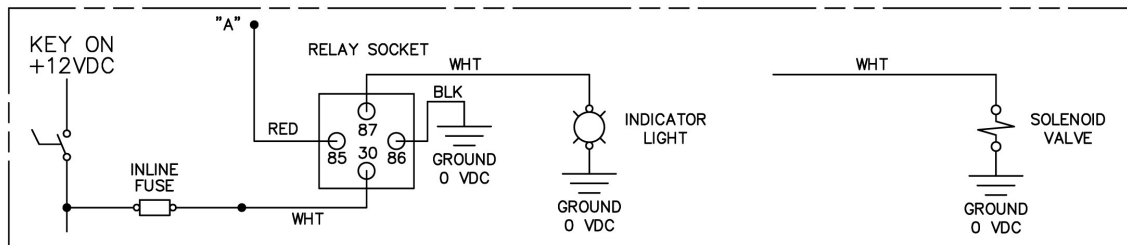

### OPTIONAL WIRING

**NOTES:**

1. CONNECT TO TRANSMISSION PER THE "AUXILIARY FUNCTION RANGE INHIBIT CIRCUIT" OF THE TRANSMISSION TCM.

WARNING – MAX CURRENT DRAW THRU THE ME217/503PIB SENSOR IS 200ma.

**MARSHALL EXCELSIOR CO.**

DRAWN az	NAME ME217/503PIB WIRING DIAGRAM	PAGE	DRAWING NO.
DATE 5/22/09	PROXIMITY INTERLOCK KIT	1-1	ME503PIB-WD



# MEP801PCK WIRING DIAGRAM

## SINGLE RELAY PROXIMITY CABLE KIT

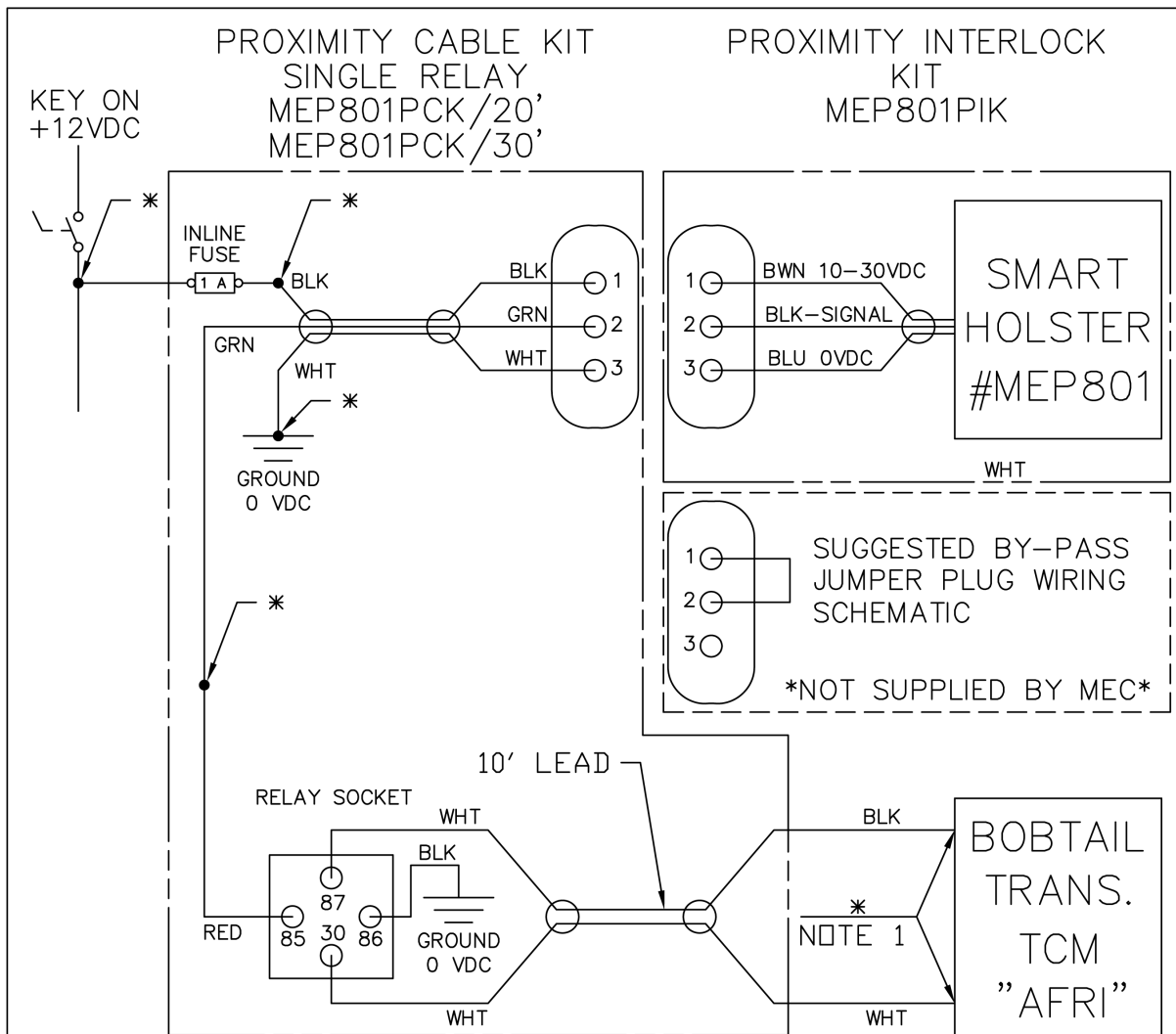

**NOTES:**

1. CONNECT TO TRANSMISSION PER THE "AUXILIARY FUNCTION RANGE INHIBIT CIRCUIT" OF THE TRANSMISSION TCM.

\* CUSTOMER CONNECTIONS.

**MARSHALL EXCELSIOR CO.**

DRAWN az	NAME MEP801PCK WIRING DIAGRAM	PAGE	DRAWING NO.
DATE 1/22/09	SINGLE RELAY PROXIMITY CABLE KIT	1-1	MEP801PCK-WD



# MEP802PCK WIRING DIAGRAM

## DUAL RELAY PROXIMITY CABLE KIT

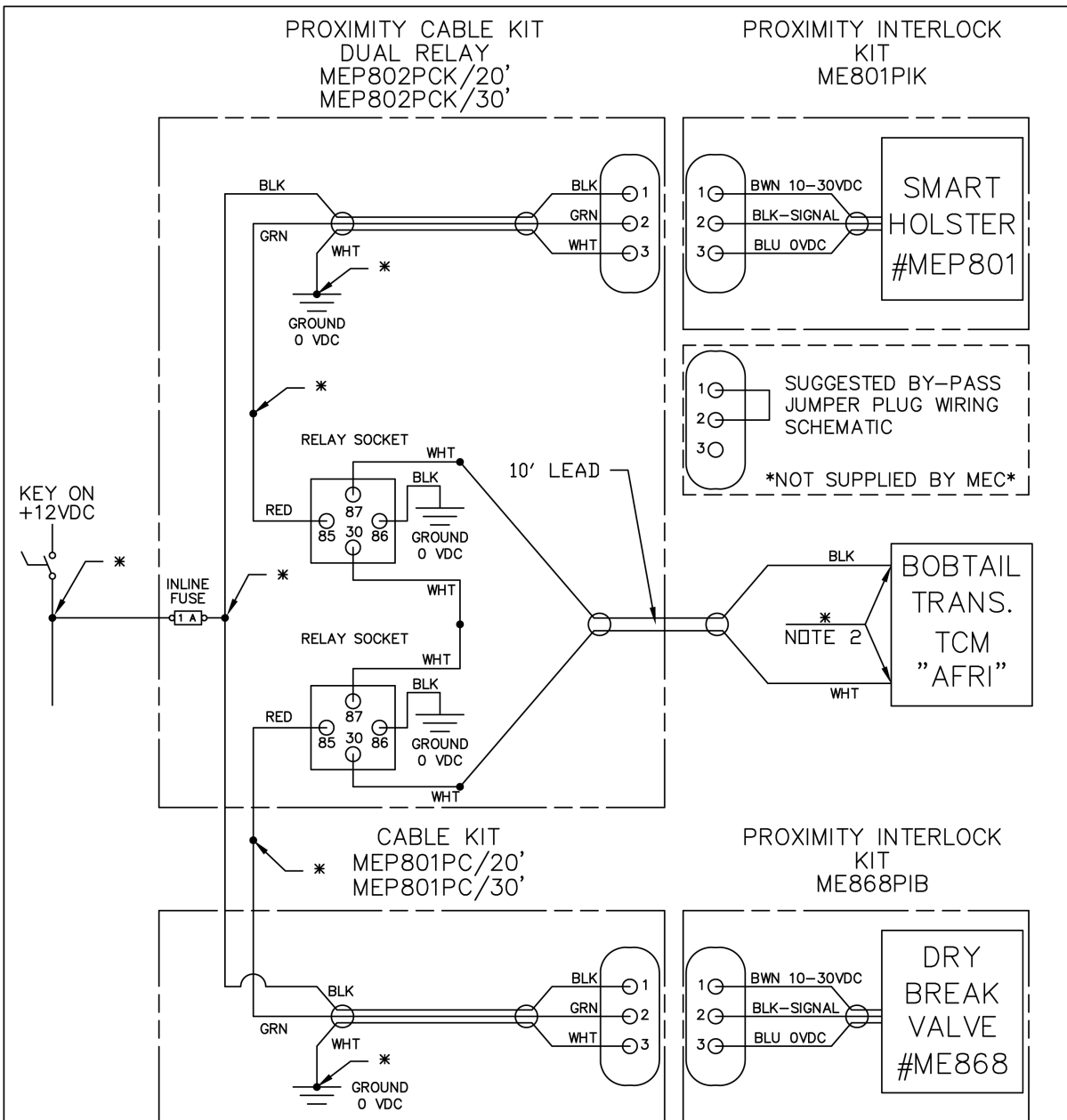

**NOTES:**

- 1. CONNECT TO TRANSMISSION PER THE "AUXILIARY FUNCTION RANGE INHIBIT CIRCUIT" OF THE TRANSMISSION TCM.
- \* CUSTOMER CONNECTIONS.

**MARSHALL EXCELSIOR CO.**

DRAWN az	NAME MEP802PCK WIRING DIAGRAM	PAGE	DRAWING NO.
DATE 1/22/09	DUAL RELAY PROXIMITY CABLE KIT	1-1	MEP802PCK-WD



# MEP801PC WIRING DIAGRAM

## PROXIMITY CABLE KIT

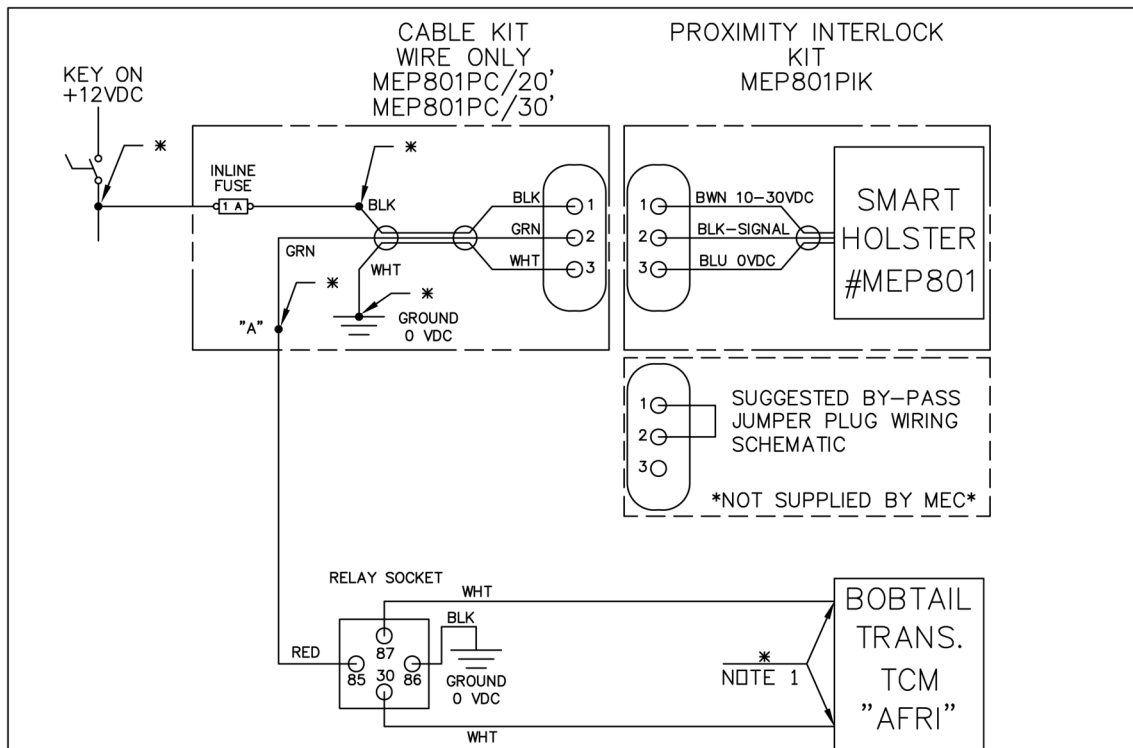

### MEC SUGGESTED WIRING

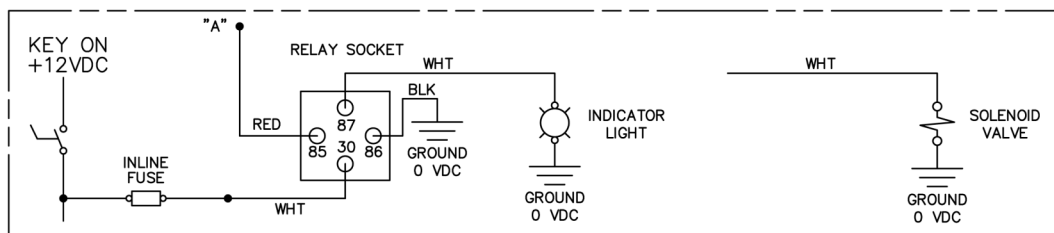

### OPTIONAL WIRING

#### NOTES:

1. CONNECT TO TRANSMISSION PER THE "AUXILIARY FUNCTION RANGE INHIBIT CIRCUIT" OF THE TRANSMISSION TCM.

WARNING – MAX CURRENT DRAW THRU THE MEP801PIK SENSOR IS 200ma.

\* CUSTOMER CONNECTIONS.

### MARSHALL EXCELSIOR CO.

DRAWN az	NAME MEP801PC WIRING DIAGRAM	PAGE	DRAWING NO.
DATE 1/22/09	PROXIMITY CABLE KIT	1-1	MEP801PC-WD

### Marshall Excelsior Company

1506 George Brown Drive Marshall, MI 49068

Phone (269) 789-6700 Fax (269) 781-8340

www.marshallexcelsior.com