



ME200B / ME200BK / ME200PIB / ME200PIBK

SMART INTERLOCK TECHNOLOGY

CHOCK BLOCK HOLSTER INSTALLATION AND OPERATING INSTRUCTIONS

Application:

Designed to provide a durable and convenient receptacle to store chock block during over-the-road transit. This holster can be mounted to truck fender or frame. Optional  Smart Interlock Technology is available for direct connection to Allison[®] automatic transmissions through the "auxiliary function range inhibit" or braking systems for manual transmission vehicles and to lock out pump operation.



 Smart Interlock Technology prevents the vehicle from being operated while the chock blocks are in use. This revolutionary system incorporates the industry's best and most durable sensor - Turck[®] - which is backed with a lifetime product warranty.



ME200PIBK

Features:

- All aluminum & stainless steel construction
- Holster handle reversible for left or right mount
- Supplied with all mounting hardware
- Available with optional  Smart Interlock Technology
 - Interlock Technology features "potted" Turck[®] proximity switch for maximum weather resistance and security against vibration
 - Supplied with water tight conduit & necessary wiring hardware to reach 4-1/2' with water tight receptacle plug
 - Optional wiring harness cable kits available in 20' or 30' lengths

Part #	Description
ME200B	Chock Block Holster
ME200PIB	Chock Block Holster with  Smart Interlock Technology
ME200BK	Chock Block Holster Kit with (2) ME200 Chock Blocks
ME200PIBK	Chock Block Holster Kit with  Smart Interlock Technology & (2) ME200 Chock Blocks
Accessories	
Part #	Description
ME200EXT	3" Standoff Extension Kit for Chock Block Holder
MEP801PC/20	20' Smart Interlock Cable w/ Water Tight Receptacle Plug - Only
MEP801PC/30	30' Smart Interlock Cable w/ Water Tight Receptacle Plug - Only
MEP801PCK/20	Complete 20' Smart Interlock Cable Kit w/ 1 Relay / LED Power Indicator / Inline Fuse
MEP801PCK/30	Complete 30' Smart Interlock Cable Kit w/ 1 Relay / LED Power Indicator / Inline Fuse
MEP802PCK/20	Complete 20' Smart Interlock Cable Kit w/ 2 Relays / LED Power Indicator / Inline Fuse
MEP802PCK/30	Complete 30' Smart Interlock Cable Kit w/ 2 Relays / LED Power Indicator / Inline Fuse
MEP803PCK/20	Complete 20' Smart Interlock Cable Kit w/ 3 Relays / LED Power Indicator / Inline Fuse
MEP803PCK/30	Complete 30' Smart Interlock Cable Kit w/ 3 Relays / LED Power Indicator / Inline Fuse
Replacement Parts	
Part #	Description
ME200B-104	Replacement Urethane Housing - Black



ME200B / ME200BK / ME200PIB / ME200PIBK

CHOCK BLOCK HOLSTER INSTALLATION AND OPERATING INSTRUCTIONS

Scope

The Chock Block Holster is available with the proximity sensor (ME200PIB /ME200PIBK) or without sensor (ME200B / ME200BK).

Specifications

Supply Voltage: 10-30 VDC
Max Current Draw: 200 MA (0.2A)
Sensor Type: Normally Open
Relay Type: Normally Open
Fuse Rating: 1 AMP
Temperature Limits: -20° F. to 160°F. (ME200PIB/ ME200PIBK)

Installation

WARNING: Failure to follow these instructions or to properly install and maintain this equipment could result in an explosion and/or fire causing property damage or personal injury or death. Marshall Excelsior Company equipment must be installed, operated and maintained in accordance with all federal, state and local codes and Marshall Excelsior instructions. The installation in most states must also comply with NFPA standards 58 and 59, and ANSI K61.1

Only personnel trained in the proper procedures, codes, standards and regulations of the LP-Gas and NH₃ industries should install, maintain, and service this equipment.

Be sure all instructions are read and understood before installation, operation and maintenance. These instructions must be passed along to the end user of the product.

CAUTION: The power supply in your system may produce energy hazards, which can cause bodily harm. To reduce the risk of electrical shock, a trained service technician must disconnect the power supply cables from the battery terminals before installation or service of the system.

CAUTION: Contact or inhalation of liquid propane, ammonia and their vapors can cause serious injury or death! NH₃ and LP-Gas must be released outdoors in the air currents that will insure dispersion to prevent exposure to people and livestock. LP-Gas must be kept far enough from any open flame or other source of ignition to prevent fire or explosion! LP-Gas is heavier than air and will not disperse or evaporate rapidly if released in still air.

NOTE: Before installing, inspect holster and interlock assemblies for shipping damage that may affect performance

- Determine the location where the holster is to be installed and check for obstructions on both sides of the mounting surface.
 - Using the mounting bracket as a template, mark the holes to be made in the mounting surface.
 - Drill the (4) mounting holes using a $\varnothing 7/16"$ to $\varnothing 1/2"$ drill.
- Install the (4) Nylon insulating spacers between the holster and the mounting surface and install holster bracket over holes in mounting surface.
- Install the (4) mounting bolts through holster bracket, nylon insulating spacers and mounting surface.
- Install (4) mounting washers and (4) locking nuts and tighten securely.

ME200PIB / ME200PIBK ONLY Proximity Interlock Holster

- Route and Secure Conduit
 - Determine where the conduit is to be routed and where it will pass through the fender or frame:
 - To pass sensor plug and conduit through fender: drill a 1" to 1-1/16" diameter hole, route sensor cable thru hole and install grommet as shown.



- Connect Interlock to Allison Transmission "Auxiliary Function Range Inhibit".

WARNING:

- The positive (+) supply conductor of the interlock circuit **MUST** be protected by a fuse with a maximum rating of 1 AMP, as provided in the MEC Proximity Cable Kits.
It must be replaced only with a fuse of the same rating.
- The maximum current draw thru the ME200PIB/ PIBK sensor is 200 MA (0.2A).
- Ground connections must be made as indicated by vehicle manufacturers instructions.

- Connect the sensor cable plug to the mating connector on the 20' or 30' Single relay (MEP801PCK/20 or MEP801PCK/30), Dual relay (MEP802PCK/20 or MEP802PCK/30) or Universal (MEP801PC/20 or MEP801PC/30) Proximity Cable kit.
- Secure the connection in a protected location and route and secure all cables and wires using loom and wire ties or other suitable means.
- Mount the sealed relay using the bracket provided, in either the engine compartment or cab, as desired. Note: when mounting in the engine compartment, keep relay away from sources of heat and orient wires so they point down.
- Make the electrical connections as indicated on the wiring circuit diagrams included in this manual.
For final connections to the Allison "Auxiliary Function Range Inhibit" circuit, follow the manufacturers instructions provided with the Allison transmission.
NOTE: Only trained personnel that are qualified to make connections to the Allison Transmission's range inhibit function, such as Allison Transmission certified technicians, should make these connections.
- Test the Proximity Interlock / Range Inhibit function for proper operation by moving the latch handle up and down and confirming that the red LED in the relay lights up indicating the circuit has been closed, and that the Range Inhibit interlock function allows Allison Transmission to shift out of park.

ME200B / ME200BK / ME200PIB / ME200PIBK

CHOCK BLOCK HOLSTER INSTALLATION AND OPERATING INSTRUCTIONS

Operation

When the chock block handle is in the locked (up) position, the sensor is actuated closing the sensor circuit. The sensor circuit interfaces with the auxiliary function range inhibit allowing the vehicle transmission to be shifted out of the park position. When connected to interlock pump, the pump will function when the handle is in the unlocked (down) position.

Trouble Shooting		
Problem	Possible Cause	Recommended Action
LED on relay does not light or relay does not activate	Relay not properly grounded	Mount the relay bracket to a grounded metallic surface or attach a ground strap between the relay bracket and an electricity grounded connection
	Protective over-current fuse is blown	Replace the fuse ONLY with a fuse of an identical 1 AMP rating
	No Power to sensor	Remove cover on sensor housing to verify green light on Turck sensor, if no light then: <ul style="list-style-type: none"> • Check fuse • Check for 12 volt with key on • Check ground wire from sensor
	No signal from sensor	Remove sensor housing, with sensor paddle pushed in verify change light on Turck® sensor. If no light then: <ul style="list-style-type: none"> • Sensor needs to be replaced • Paddle needs replaced
	Wiring—Incorrect or damaged	<ul style="list-style-type: none"> • Check for 12 volts at pin 1 of sensor plug with key on • Check for 12 volts at pin 2 with handle up and key on • Check for continuity between pin 3 and (-) negative terminal of battery • Check for continuity between relay black wire and (-) negative terminal of battery • Check for any loose crimps or damaged wires • Check for corrosion at all wiring connection points
LED on, relay is on but truck will not shift out of park	Faulty relay	Replace relay
	Faulty relay	Replace relay
	Wiring incorrect or damaged	<ul style="list-style-type: none"> • Verify connections to and from the TCM of the transmission • Check for any loose crimps or damaged wires. • Check for corrosion at all wiring connections
Connections test OK but interlock still does not function properly	Damaged or defective proximity sensor, sensor cable or sensor connector pins	Disconnect sensor connector and connect test jumper in its place. If interlock functions properly with test jumper but not with sensor, sensor must be repaired or replaced.

Maintenance

To ensure proper operation, perform the following maintenance:

1. Check that the holster handle moves freely before each use. Repair or replace interlock if it is not functioning properly.
2. Check that all fasteners are tight at least monthly. Tighten any that are found to be loose.
3. Check sensor relay for proper operation as indicated by red LED light on relay.

ME200PIB/PIBK WIRING DIAGRAM

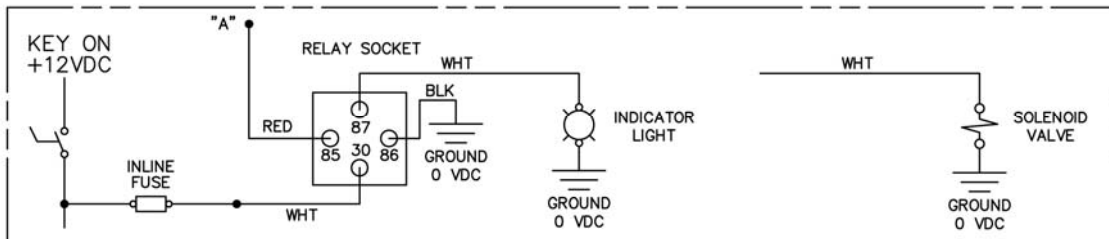
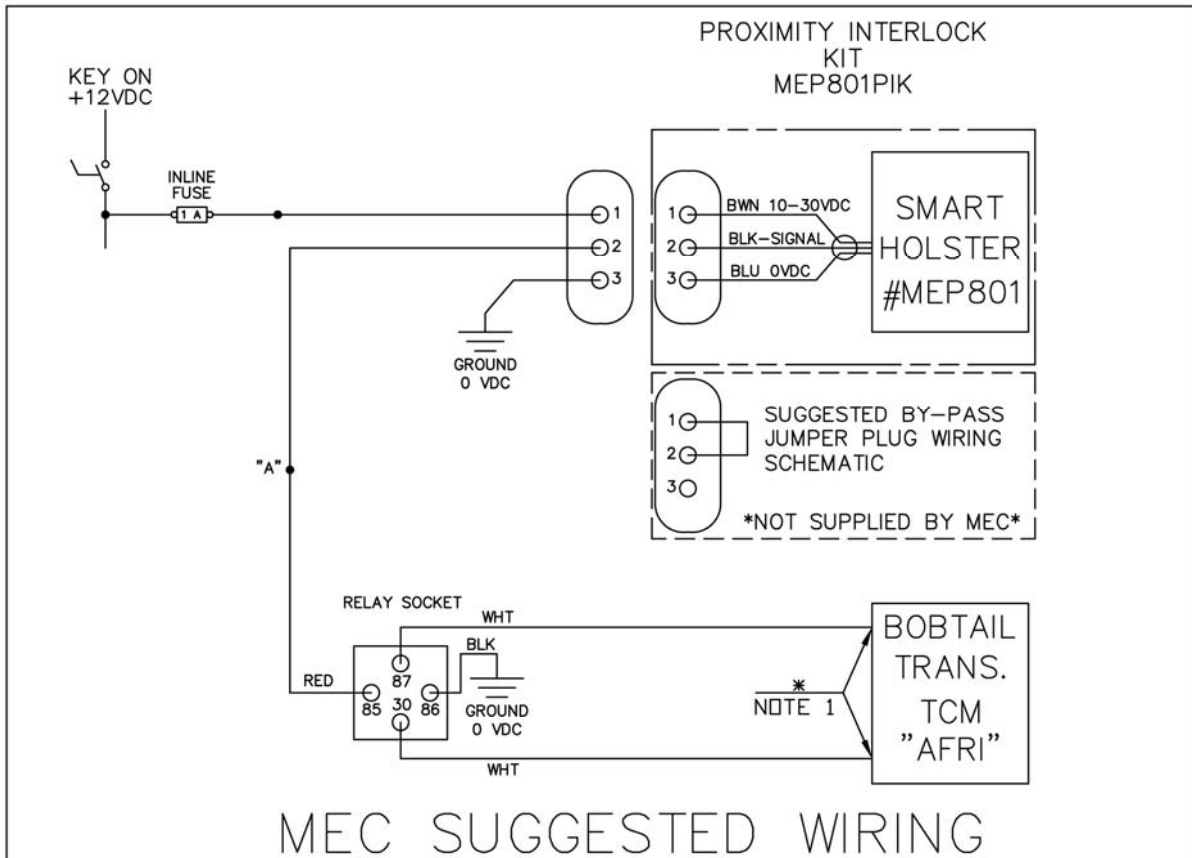

NOTES:

1. CONNECT TO TRANSMISSION PER THE "AUXILIARY FUNCTION RANGE INHIBIT CIRCUIT" OF THE TRANSMISSION TCM.

WARNING – MAX CURRENT DRAW THRU THE MEP801PIK SENSOR IS 200ma.

MARSHALL EXCELSIOR CO.

DRAWN az	NAME MEP801PIK WIRING DIAGRAM	PAGE	DRAWING NO.
DATE 1/22/09	PROXIMITY INTERLOCK KIT	1-1	MEP801PIK-WD



ME200PIB/PIBK WIRING DIAGRAM

SINGLE RELAY PROXIMITY CABLE KIT

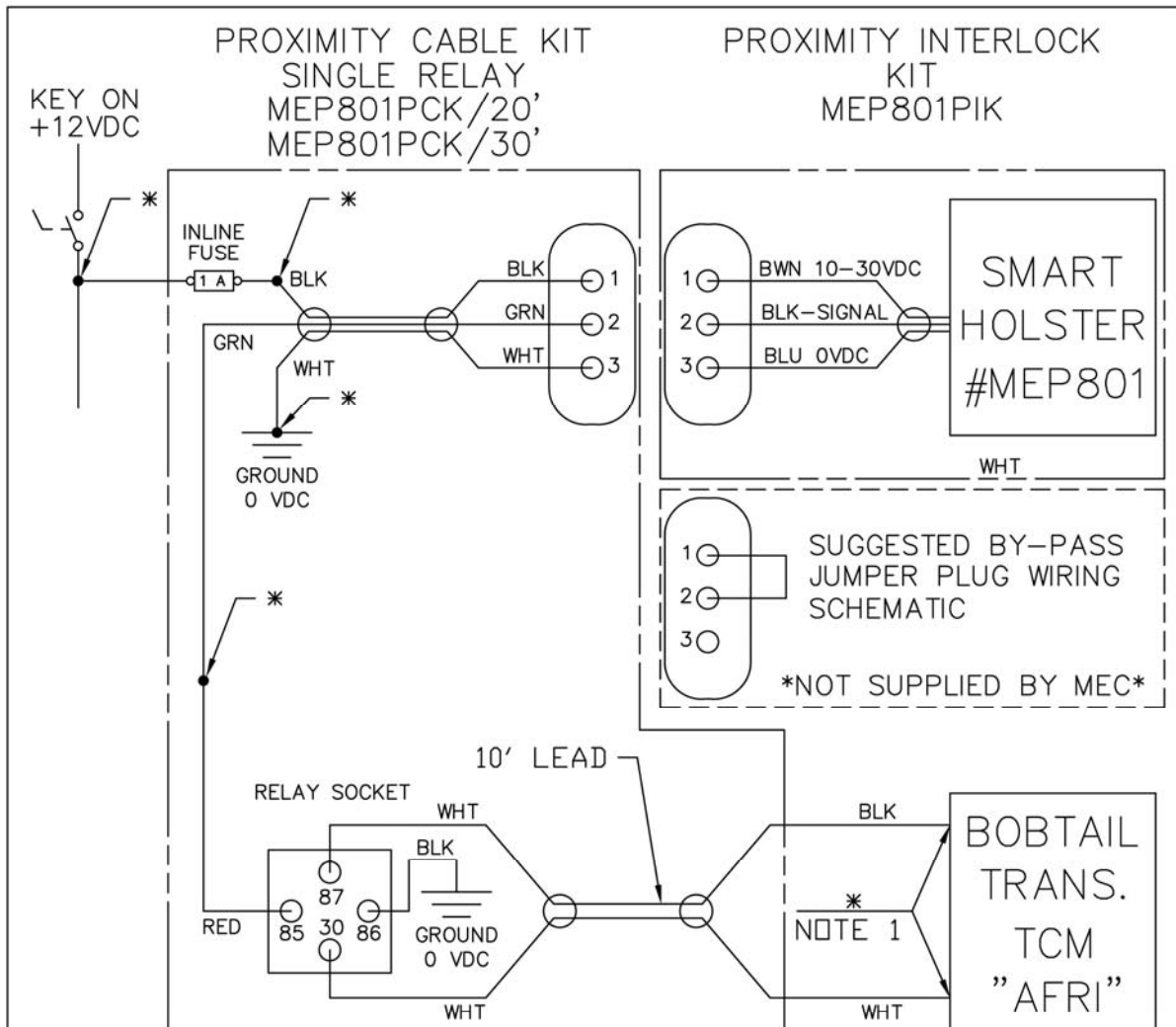

NOTES:

1. CONNECT TO TRANSMISSION PER THE "AUXILIARY FUNCTION RANGE INHIBIT CIRCUIT" OF THE TRANSMISSION TCM.

* CUSTOMER CONNECTIONS.

MARSHALL EXCELSIOR CO.

DRAWN az	NAME MEP801PCK WIRING DIAGRAM	PAGE	DRAWING NO.
DATE 1/22/09	SINGLE RELAY PROXIMITY CABLE KIT	1-1	MEP801PCK-WD



ME200PIB/PIBK WIRING DIAGRAM

DUAL RELAY PROXIMITY CABLE KIT

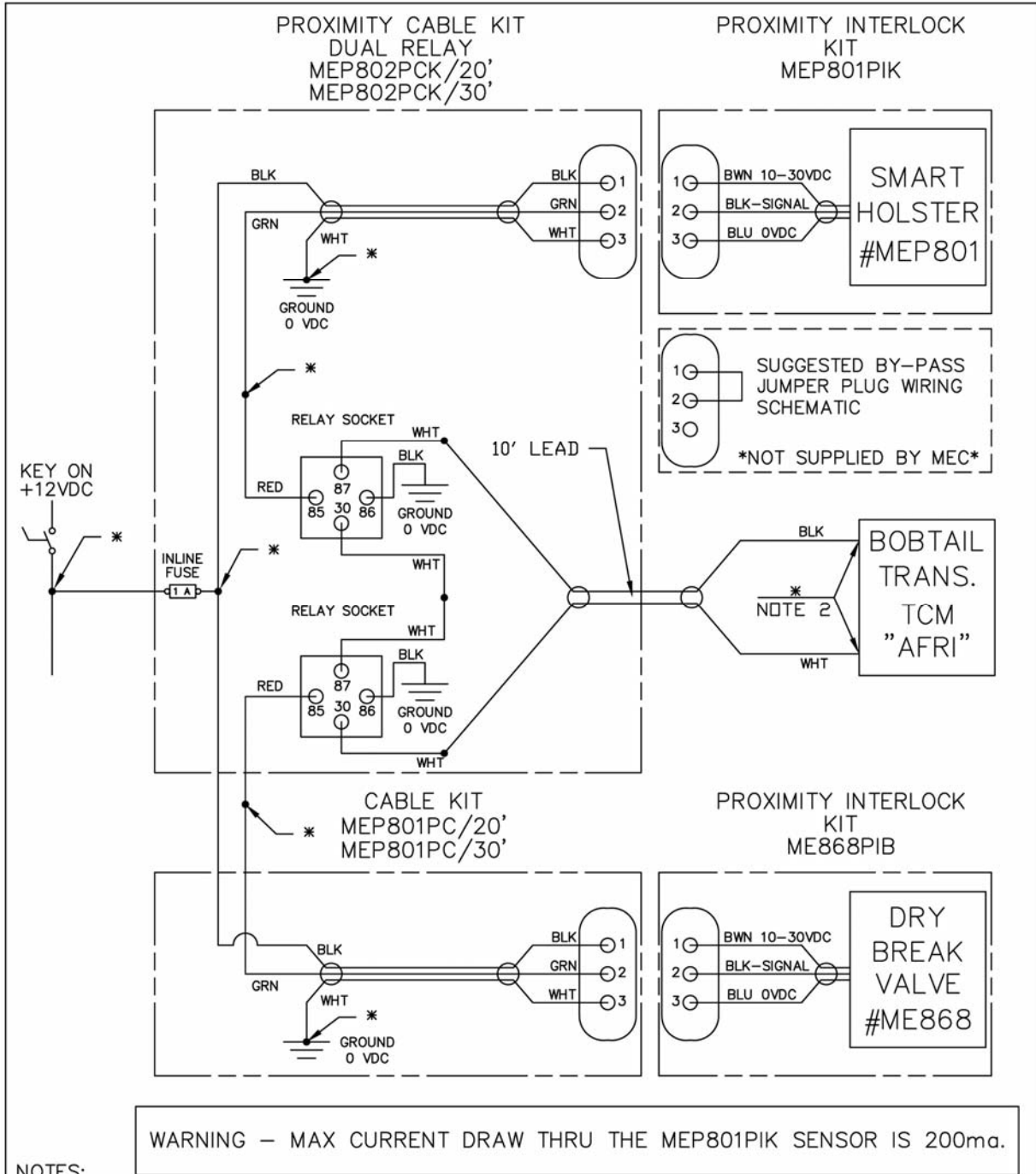

NOTES:

1. CONNECT TO TRANSMISSION PER THE "AUXILIARY FUNCTION RANGE INHIBIT CIRCUIT" OF THE TRANSMISSION TCM.
- * CUSTOMER CONNECTIONS.

MARSHALL EXCELSIOR CO.

DRAWN az	NAME MEP802PCK WIRING DIAGRAM	PAGE	DRAWING NO.
DATE 1/22/09	DUAL RELAY PROXIMITY CABLE KIT	1-1	MEP802PCK-WD



ME200PIB/PIBK WIRING DIAGRAM

PROXIMITY CABLE KIT

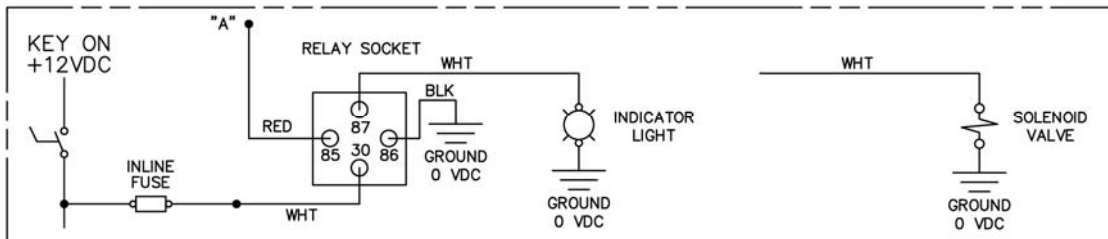
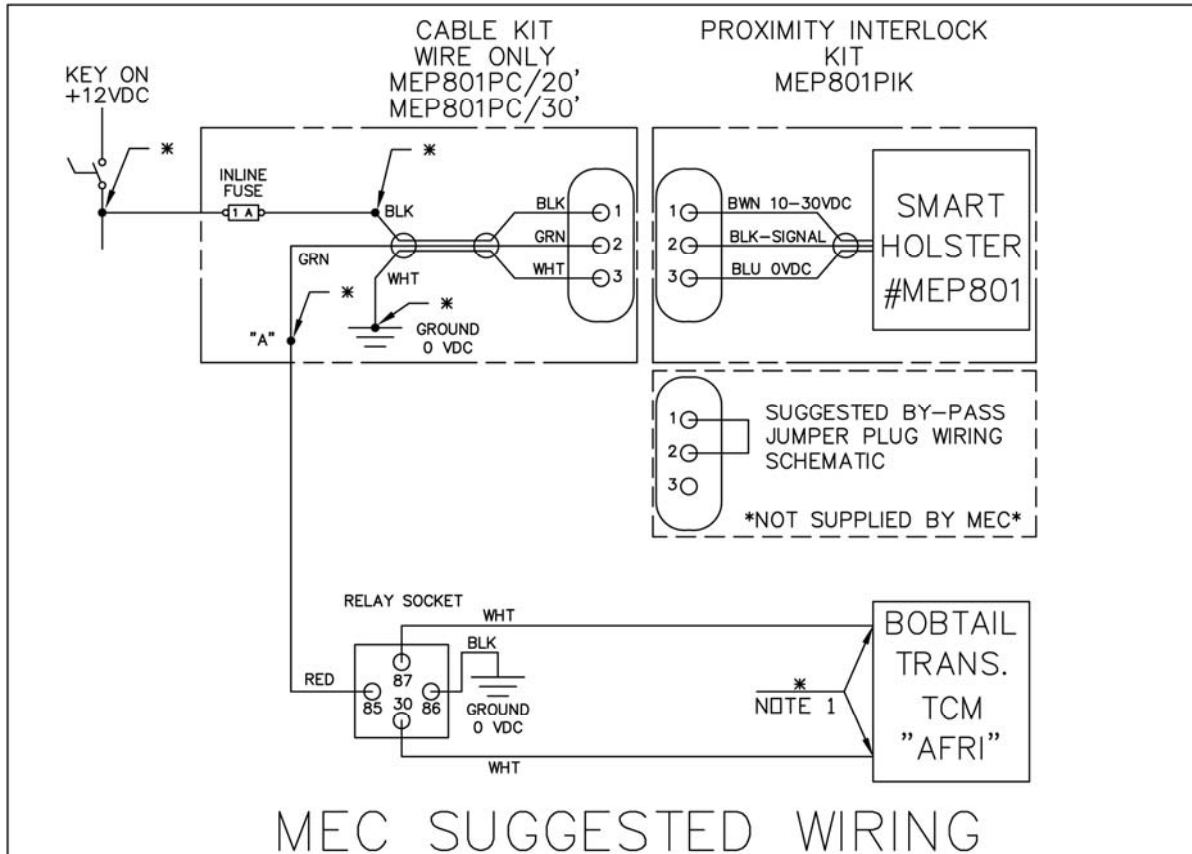

NOTES:

1. CONNECT TO TRANSMISSION PER THE "AUXILIARY FUNCTION RANGE INHIBIT CIRCUIT" OF THE TRANSMISSION TCM.

WARNING – MAX CURRENT DRAW THRU THE MEP801PIK SENSOR IS 200ma.

* CUSTOMER CONNECTIONS.

MARSHALL EXCELSIOR CO.

DRAWN AZ	NAME MEP801PC WIRING DIAGRAM	PAGE	DRAWING NO.
DATE 1/22/09	PROXIMITY CABLE KIT	1-1	MEP801PC-WD



Marshall Excelsior
—  —
Gas Connections

Marshall Excelsior Company
Ph: 269-789-6700, Fax 269-781-8340
E-mail: sales@marshallexcelsior.com
www.marshallexcelsior.com