



ISO 9001
Certified

...Innovative liquid vaporizing and gas mixing solutions

TORREXX

Vertical electric single core vaporizer

Operations & Maintenance Manual

151 South Michigan Street, Seattle, Washington, USA 98108

Tel: +1-206-789-5410 Fax: +1-206-789-5414 Web: www.algas-sdi.com

WARNING

Read the OPERATION MANUAL before operating this equipment.

- **NOTE:** Algas-SDI reserves the right to use alternate manufacturers' components as vendor delivery applicability dictates. Vendors have supplied literature contained in the Operation Manual. Please check to be sure supplied data matches your configuration. Contact Algas-SDI if any questions exist.
- This equipment uses LPG - a flammable fuel, handled under pressure. Inherent hazards exist and a thorough understanding of the equipment is required to allow safe operation and maintenance.
- Allow only a **TRAINED and FULLY QUALIFIED PERSON** to service this equipment.
- Any time a component must be replaced use the same type, model etc. **DO NOT SUBSTITUTE!** The consequence from such actions is unpredictable and may lead to dire consequences. When components are replaced with components not approved for use in our FM listed equipment, the FM listing becomes void for that unit.

WARRANTY REGISTRATION

To register your new equipment: Visit **Algas-SDI's** web site at: www.algas-sdi.com, then click on the "Tech Support" button. Select online Registration or print out the Acrobat Warranty Registration.

OR

Fill out the Warranty Registration information on the last page of this manual. Then make a photocopy and mail to the address shown at the bottom.

WARRANTY, COPYRIGHTS AND APPROVALS

WARRANTY

Algas-SDI International, LLC (**ASDI**) warrants that the equipment is free of defects in materials and workmanship under normal use and service. **ASDI** agrees to repair or replace, at our option, without charge f.o.b. factory, any part which has proven defective to the satisfaction of Algas-SDI International, LLC within one (1) year from the date of the original installation or within 18 months from the date of shipment, whichever is earlier. Equipment, which in the opinion of **ASDI**, has been damaged by improper installation or operation, or has been abused or tampered with in any way, will not be accepted for return under warranty.

Algas-SDI International, LLC will not accept back charges for work performed by others upon or in conjunction with **ASDI** equipment, unless prior authorization is given by means of an Algas-SDI International, LLC purchase order. Algas-SDI International, LLC will not be liable by reason of shutdown, non-operation or increased expense of operation of other equipment, or any other loss or damage of any nature, whether direct or consequential, arising from any cause whatsoever.

Algas-SDI International, LLC makes NO other warranty of any kind, whatsoever expressed or implied; and all warranties of merchantability and fitness for a particular purpose are hereby disclaimed by Algas-SDI International, LLC and excluded from these terms of sale. No person has any authority to bind Algas-SDI International, LLC to any representation or warranty other than this warranty.

COPYRIGHT

Copyright 2013 by Algas-SDI International, LLC, Seattle, Washington 98108. All rights reserved. No part of this manual may be reproduced or copied in any form or by any means, photographic, electronic, or mechanical, without the prior express written consent from Algas-SDI International, LLC, Seattle, Washington, USA.

APPROVALS



*Approvals depending on model

SYMBOLS AND CONVENTIONS

Special symbols are used to denote hazardous or important information. You should familiarize yourself with their meaning and take special notice of the indicated information. Please read the following explanations thoroughly.

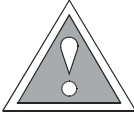

GENERAL WARNING OR CAUTION

This symbol indicates hazards or unsafe practices, which can result in damage to the equipment or cause personal injury. Use care and follow the instructions given.



FLAMMABLE GAS HAZARD

This symbol indicates a potential hazard, which can result in severe personal injury or death. Use extreme care and follow the instructions given.



ELECTRICAL DISCONNECT REQUIRED

This symbol indicates a potentially dangerous situation, which can result in severe personal injury or death or damage to equipment. Use great care and follow the instructions given.

ASDI CONTACT NUMBERS

If you have questions, need help with your equipment, or want information on other products, contact Algas-SDI at:

Telephone: 206.789.5410

Facsimile: 206.789.5414

Email: sales@algas-sdi.com

Internet: <http://www.algas-sdi.com>

TORREXX TABLE of CONTENTS

1. INTRODUCTION

DESCRIPTION	1-1
<i>Figure 1 – TORREXX Dimensional Drawing (LPG Version)</i>	1-2
TORREXX OPTIONS – INTRODUCTION	1-3

2. MAJOR COMPONENTS

DESCRIPTION	2-5
<i>Figure 2 – Heating system</i>	2-5
<i>Figure 3 – Liquid Passage Prevention system</i>	2-6
MAJOR COMPONENTS LIST	2-7
<i>Figure 4 – TORREXX Major Components Drawing (LPG CONFIGURATION)</i>	2-7

3. INSTALLATION

GENERAL	3-8
<i>Figure 5 – Typical TORREXX Installation Drawing with Pump & Vapor Bypass</i>	3-8
<i>Figure 6 – Typical TORREXX Installation Drawing with Vapor Bypass and No Pump</i>	3-9
<i>Figure 7 – Typical TORREXX Installation Drawing with Economy Operation and Vapor Bypass</i>	3-9
<i>Figure 8 – Typical TORREXX Installation Drawing for Manifolding 2 Vaporizers</i>	3-10
<i>Figure 9 – Typical TORREXX Installation Drawing for Manifolding 3 Vaporizers</i>	3-10
LIQUID LINE	3-11
LIQUID PUMP	3-11
VAPOR LINE	3-11
SAFETY RELIEF VALVE	3-12
ELECTRICAL SERVICE	3-12
DETERMINING WIRE SIZE	3-12
<i>Table 1 – Wire Length Chart (#4 AWG)</i>	3-13
<i>Table 2 – Wire Length Chart (#6 AWG)</i>	3-13
<i>Table 3 – Wire Length Chart (#8 AWG)</i>	3-14
<i>Table 4 – Wire Length Chart (#10 AWG)</i>	3-14
<i>Table 5 – Liquid Temperature vs. Tank Pressure Chart</i>	3-15
<i>Table 6 – LPG liquid line sizing chart (Minimum Pipe Size)</i>	3-16
<i>Table 7 – Equivalent Pipe Length of Various Valves and Fittings (Length in Feet/Meters)</i>	3-16

TORREXX TABLE of CONTENTS - Continued

4. OPERATION

GENERAL	4-17
OPERATING INSTRUCTIONS	4-17
STARTING THE VAPORIZER	4-18
STOPPING THE VAPORIZER	4-18
PURGING THE VAPORIZER	4-18

5. MAINTENANCE

GENERAL	5-20
CONTACTOR INSPECTION	5-21
Liqui-SAFE™ VALVE – PERFORMANCE CHECK (6 MONTHS)	5-22
<i>Figure 10 – Steps to check the Liqui-SAFE™ valve operation</i>	5-22
Liqui-SAFE™ VALVE – SERVICE INSTRUCTIONS	5-23
<i>Figure 11A – STEP 1 – Be sure that the Liqui-SAFE™ valve is at the close position as shown</i>	5-23
<i>Figure 11B – STEP 2 – Unscrew reset button base and remove spring</i>	5-23
<i>Figure 11C – STEP 3 – Replace button post internal o-ring</i>	5-24
<i>Figure 11D – Full hook o-ring tool</i>	5-24
<i>Figure 11E – STEP 4 – Unscrew valve latch body</i>	5-24
<i>Figure 11F – STEP 5 – Replace valve body static o-ring</i>	5-25
<i>Figure 11G – STEP 6 – Replace valve seat and valve stem base o-rings</i>	5-25

6. TROUBLESHOOTING

TROUBLESHOOTING TREES	6-26
TREE 0 – No flow out of the vaporizer	6-26
TREE 1A – Liqui-SAFE valve trips	6-27
TREE 2A – Liqui-SAFE valve does not trip	6-29
FULL LOAD VOLTAGE CHECK	6-31
<i>Figure 12 – Full load voltage check</i>	6-31
FULL LOAD CURRENT CHECK	6-32
<i>Figure 13 – Full Load Current Check</i>	6-32
TORREXX ELECTRIC VAPORIZER DATA SHEET	6-33
HEATER CORE RESISTANCE	6-34
<i>Figure 14 – Heater Core Resistance Wiring Connections</i>	6-34
SOLENOID VALVE LEAK TEST	6-35
<i>Figure 15 – Solenoid Valve Leak Test Components</i>	6-35

TORREXX TABLE of CONTENTS - Continued

SOLENOID VALVE ELECTRICAL TEST	6-36
<i>Figure 16 – Solenoid Valve Electrical Test</i>	6-36
THERMOCOUPLE SENSOR REPLACEMENT	6-37
<i>Figure 17 – TORREXX Box showing Thermocouple location</i>	6-37
<i>Figure 18 – Thermocouple Sensor with Bayonet Style Retainer</i>	6-38

7. TORREXX OPTIONS

ECONOMY OPERATION	7-39
<i>Figure 19 – TORREXX Economy valve installation</i>	7-39
TORREXX ECONOMY VALVE MAINTENANCE	7-40
<i>Figure 20A – STEP 1 – Unscrew the Inlet Housing from the Outlet Housing</i>	7-40
<i>Figure 20B – STEP 2 – Replace the two O-rings, apply excess o-ring grease.</i>	7-40
<i>Figure 20C – STEP 3 – Clean all o-ring contact surfaces and the bottom surface of the Outlet Housing. Apply excess o-ring grease</i>	7-41
<i>Figure 20D – STEP 4 – Clean all piston surfaces. Apply excess grease on o-rings</i>	7-41
<i>Figure 20E – STEP 5 – Make sure that the Pin Hole is clear and The Spring is undamaged. Carefully reassemble all the parts. Apply lubrication grease on straight threads if necessary</i>	7-41
MERCURY RELAY	7-42
TX REMOTE BOX	7-42
VALVE AND STRAINER PACKAGE	7-43
FILTAIRE – CONTAMINANT SEPARATOR	7-43
<i>Figure 21 – Filtaire Operation</i>	7-43

APPENDIX A – TECHNICAL INFORMATION

EC DECLARATION OF CONFORMITY
TORREXX LPG VAPORIZER DATA SHEET (FM)
TORREXX ELECTRIC VAPORIZER SPARE PARTS AND ACCESSORIES (FM)
<i>Figure 23 – TORREXX ELECTRIC VAPORIZER MAJOR COMPONENTS AND ACCESSORIES</i>
TORREXX LPG VAPORIZER DATA SHEET (NEMKO)
TORREXX ELECTRIC VAPORIZER SPARE PARTS AND ACCESSORIES (NEMKO)
HEATER BUSSING DIAGRAMS
EQUIPMENT DRAWINGS
INSTALLATION DRAWINGS
TORREXX WIRING SCHEMATIC
REMOTE BOX WIRING SCHEMATICS
SOLENOID NOISE
ASCO SOLENOID VALVE USED BY ASDI
SOLENOID VALVE INSTLLATION AND MAINTENANCE INSTRUCTIONS

Warranty Registration – Refer to the nameplate on the unit to fill out the product registration. Then photocopy and mail to address shown

DESCRIPTION

The dimensional drawing (see page 1-2) identifies various components of the **Algas-SDI TORREXX** vaporizer. Multiple resistance heating elements provide thermal energy to the finned aluminum heat exchanger. A solid state controller monitors the heat exchanger temperature and regulates the operating temperature to a predetermined set point. The controls consist of 2 individual K-type thermocouple sensors with independent high temperature limits. One sensor monitors operating temperature and the other controls the liquid inlet solenoid valve. The liquid inlet solenoid valve does not open until a predetermined warm-up temperature is reached. The vaporizer reaches operating temperature in approximately 60 seconds from a cold start. The vaporized LPG rises into the vapor header and exits through the vapor outlet. The Liqui-SAFE™ Valve is specially developed to prevent liquid from going downstream.

TORREXX Vaporizer can be configured for many applications.

- ◆ Standard configuration for Class I, Division 1, Group D for use with propane and LPG applications, FM and cFM approvals.
- ◆ Standard configuration for Zone I for use with propane and LPG, NEMKO & CE mark.
- ◆ Feedback configuration for Class I, Division 1, Group D for Propane and LPG for tank heater applications where adequate tank pressure must be maintained.
- ◆ TORREXX™ vaporizer can be manifolded together for increased capacity on a single skid. Consult Algas-SDI for Configuration information.
- ◆ TORREXX™ vaporizer can be packaged with an Algas-SDI mixing system on a single skid. Consult Algas-SDI for Configuration information.
- ◆ For customizing the TORREXX™ vaporizer to your requirements consult Algas-SDI for information.

Figure 1 – TORREXX Dimensional Drawing (LPG Version)

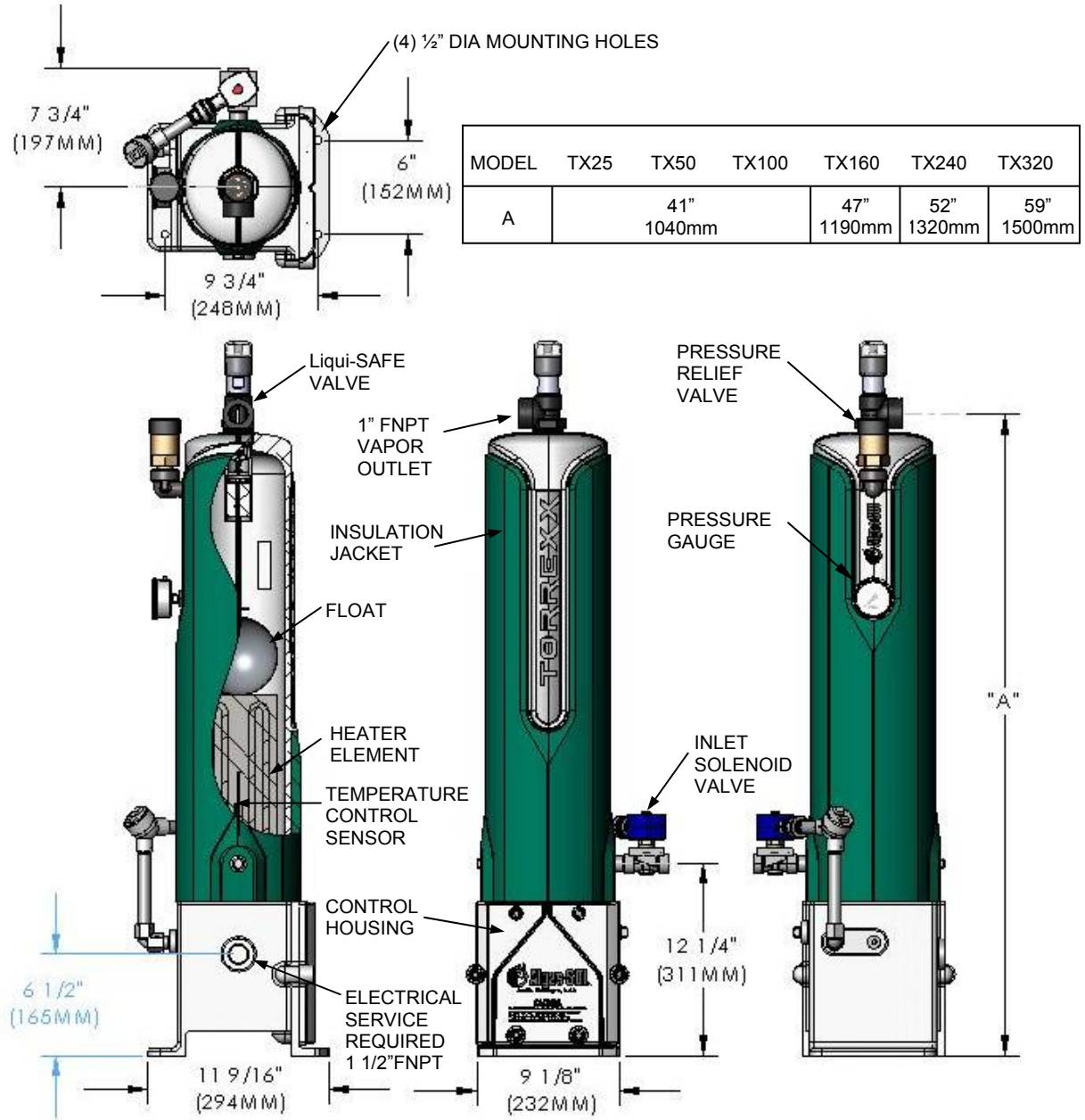

TORREXX VAPORIZER OPTIONS

Your TORREXX™ vaporizer may be equipped with one or several of the factory options. All the options can be integrated to your TORREXX™ vaporizer and are designed to enhance convenience for the end user.

Below is a brief introduction to the options available for the TORREXX™ vaporizer. See SECTION 8 of this manual or contact Algas-SDI for more information.

- 1) **Valve and Strainer Package** – Includes strainer with magnetic plug, inlet shut-off angle valve, hydrostatic relief valve, outlet shut-off ball valve and outlet pressure gauge. Ships loose. All items not shown below.

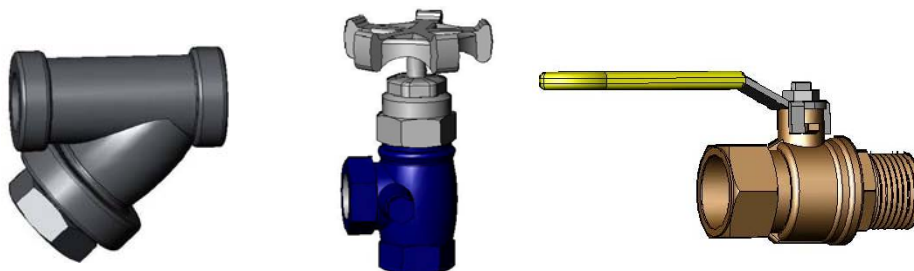

- 2) **Pipe Away Adapter** – Allows the user to pipe the relief valve away from the vaporizer. Fits relief valve P/N 34876. 1" FNPT pipe connection.

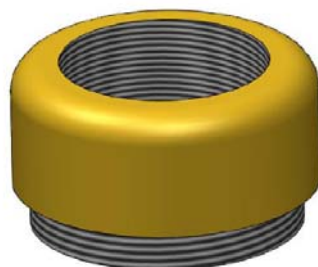

- 3) **TORREXX Stand** – Elevates TORREXX Vaporizer 1 foot off the ground for ease of control box access and removes the vaporizer from elements i.e. snow and mud. Hardware to mount TX to stand is included. Ships loose.

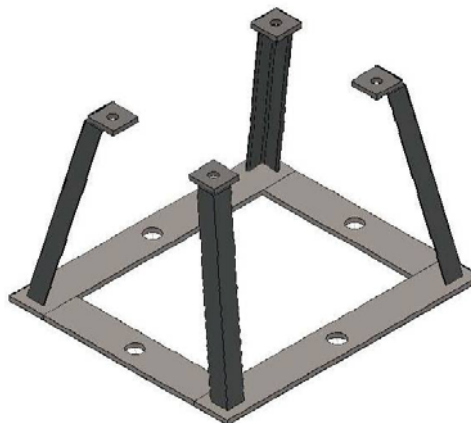

- 4) **Economy** – Allows the customer to use propane storage tank vaporization when the storage tank can provide enough vaporization and pressure to satisfy the load requirements.

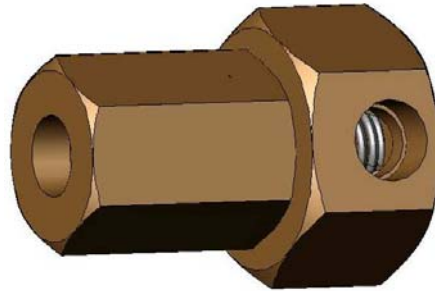

- 5) **Remote Control** – Includes remote start/stop capability and a status light indicating the vaporizer is ready for operation (solenoid valve open). IP65 (NEMA 4) enclosure.

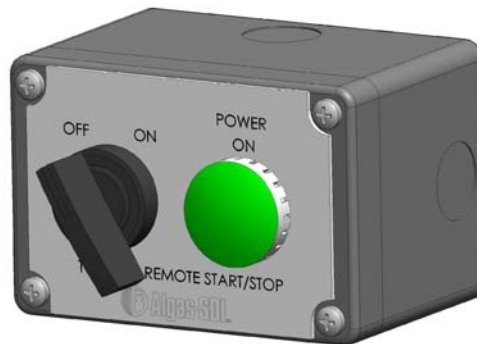

- 6) **Drain valve kit** – Enables the user to drain the oils, heavy ends, and other impurities that can collect over time in the vaporizer heat exchanger. Kit available factory or field installed.

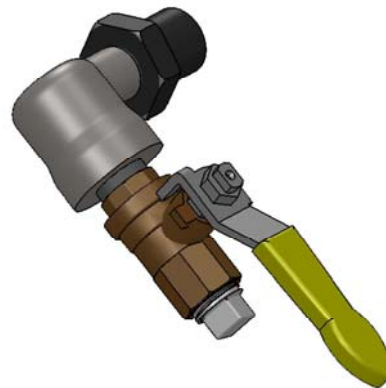

- 7) **Stabilaire Pump Package** – Consult factory
- 8) **Contaminant Separator (Filtaire)** – The Algas-SDI Filtaire™ is a filtering device design to trap heavy hydrocarbons commonly present in LPG gas vapor. It also traps other materials, which may be in gas due to storage conditions and internal condition of the equipment.
- 9) **Balancing orifice** – When manifolding two or more vaporizer together a balancing orifice must be used.

SAFETY

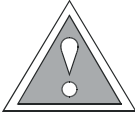

CAUTION

Propane Odor can fade.

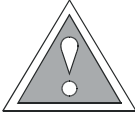

CAUTION

Vaporizer may be hot after or during use.

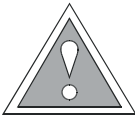

CAUTION

*Allow only a **TRAINED and FULLY QUALIFIED PERSON** to service this equipment.*

MAJOR COMPONENTS

2

Your New TORREXX™ vaporizer is designed to be reliable and user friendly. Several features allow you to quickly determine the status of your vaporizer.

There are two basic control systems within a TORREXX™:

- 1) Heating system – Figure 3
- 2) Liquid Passage Prevention system – Figure 4

Figure 2 – Heating system

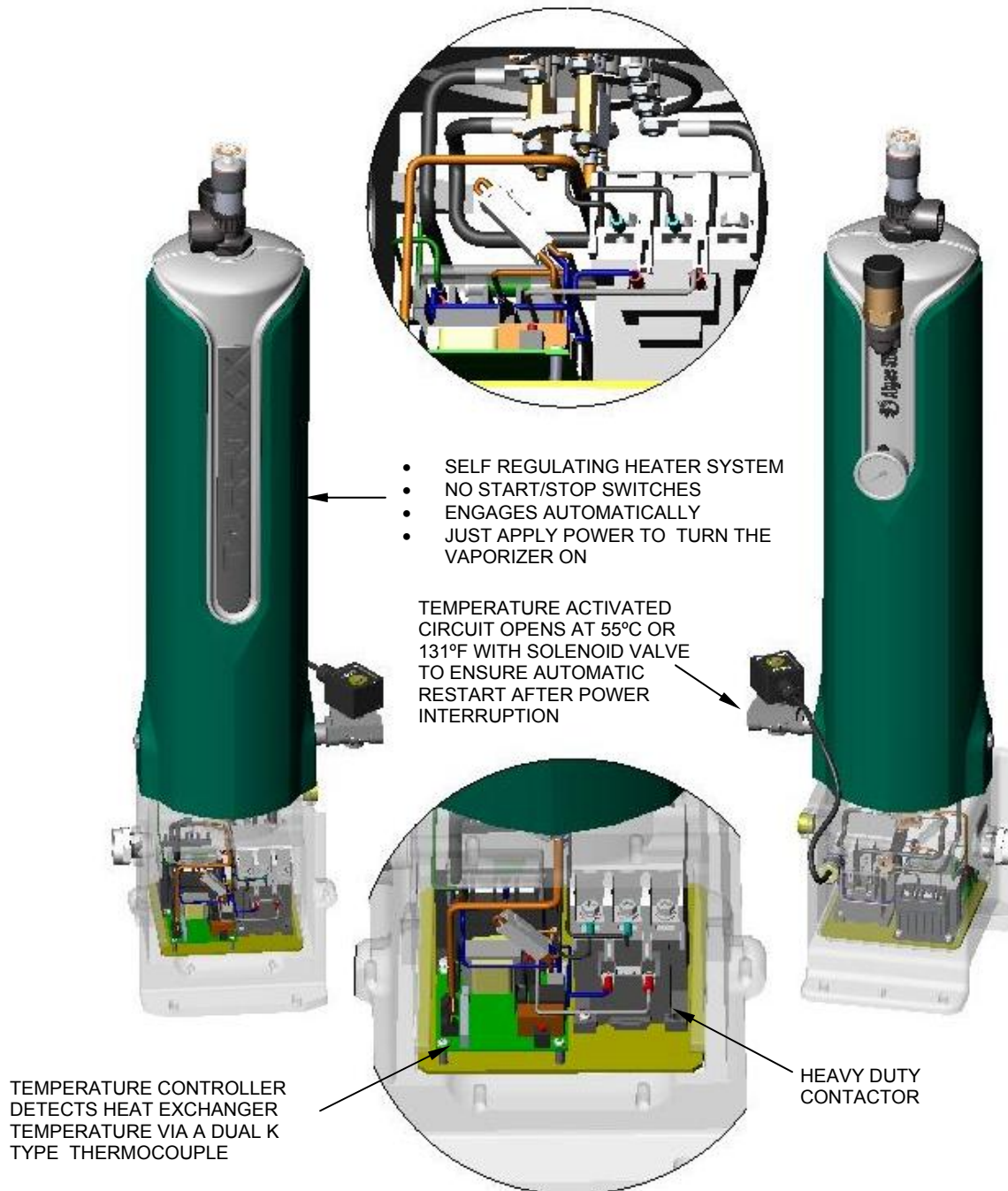

TX100 SHOWN (CE CONFIGURATION) WITH NO OPTIONS

Figure 3 – Liquid Passage Prevention system

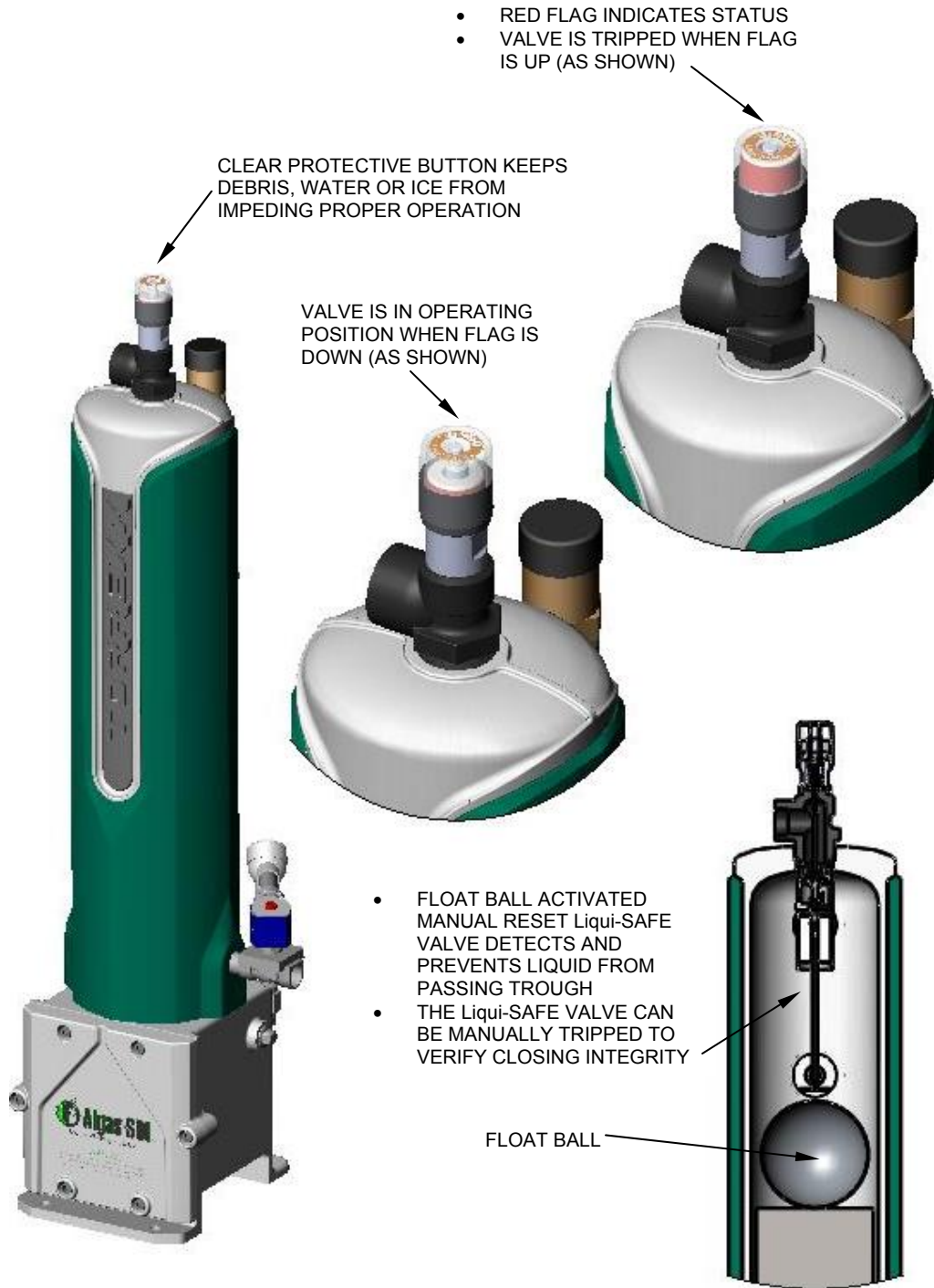

TX100 SHOWN (FM/cFM CONFIGURATION) WITH NO OPTIONS

Figure 4 – TORREXX Major Components Drawing (LPG CONFIGURATION)

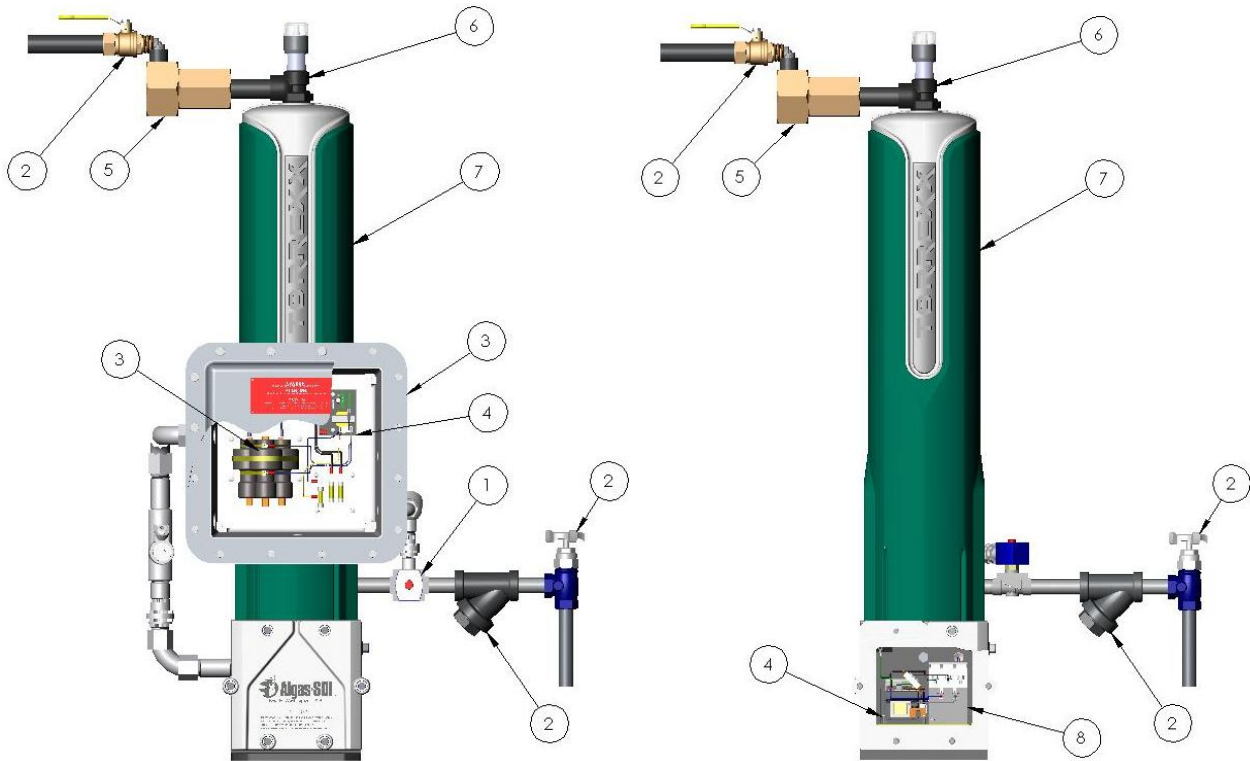

- 1) Liquid Inlet Solenoid Valve
- 2) Valve, Gauge and Strainer kit components (Optional)
- 3) Mercury Relay kit (Optional)
- 4) Temperature Controller Board
- 5) Economy Valve (Optional)
- 6) Liqui-SAFE™ Valve with manual reset
- 7) Insulation Jacket
- 8) Contactor

WARNING

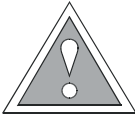

The equipment described in this manual is designed to operate with LP-gas, a flammable fuel under pressure. The nature of the application involves inherent hazards that could result in injury. ONLY a trained and fully qualified person should service this equipment.

NOTE

Prior to installing your new TORREXX vaporizer, check all relevant codes and standards that apply in your local area to ensure compliance!

CAUTION

To prevent ignition of hazardous atmospheres:



Keep flameproof enclosure cover tight, torque to 26.6 Nm (19.6 ft. lbs.) while in service and disconnect power before installing or removing unit from service.

NOTE

Installer must install a terminal box (connection facility).

*Metal Terminal Box (M32)
EEx d II A Gb, (ATEX certified or equivalent) - marking for Europe;*

*Metal Terminal Box (1"):
Class I, Division 1, Group D (UL listed or equivalent) - for US and Canada.*

WARNING



Potential electrostatic charging hazard. Clean insulation with a damp cloth.

CAUTION



Connect only metal electrical conduit or armored cable to the vaporizer sealing fitting.

GENERAL

Install the ASDI TORREXX vaporizer on a level firm base at least 6" above grade and secure it through the four 1/2" holes. Protect the equipment against damage by moving vehicles by use of an appropriate barrier. Consult state, provincial, insurance carriers, and local authorities for installation requirements. Clean all foreign material from all pipelines prior to making final connections. All joints require a pipe sealant approved for LPG, depending on type of service. Test for leaks using an inert gas, such as compressed carbon dioxide or nitrogen, at 1 1/2 times the working pressure or as required by applicable codes. Check all connections using an appropriate leak detection solution or device. Even very small leaks are unacceptable. Eliminate all leaks prior to operation.

Install in accordance with applicable codes and local regulations as required.
Explosion proof seal off must carry the same approvals as the vaporizer in order to maintain the approval of the overall installation.

Figure 5 - Typical TORREXX Installation Drawing with Pump & Vapor Bypass

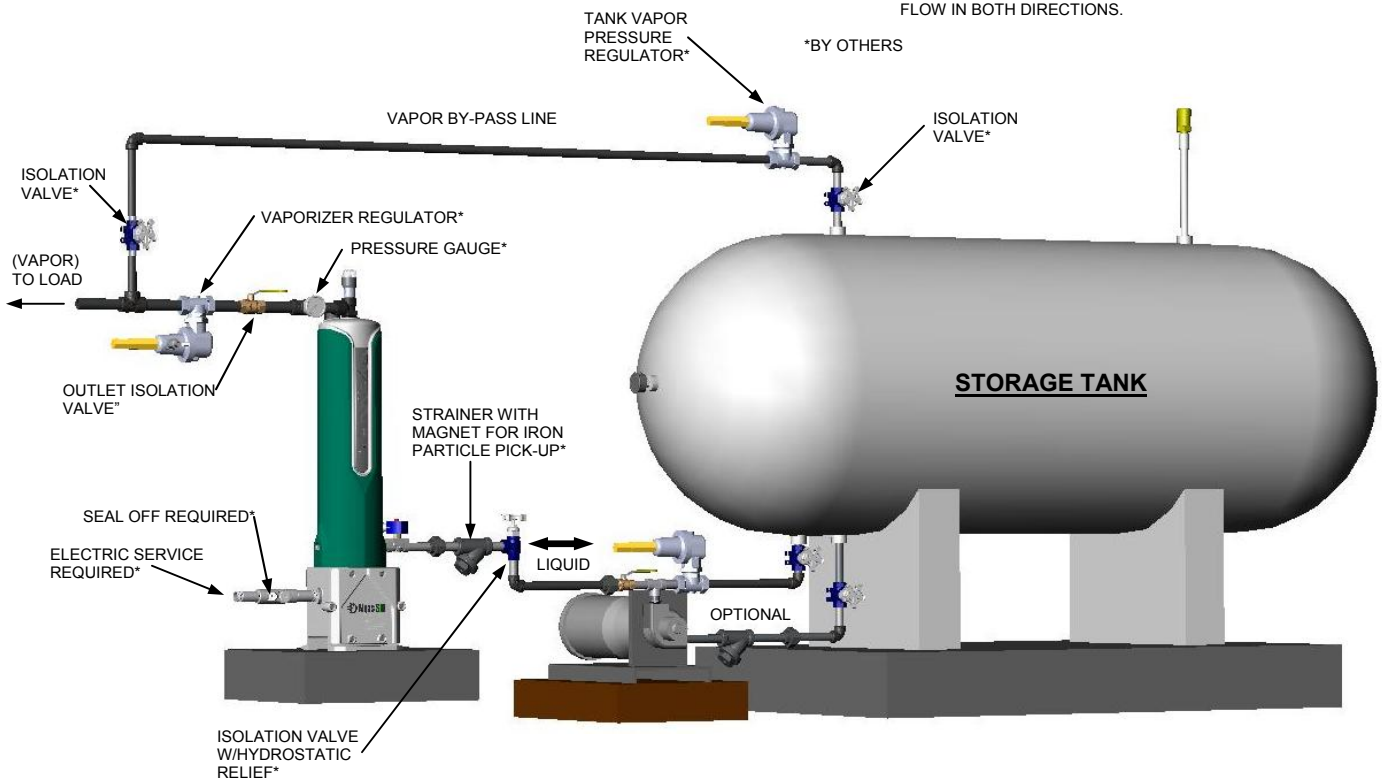

NOTES

1. LIQUID PIPING LOSSES BETWEEN VAPORIZER AND THE TANK MUST NOT EXCEED HYDROSTATIC HEAD WHEN THE PUMP IS SHUT OFF.
2. INSTALL VAPORIZER 1ST STAGE REGULATOR UPSTREAM OF THE TANK VAPOR PRESSURE CONNECTION POINT.
3. SET 1ST STAGE VAPORIZER REGULATOR 2-4 PSIG HIGHER THAN TANK VAPOR PRESSURE REGULATOR SET-POINT.
4. NO CHECK VALVES IN LIQUID LINE. LIQUID MUST BE ABLE TO FLOW IN BOTH DIRECTIONS.

Note: The vapor bypass line is not required except when you have the Economy Operation option. In other installations, it is recommended because it will provide vapor from the tank to the load in case of vaporizer failure or power failure but it is not required. Vaporizer will operate properly without the bypass.

Figure 6 - Typical TORREXX Installation Drawing with Vapor Bypass and No Pump

NOTES

1. LIQUID PIPING LOSSES BETWEEN VAPORIZER AND THE TANK MUST NOT EXCEED HYDROSTATIC HEAD WHEN THE PUMP IS SHUT OFF.
2. INSTALL VAPORIZER 1ST STAGE REGULATOR UPSTREAM OF THE TANK VAPOR PRESSURE CONNECTION POINT.
3. SET 1ST STAGE VAPORIZER REULATOR 2-4 PSIG HIGHER THAN TANK VAPOR PRESSURE REGULATOR SET-POINT.
4. NO CHECK VALVES IN LIQUID LINE. LIQUID MUST BE ABLE TO FLOW IN BOTH DIRECTIONS.

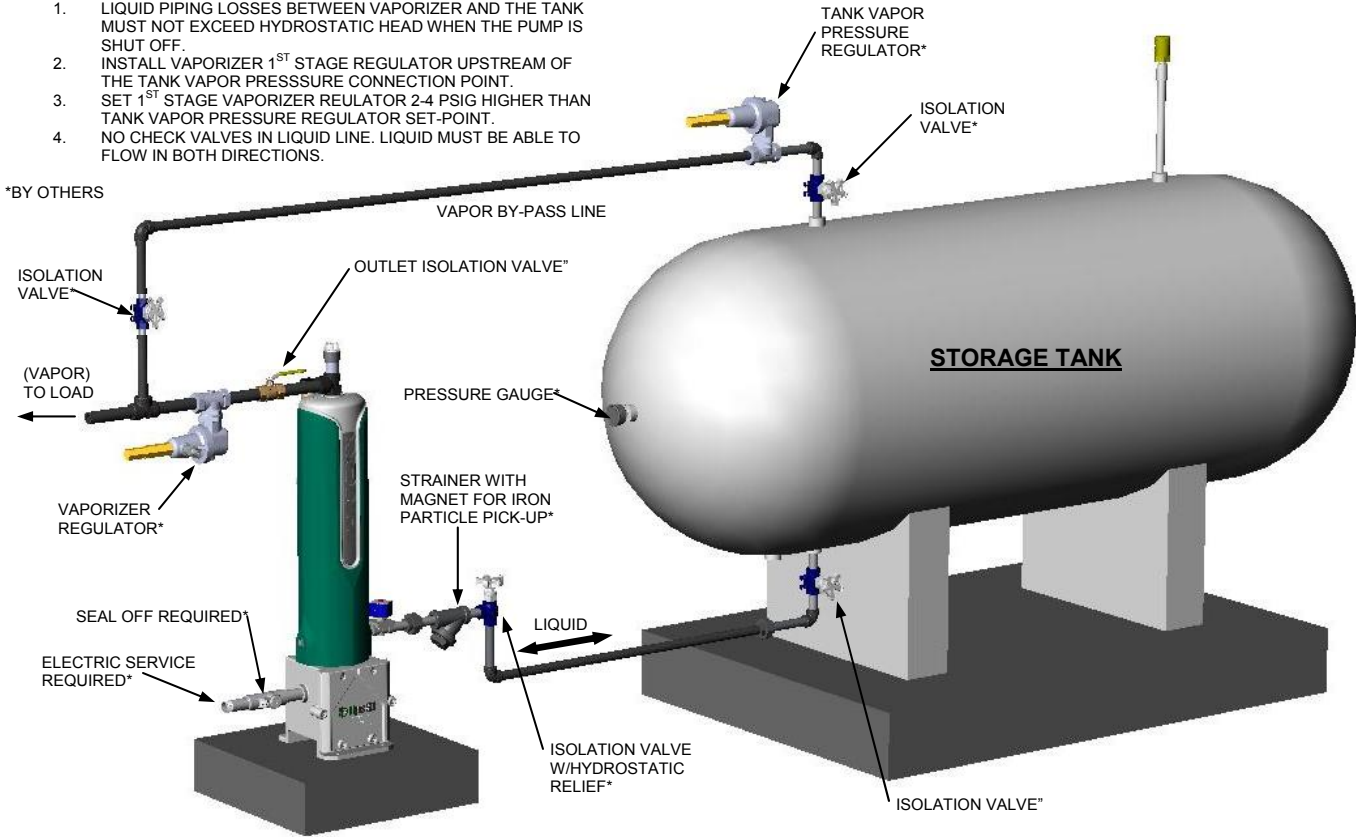
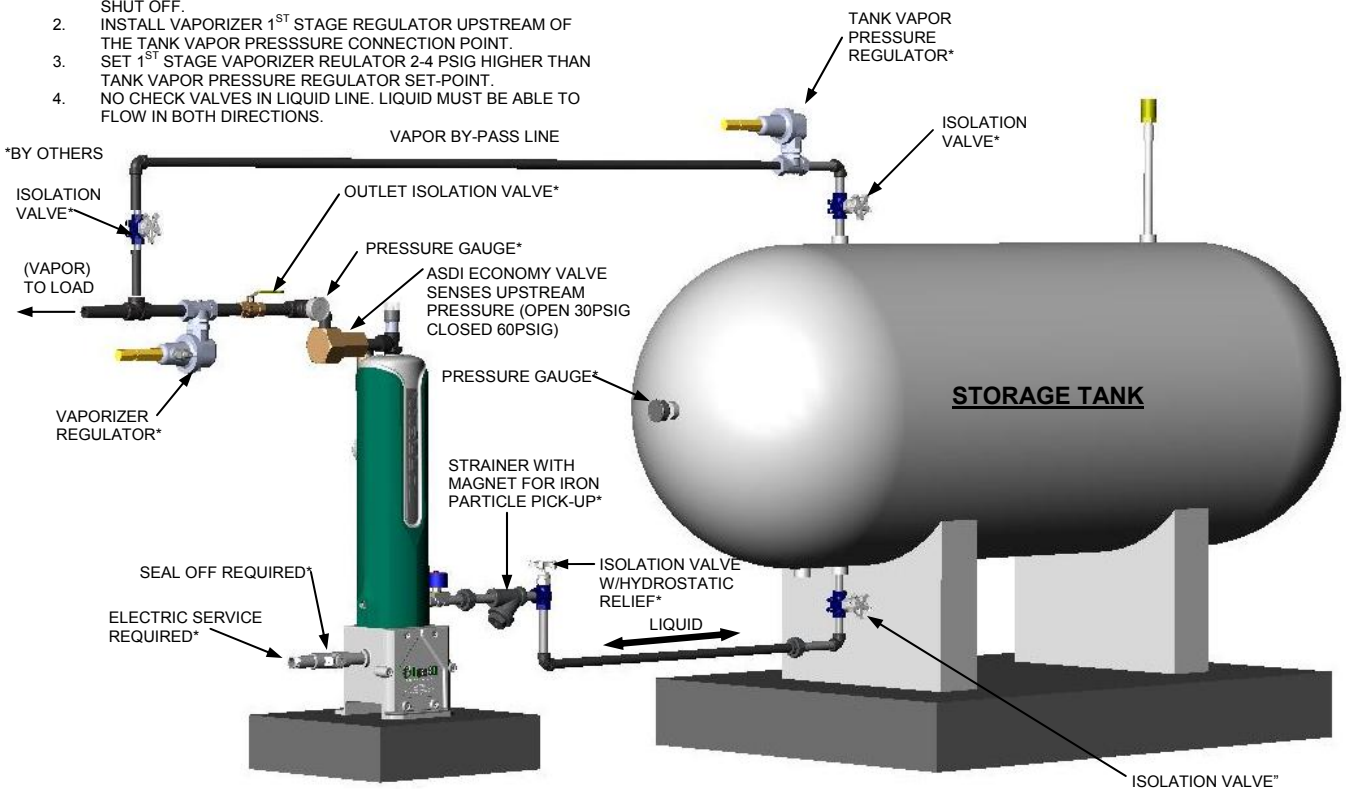

Figure 7 - Typical TORREXX Installation Drawing with Economy Operation and Vapor Bypass

NOTES

1. LIQUID PIPING LOSSES BETWEEN VAPORIZER AND THE TANK MUST NOT EXCEED HYDROSTATIC HEAD WHEN THE PUMP IS SHUT OFF.
2. INSTALL VAPORIZER 1ST STAGE REGULATOR UPSTREAM OF THE TANK VAPOR PRESSURE CONNECTION POINT.
3. SET 1ST STAGE VAPORIZER REULATOR 2-4 PSIG HIGHER THAN TANK VAPOR PRESSURE REGULATOR SET-POINT.
4. NO CHECK VALVES IN LIQUID LINE. LIQUID MUST BE ABLE TO FLOW IN BOTH DIRECTIONS.



Note: Economy option cannot be used on an installation that requires a pump.

Figure 8 – Typical TORREXX Installation for manifolding 2 vaporizers.

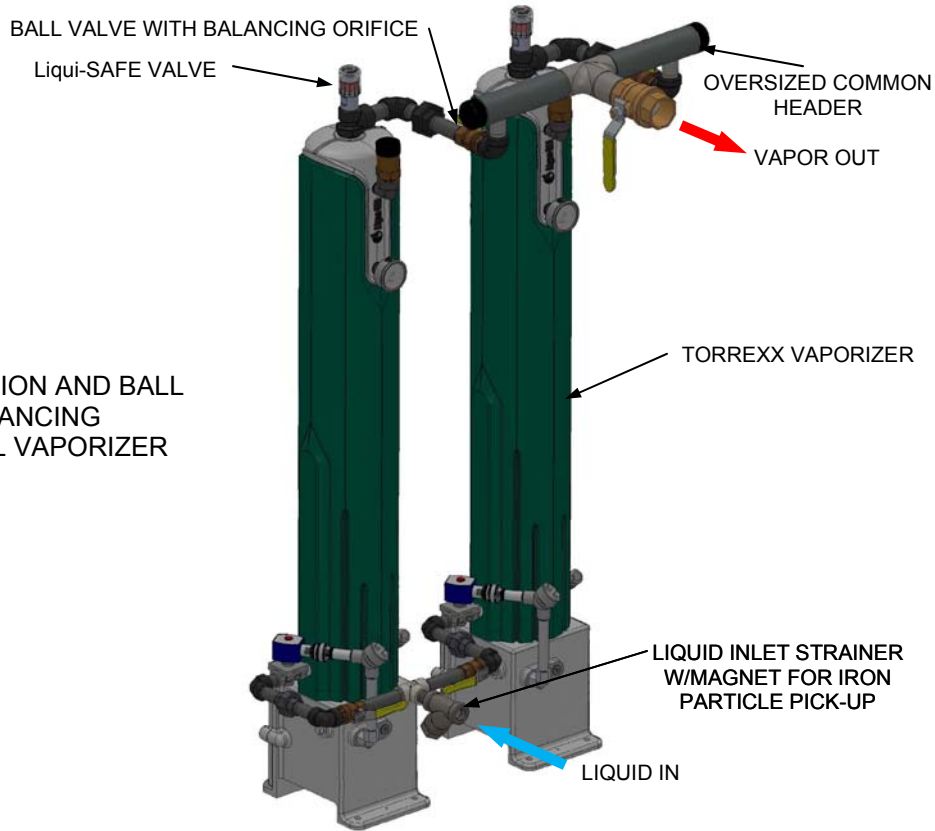

NOTE: USE 1" UNION AND BALL VALVE WITH BALANCING ORIFICES ON ALL VAPORIZER OUTLETS

Figure 9 – Typical TORREXX Installation for manifolding 3 vaporizers.

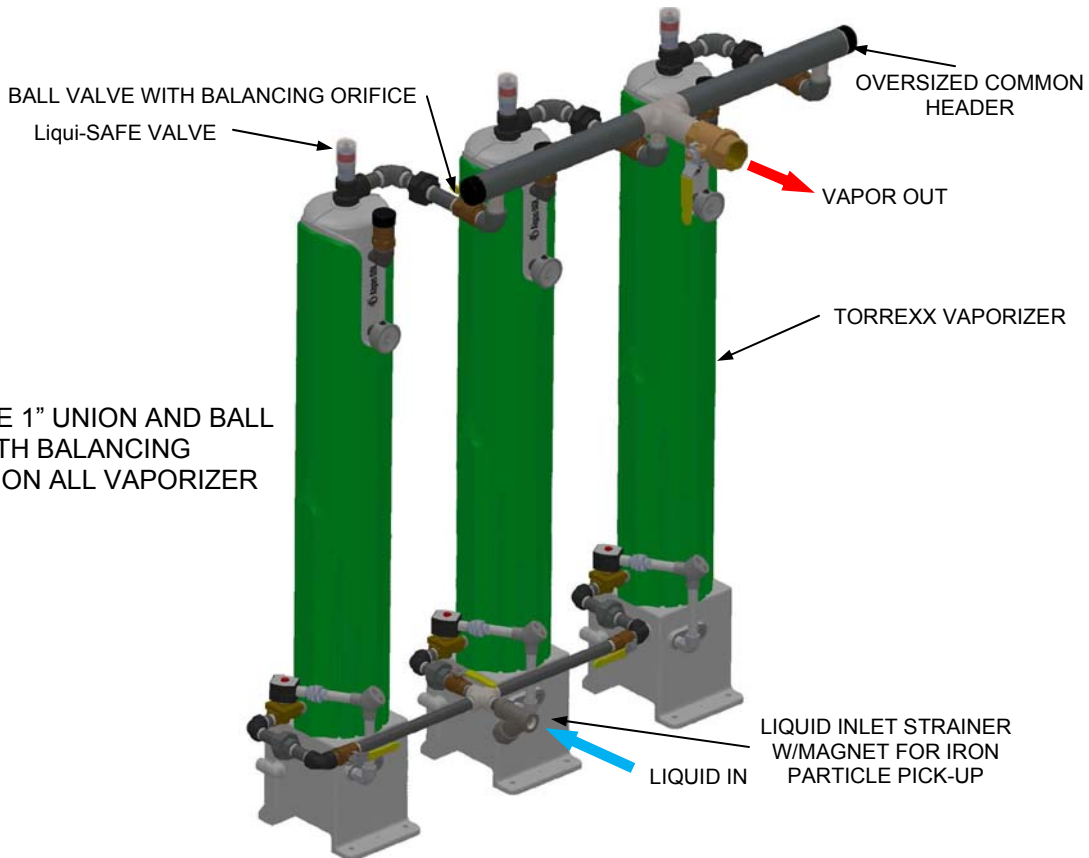

NOTE: USE 1" UNION AND BALL VALVE WITH BALANCING ORIFICES ON ALL VAPORIZER OUTLETS

LIQUID LINE

Size the liquid line from the storage tank to the vaporizer to supply the vaporizer at full capacity with a minimal pressure drop. A liquid line-sizing chart is provided in **Table 6**. Install a liquid line strainer with magnet for iron particle pickup at the vaporizer inlet.

CAUTION

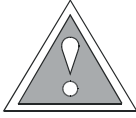

A liquid pump must be installed if the pressure drop in the liquid line between the vaporizer and the tank exceeds the hydrostatic liquid head in the storage tank. ONE FOOT OF LIQUID PROPANE EQUALS .21 PSI! Liquid line frosting is a sure indication of too much pressure drop in the liquid line.

LIQUID PUMP

Is a Liquid Pump necessary? What are your vapor pressure requirements?

Pressure in the storage tank depends on temperature See Table 5. A good “rule of thumb” for determining when a Liquid Pump is necessary is this: If the storage pressure will not always exceed the required distribution pressure by 5 psig (0.35 kg/cm²), a pump is necessary. Install an ASDI STABILAIRE Liquid Pump in the liquid line close to the storage tank. To prevent cavitation, place the liquid strainer at least five feet upstream of the pump inlet. Typically a pump is not required unless a mixing system is used or temperature at the installation will be extremely low, causing the pressure to drop below the required process pressure. **When using a pump, vaporizer capacity may decrease due to increase in boiling point of LPG. Increasing boiling point requires larger portion of heat exchanger area to be used for liquid heating instead for boiling and vaporization. Please consult ASDI when using a pump.**

VAPOR LINE

Install an appropriate regulator immediately downstream of the vapor outlet. Connect pipe from the outlet port of the regulator to the distribution system. Further reduction of downstream pressure requires a “Second Stage” regulator close to the consuming equipment. Properly sized piping and regulators will insure satisfactory service.

NOTE

For safety reasons both FIRST and SECOND stage regulators must be 250 psig (17.58 cm/kg²) inlet pressure rated!

SAFETY RELIEF VALVE

If the vaporizer is to be installed within an enclosure or building, VENT THE SAFETY RELIEF VALVE OUTSIDE THE ENCLOSURE AND REDIRECT THE DISCHARGE UPWARD. A pipe-away adapter must be used at the relief valve. Always install a rain-cap or similar device to prevent water and other debris from entering the relief discharge. If water enters, it may freeze and prevent the relief valve from proper discharge, creating a potentially hazardous situation.

ELECTRICAL SERVICE

The rating plate on the vaporizer and the data sheet provided with the manual provides your specific vaporizer's electrical power requirements and the drawing numbers of the appropriate wiring diagrams and schematics. This unit is constructed to meet NFPA 70 Class I, Division 1, Group D requirements or ATEX Zone I requirements (depending on model). All wiring to the unit, including the ground connection, must meet the applicable codes for the area in which it is being installed. Wire size and type must comply with the applicable codes for the area in which it is being installed. The Tables 1 through 4 list the recommended wire size for the different models. Those tables are to be used as guides only. Provide a fused disconnect outside of the classified area. If it is not within sight of the vaporizer, the fused disconnect must have a locking device. Run wire within rigid conduit, and install a seal-off at the connection of the field conduit to the vaporizer.

WIRE SIZE

When selecting the type and size of wire used to install the TORREXX series electric vaporizers, please take into account the following environmental information:

- Maximum enclosure surface temperature: 65° C (150°F).
- Maximum enclosure ambient temperature: 65° C (150°F).
- Maximum temperature allowed at contactor terminals: 90° C (195° F).
- Current draw of vaporizer: Indicated on vaporizer rating plate and on the data sheet.
- Contactor terminal lug wire size range: #2 - 10.

As the length of the wire run affects the overall wire size requirements, always refer to NFPA 70 (NEC) for proper wire selection. Several wire-sizing charts have been provided for determining the size of wire required due to load and length of wire.

When installing the wire it is important to have a good connection at the terminal lugs. Loose terminals may cause an excessive temperature rise at the terminal lugs, which can lead, to premature contactor failure, transformer failure, and/or overheating and possible destruction of the transformer. For this reason it is strongly recommended that the wire terminations be checked and re-tightened periodically to prevent excessive overheating at the terminals due to loose connections.

Table 1 – Wire Length Chart [#4 AWG]

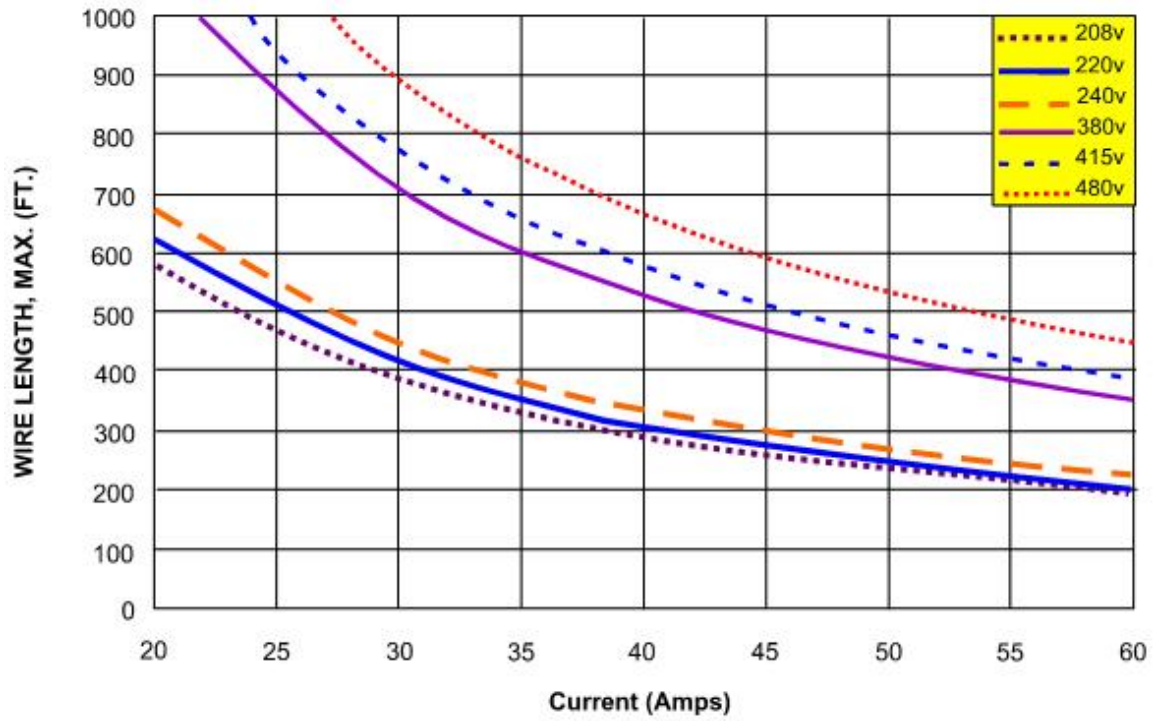

Table 2 – Wire Length Chart [#6 AWG]

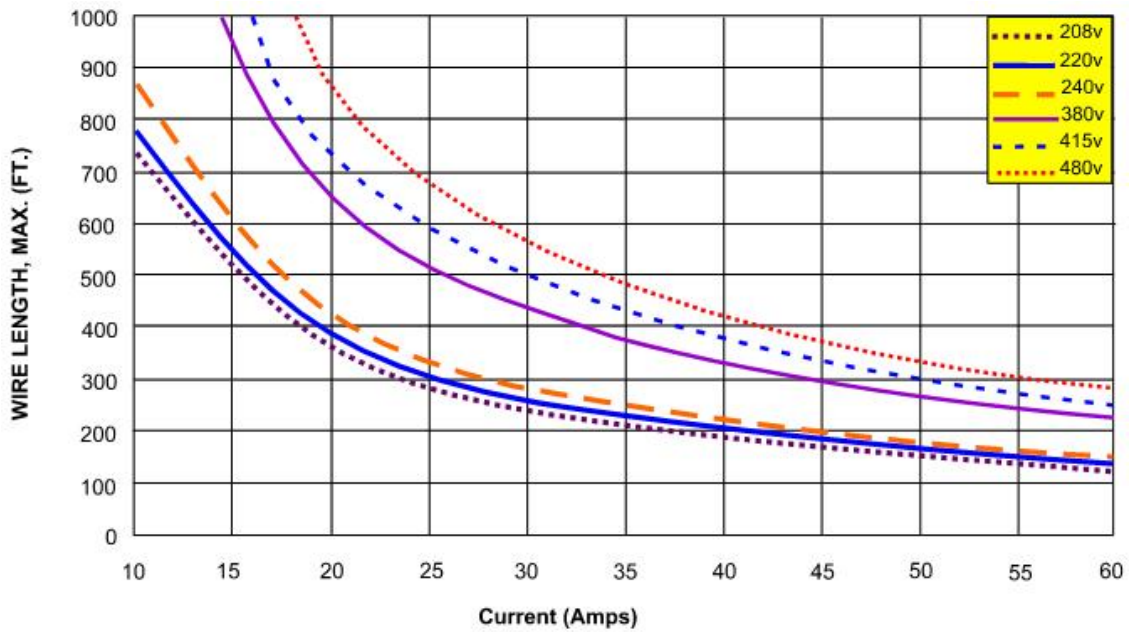

Table 3 – Wire Length Chart [#8 AWG]

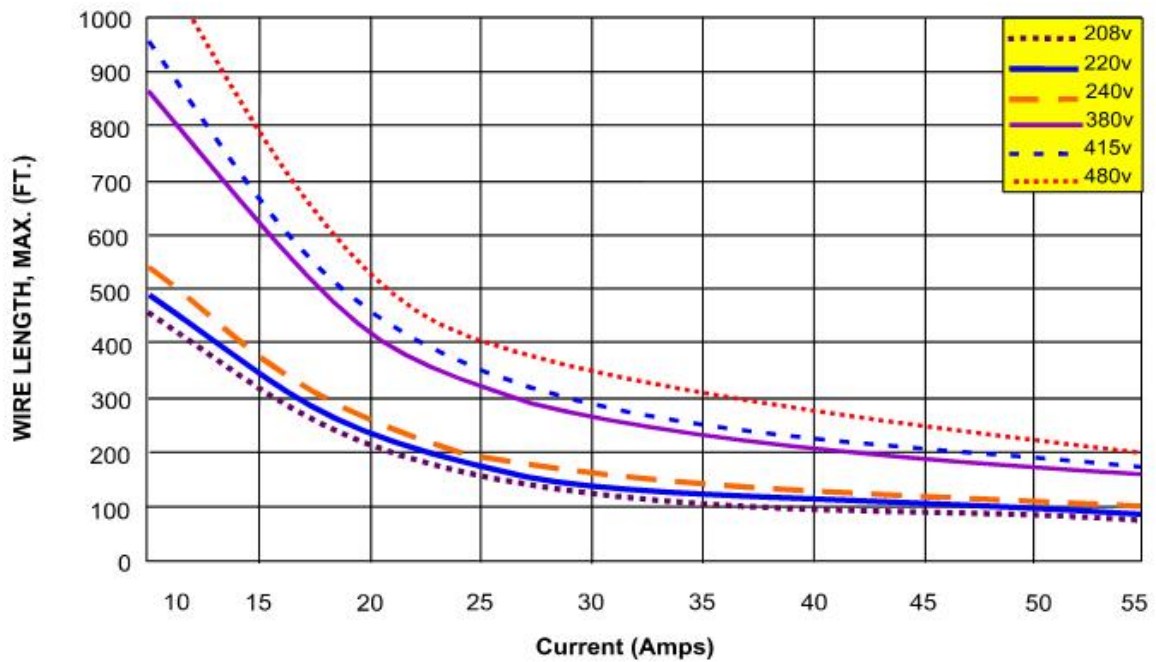

Table 4 – Wire Length Chart [10 AWG]

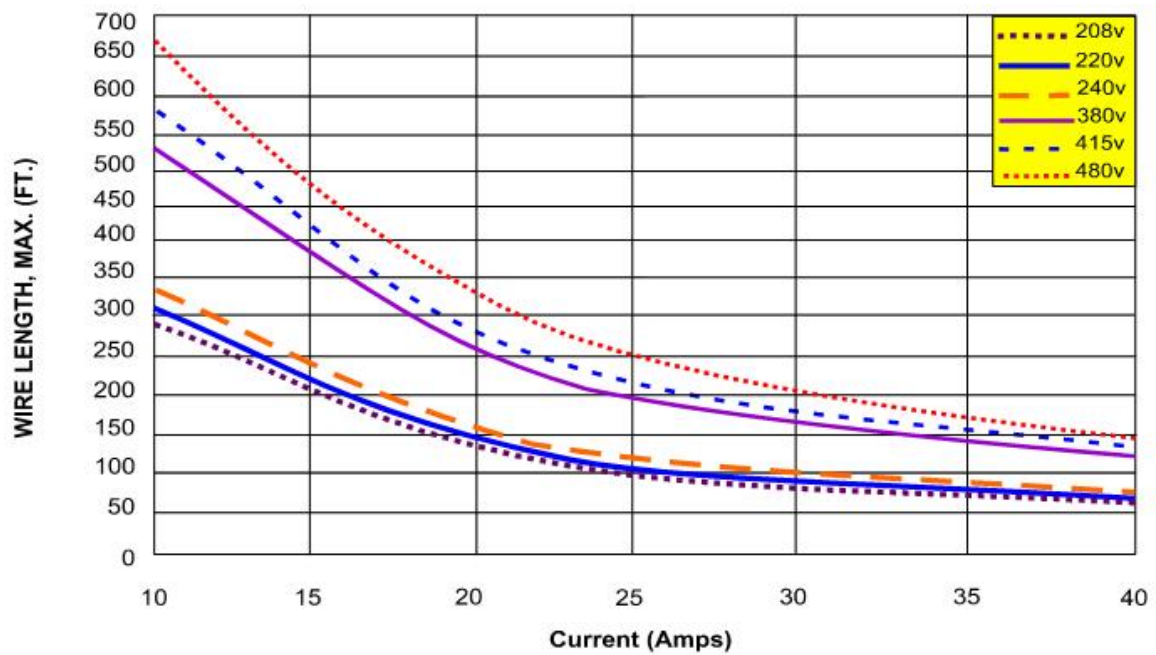

Table 5 – Liquid Temperature vs. Tank Pressure Chart

Liquid Temperature		Propane		Butane		Ammonia	
		Tank Gauge Pressure		Tank Gauge Pressure		Tank Gauge Pressure	
°F	°C	PSI	kPa	PSI	kPa	PSI	kPa
-43.73	-41.7	0	0				
-40	-39.6	1.4	9.6				
-35	-36.9	3.4	23.6				
-30	-34.1	5.6	38.9				
-25	-31.4	8.0	55.6			1.2	8.5
-20	-28.6	10.7	73.7			3.5	24.4
-15	-25.9	13.6	93.5			6.2	42.6
-10	-23.1	16.7	114.9			8.9	61.8
				NOTE: Below 30°F or -10°C, Butane is a liquid at normal atmospheric pressure.			
-5	-20.4	20.0	136.1			12.2	84.2
0	-17.6	23.6	163.1			15.6	107.7
5	-14.9	27.6	189.9			19.6	134.9
10	-12.1	31.7	218.9			23.7	163.3
15	-9.35	36.2	249.9			28.4	195.9
20	-6.6	41.1	283.1			33.4	230.0
25	-3.	46.2	318.7			39.0	268.9
30	-1.1	51.7	356.7			44.9	309.3
35	1.7	57.6	397.0	1.2	8.6	51.5	355.1
40	4.4	63.8	440.1	2.9	20.1	58.4	402.8
45	7.2	70.5	485.8	4.8	33.2	66.0	455.3
50	9.9	77.5	534.3	6.9	47.2	74.3	511.9
55	12.7	84.9	585.7	9	62.0	83.1	572.9
60	15.4	92.8	640.1	11.3	78.0	92.6	638.6
65	18.2	101.2	697.6	13.8	95.3	102.8	709.1
70	20.9	109.9	758.3	16.5	113.8	113.9	784.5
75	23.7	119.3	822.4	19.3	133.1	125.5	865.2
80	26.4	129.1	889.9	22.4	154.7	137.9	951.4
85	29.2	139.7	963.5	25.8	177.9	151.3	1043.3
90	31.9	150.2	1035.7	29.2	201.4	165.5	1141.3
95	34.7	161.6	1114.2	32.7	225.3	181.1	1248.8
100	37.4	173.6	1196.6	36.7	252.8	196.7	1356.2
105	40.2	186.1	1283.1	41.0	282.8	214.2	1477.1
110	42.9	199.2	1373.7	46.6	321.1	231.8	1597.9
115	45.7	213.0	1468.6	50.3	346.7	251.4	1733.4
120	48.4	227.4	1567.9	55.3	381.1	271.0	1868.9
125	51.2	242.5	1671.9	60.5	417.3	292.9	2019.9
130	53.9	258.2	1780.5	66.1	455.9	314.9	2171.0
135	56.7	274.7	1893.9	72.1	497.3	339.2	2338.8
140	59.4	291.9	2012.4	78.2	538.9	363.5	2506.5

Table 6 – LPG liquid line sizing chart (Minimum Pipe Size)

Capacity of units MMBTU (Kcal)	Distance from storage to vaporizer - feet (meters)*									
	Kg	LBS (GPH)	25 (8)	50 (15)	75 (23)	100 (31)	150 (36)	200 (61)	300 (92)	400 (122)
1.146 (288,792)	25	55 (12.5)	½"	½"	½"	½"	½"	¾"	¾"	¾"
2.292 (557,584)	50	110 (25)	½"	½"	½"	¾"	¾"	1"	1"	1"
4.584 (1,155,168)	100	220 (50)	½"	¾"	¾"	¾"	1"	1"	1"	1¼"
7.280 (1,834,537)	160	352 (80)	¾"	¾"	1"	1"	1"	1¼"	1¼"	1¼"
10.920 (2,751,806)	240	530 (120)	1"	1"	1¼"	1¼"	1¼"	1½"	1½"	1½"
14.665 (3,668,800)	320	530 (160)	1"	1"	1¼"	1¼"	1¼"	1½"	1½"	1½"

Table 7 – Equivalent Pipe Length of Various Valves and Fittings (Length in Feet/Meters)

Size/Description	½" (1.27 cm)	¾" (1.91 cm)	1" (2.54 cm)	1 ¼" (3.18 cm)	1 ½" (3.81 cm)
Globe Valve	15.5/4.72	21/6.40	27/8.23	36/10.97	43/13.11
Gate Valve	0.6/0.18	0.8/0.24	1/0.30	1.4/0.43	1.6/0.49
Angle Valve	8/2.44	11/3.35	14/4.23	18/5.49	21/6.40
Elbow, 90	1.4/0.43	1.9/0.58	2.4/0.73	3.2/0.98	3.8/1.19
Elbow, 45	0.7/0.21	1/0.30	1.2/0.37	1.6/0.49	2/0.61
Elbow, 90 STR	2.3/0.70	3.1/0.94	4/1.22	5.3/1.62	6.3/1.92
Tee	2.7/0.82	3.7/1.13	4.8/1.46	6.4/1.95	7.5/2.29

GENERAL

TORREXX Electric Vaporizer utilizes a finned cast aluminum heater core. The heater core contains multiple cast-in resistance heater elements. Multiple wiring configurations allow a variety of AC input voltages to suit local power supply requirements.

Liquid LPG enters the vaporizer through the Liquid Inlet Solenoid Valve at the base of the pressure vessel.

During operation, a K-type thermocouple temperature sensor and solid state control system maintain the core temperature at 165°F (74°C). As the temperature increases on start, the Liquid Inlet Solenoid Valve opens at 131°F (55°C), liquid enters the vaporizer and comes in contact with the heater core. Vaporization results as the liquid extracts energy (heat) from the heater core. As the heater core cools, the Temperature Sensor provides a signal to the control system to energize the heater power contactor, applying power to the heater elements.

OPERATING INSTRUCTIONS

- 1) Complete the installation and leak test.
- 2) Check current and voltage to verify proper operation of the vaporizer.
- 3) This unit will not be damaged by operating the unit in a “dry” condition. It is not necessary to have liquid in the unit for testing or evaluation.
- 4) Normal operating temperature is 165°F (74°C). Use caution when working around vaporizer.

STARTING THE VAPORIZER

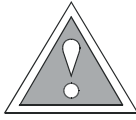

CAUTION

Power wiring terminals may become loose during shipping. Prior to applying electrical power all power wiring terminals must be retightened. Recheck terminals and retighten as necessary after the first month in operation.

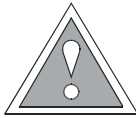

CAUTION

Do not start the vaporizer when both inlet and outlet isolation valves are closed. Pressure can build in the vaporizer during startup and blow the relief valve.

- 1) Close the outlet isolation valve.
- 2) Open all valves between the storage tank and the vaporizer to allow liquid flow to the vaporizer when the solenoid valve opens.
- 3) Apply power. A small “click” should be heard immediately afterwards. The vaporizer heater elements are now energized. It will take approximately 60 seconds for the vaporizer to reach operating temperature. After reaches the operating temperature, the Inlet Solenoid Valve will open automatically to allow LPG to enter. Wait approximately 2 minutes so that excess LPG is pushed back to the storage tank.
- 4) Carefully press the Button on top of the Liqui-SAFE™ valve all the way down and SLOWLY release it. A latch mechanism inside the Liqui-SAFE™ valve will keep the Red Flag at the down position, indicating the valve is open and in operating position.
- 5) TORREXX vaporizer is now ready to supply vapor. Slowly open the outlet isolation valve to pressurize the supply piping. Then, fully open the outlet isolation valve to allow vapor to flow to the load. Heater will cycle automatically to match the flow conditions.

STOPPING THE VAPORIZER

- 1) Close the outlet isolation valve.
- 2) Disconnect power.

PURGING THE VAPORIZER

Purging procedure should be followed anytime a vaporizer needs to be maintained, serviced, relocated or shut down for any other reason.

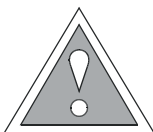

CAUTION

Prior to purging the vaporizer, ensure that there are no closed ball valves or back check valves restricting the flow of liquid to the tank.

- 1) Close the valve at the outlet of the vaporizer.
- 2) If the vaporizer is not operating, start the vaporizer.

- 3) Allow at most 5 minutes for vaporizer to heat up and push most of the remaining liquid back into the tank. You should hear the contactor cycle off.
- 4) Close the tank liquid outlet valve.
- 5) Open the vaporizer outlet valve and flare or allow attached equipment to consume remaining gas in the line.

GENERAL

TORREXX vaporizer is designed for long term trouble free operation. Because of the nature of its use, and the severe duty it receives, it is important to provide scheduled maintenance. A list of RECOMMENDED SPARE PARTS is located in the back of this manual.

Item	3 Months	6 Months	Annual
Inlet strainer	During initial operation remove accumulated debris every 3 months or sooner. Establish cleaning schedule according to the amount of debris present.	Inspect and remove debris.	Inspect and remove debris.
Safety relief valve			Visually check. Replace if leakage is observed. Relief valve is not serviceable in the field. Be sure it is covered with an appropriate plastic or rubber cap to prevent rain and debris from entering.
Inlet solenoid valve	Verify inlet solenoid valve seating integrity. Seal should be bubble tight from tank pressure to vaporizer outlet. Back flow is normal. Replace diaphragm assembly or valve body if damaged or leaking.		Change the diaphragm and operating parts if unit is being used regularly or if the valve makes unusual noises (i.e. buzzing etc.) during operation. See the enclosed maintenance and operation sheet for ASCO 2 way valves.
Electronic wiring and connections		Check primary terminal lug tension.	Visually inspect for corrosion, loose wires, heat buildup and charring.
Liqui-SAFE valve		Conduct performance check every 6 months as described on page 5-21.	Replace Liqui-SAFE valve o-rings every two years. Liqui-SAFE valve is not serviceable in the field.
Heavy ends drain	Check heat exchanger for possible heavy ends accumulation. To do this you must have heavy ends drain kit installed. Ensure there are no sources of ignition within 25ft. Remove drain valve plug and slowly open the drain valve. After draining heavy ends, close the valve and re-install plug. NOTE: In areas of poor gas quality this maintenance procedure should be performed every other week.		

CONTACTOR INSPECTION



WARNING

Contactors that power the heaters produce sparks which may ignite any flammable vapors in the area when the control box cover is removed. If the cover must be removed, shut off the power, remove the cover and check very carefully for fumes, leaks, or any indication of flammable vapors in the atmosphere or in the control enclosure.

Do not re-apply power if fumes are present. They may ignite!

CAUTION

Keep a fire extinguisher available in the immediate vicinity before re-applying power when the control cover is removed.

TORREXX vaporizer utilizes an electro-mechanical contactor to switch power to the heating elements. Since contactors wear out in normal operation, it is prudent industry practice to inspect them on a preventive maintenance basis. Manufacturers define a cycle life for contactors based upon operations at rated current. The cycle rate of the contactor in vaporizers varies due to liquid temperature/pressure, percent loading of the vaporizer, and installation specifics. Vaporizer testing has demonstrated that cycle rates are greatest at around 50% of the vaporizer loading and least when vaporizers are energized in a standby mode.

We recommend the following inspection schedule for contactors:

- ◆ 5000 hours for vaporizers in service
- ◆ 30,000 hours for vaporizers in standby mode
- ◆ For vaporizers operating in a combination of service and standby modes, we are providing a simple formula to help determine when contactors should be inspected.

Contactors life factor (LF) can be defined as follows:

$$LF = \frac{X}{5000} + \frac{Y}{30000}$$

When

X = hours of vaporizer operation mode

Y = hours of vaporizer in standby mode

If LF is 1 or greater, the contactor should be replaced.

This data is to be used only as a guide. It is not "fool-proof" as the environment your vaporizer operates in and its load may affect the contactor life span.

Liqui-SAFE™ valve – Performance check (Every 6 months)

- I Latch operation. – While the valve is in the open position and the Red Flag is down, press Button and release QUICKLY. This will cause the valve to close and the Red Flag should pop up. Carefully press the Button again all the way down and release SLOWLY. The valve will stay open.
- II Leak detection. – Follow the instructions in “I” to manually open and close the valve. Perform leak tests in both conditions. If a leak is detected at the Valve Body (Step 1) when the valve is open, replace the Valve Body O-ring (This can be performed in the field. See below.) If a leak is detected in Step 5 when the valve is closed (see Figure 11), follow the “Liqui-SAFE™ valve – Service Instructions” and change all the o-rings. (This service should not be performed in the field.)

Figure 10 – Follow 1 to 7 below to check the Liqui-SAFE™ valve operation

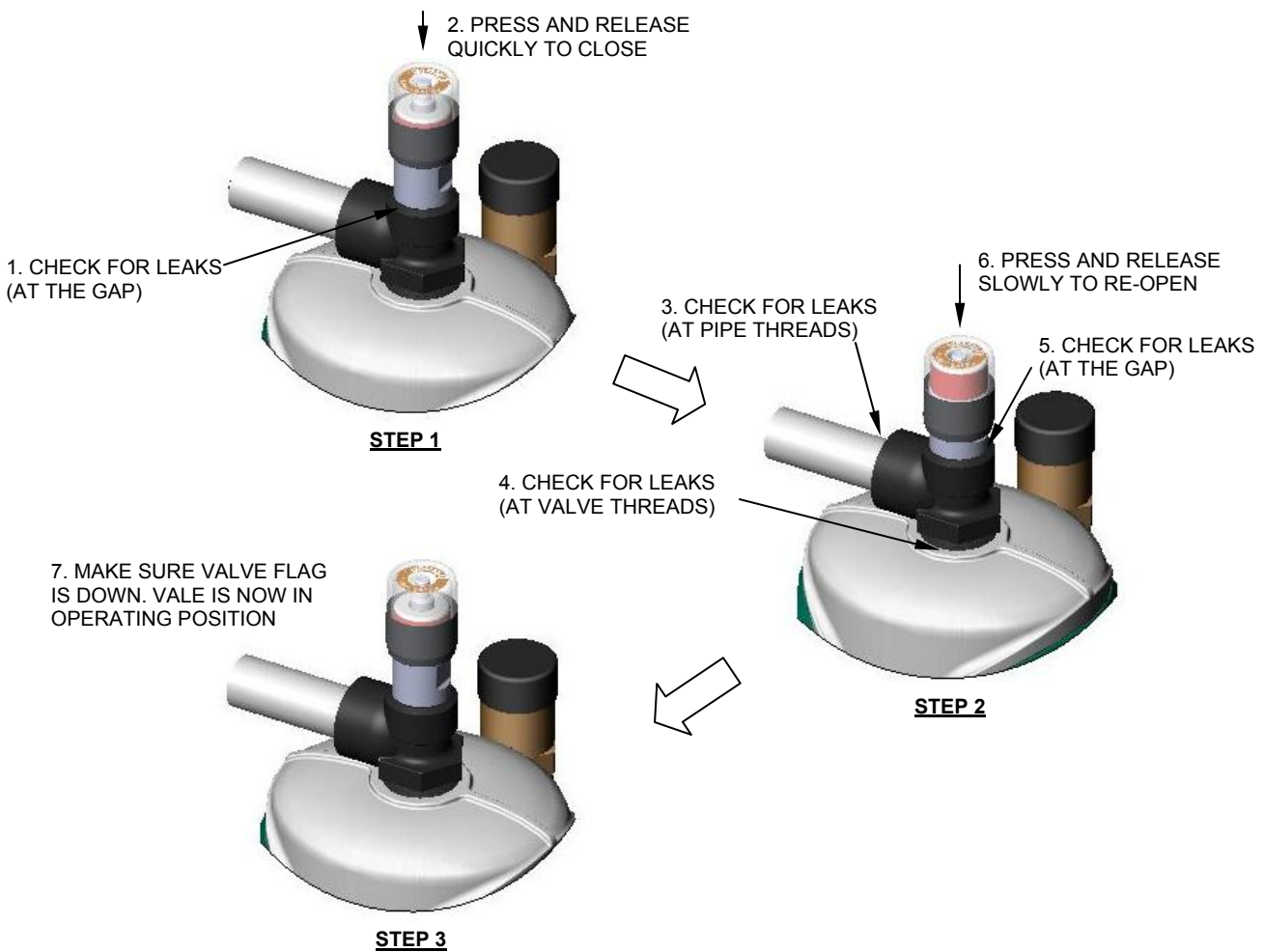

WARNING



Extreme caution must be taken due to the potential of flammable vapors being exposed to the atmosphere creating an ignition. Do not operate any equipment that may create a spark from this point. Do not open the explosion-proof enclosure.

Liqui-SAFE™ Valve – Service Instructions

There are four (4) o-rings in the Liqui-SAFE™ valve and these are the Button Post o-ring, Valve Body o-ring, Valve Seat o-ring and Valve Stem Base o-ring. In order to keep the valve working at its peak conditions, replacement of all the o-rings according to the maintenance schedule is strongly recommended. Due to the complexity of the valve and the number of parts involved, this service should NOT be done in the field. Follow the 7 Steps below to service the Liqui-SAFE™ valve. Clean all the metal parts with WD-40. Re-assemble all the parts. Simulate the tripping action of the valve and verify the tripping force applied on the Extension Stem is between 0.2 lbf (0.89 N) and 0.5 lbf (2.22 N).

Figure 11A – STEP 1 – Be sure that the Liqui-SAFE™ valve is in the close position as shown



Figure 11B – STEP 2 – Unscrew reset button base and remove the spring



Figure 11C – STEP 3 – Replace button post internal o-ring

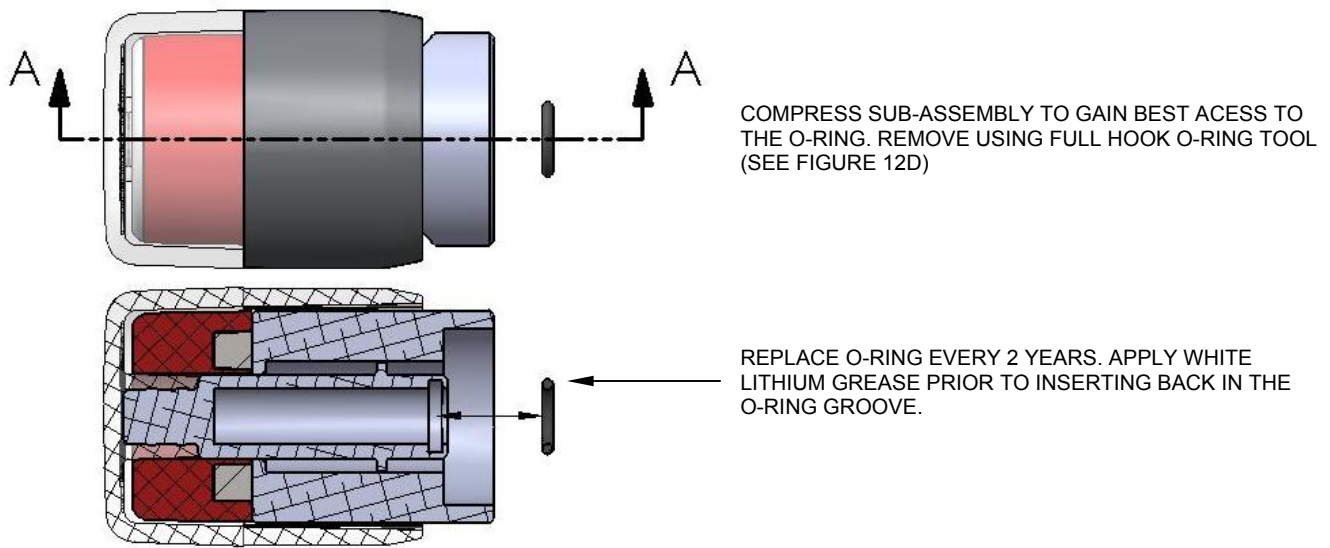

Figure 11D – Full hook o-ring tool



Figure 11E – STEP 4 – Unscrew valve latch body

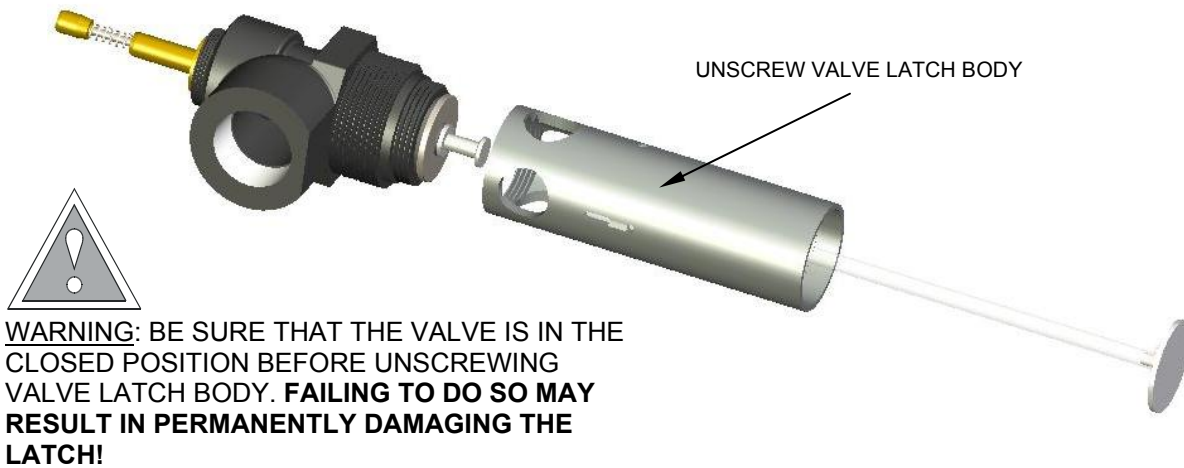

Figure 11F – STEP 5 – Replace valve body static o-ring

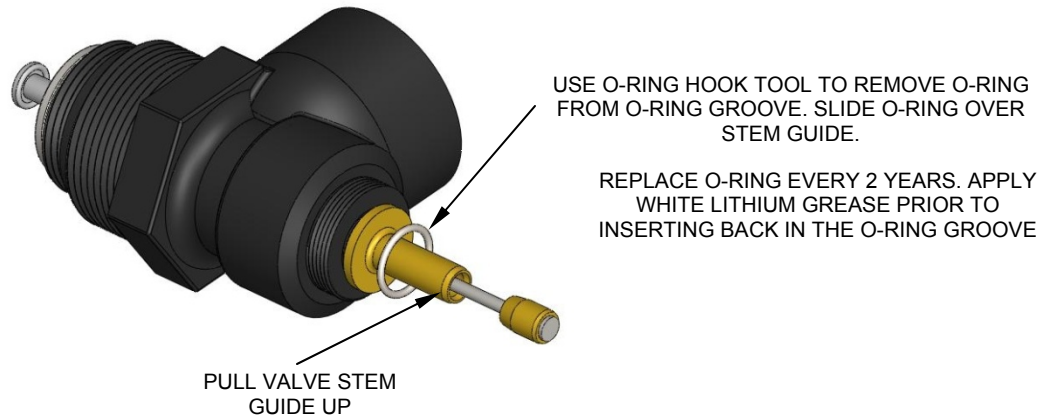
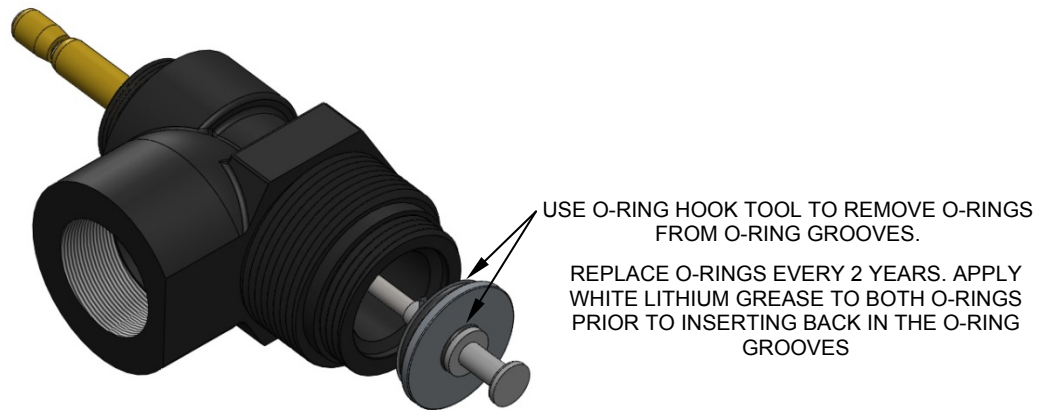

Figure 11G – STEP 6 – Replace valve seat and valve stem base o-rings.



IMPORTANT:

- Always perform a functional check and leak test (see *Figure 11*) of the re-assembled valve to ensure that it actuates per design and that valve seat o-ring seals properly against the valve body. A proper seal is present when the large valve seat o-ring shown in *Figure 12G* is sealing along the entire surface on the bottom face of the valve body.
- Please note that on older versions of the valve (installed on vaporizers built before 8/11/2010) it was necessary to remove the driving magnet in order to access and replace the o-ring below the valve stem guide. When reassembling the old version of the valve after servicing o-rings, make sure that super glue is applied to the inside of the magnet holder and that magnet is firmly pressed in until it bottoms out. Allow sufficient time for glue to dry.

General

Follow the troubleshooting guide below to identify the problem:

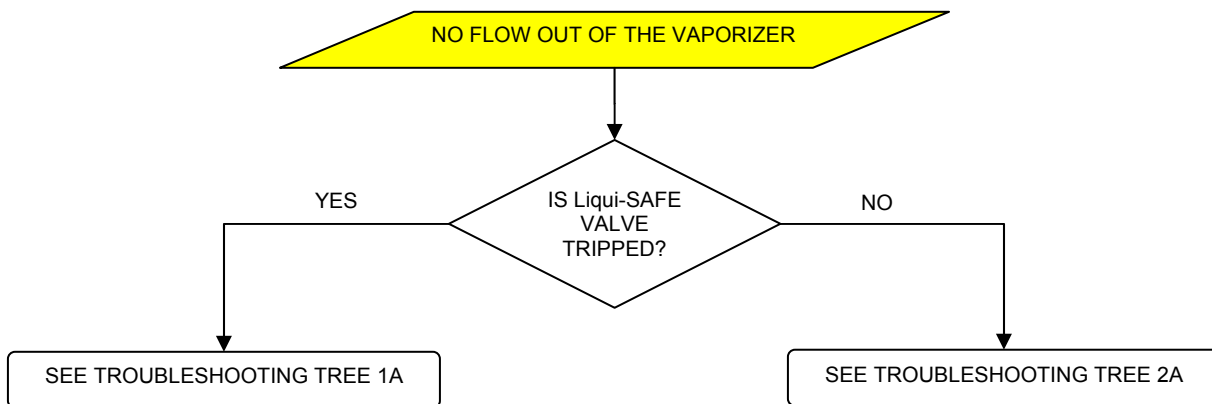

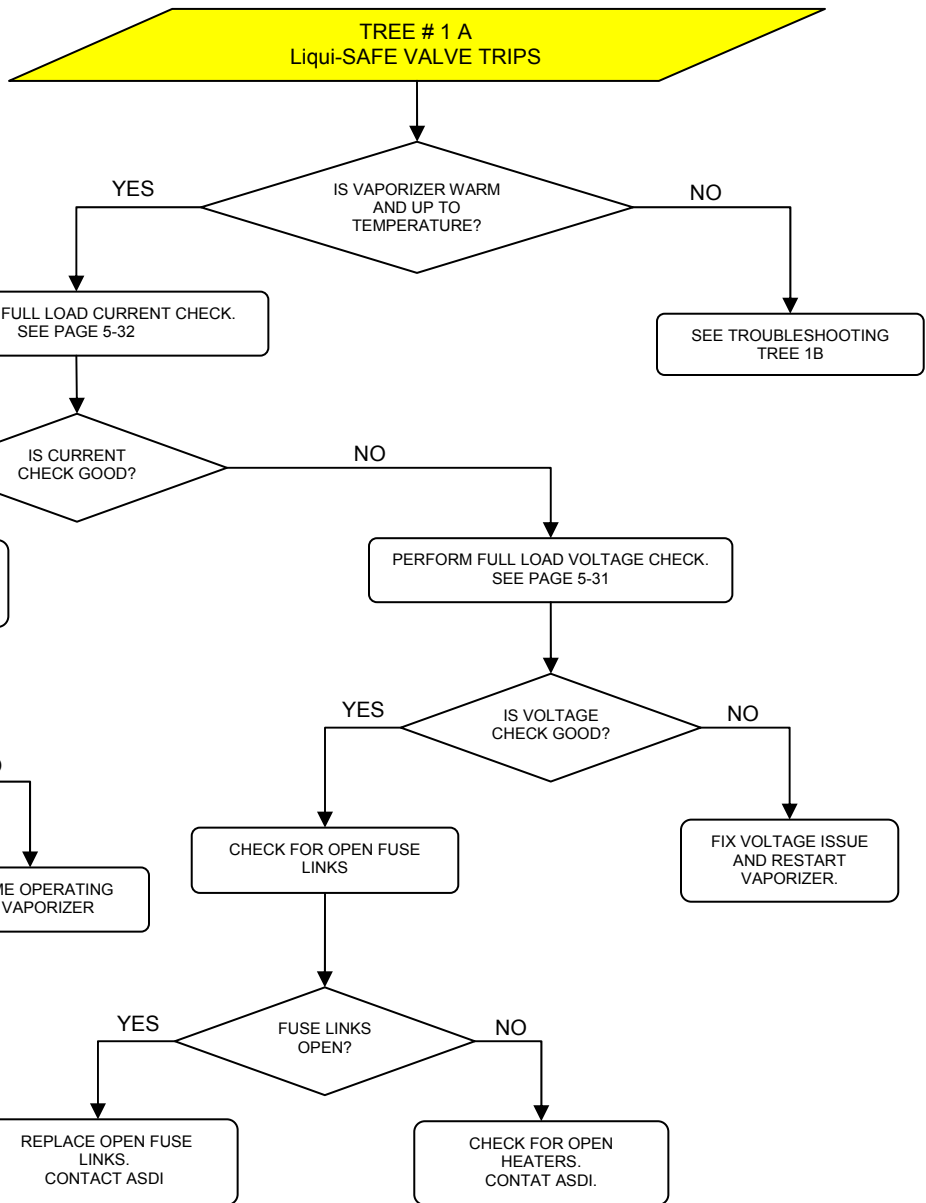

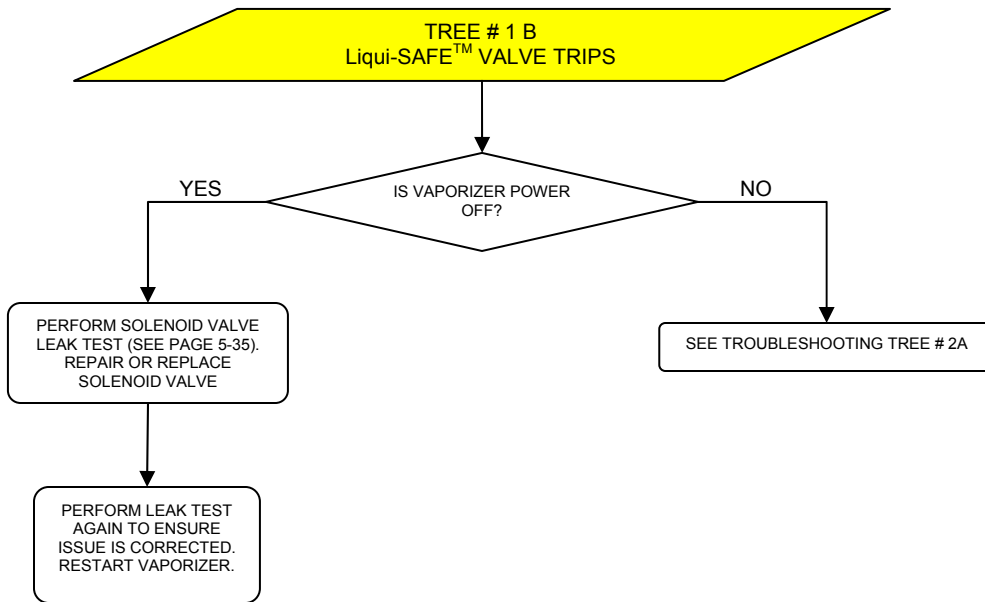

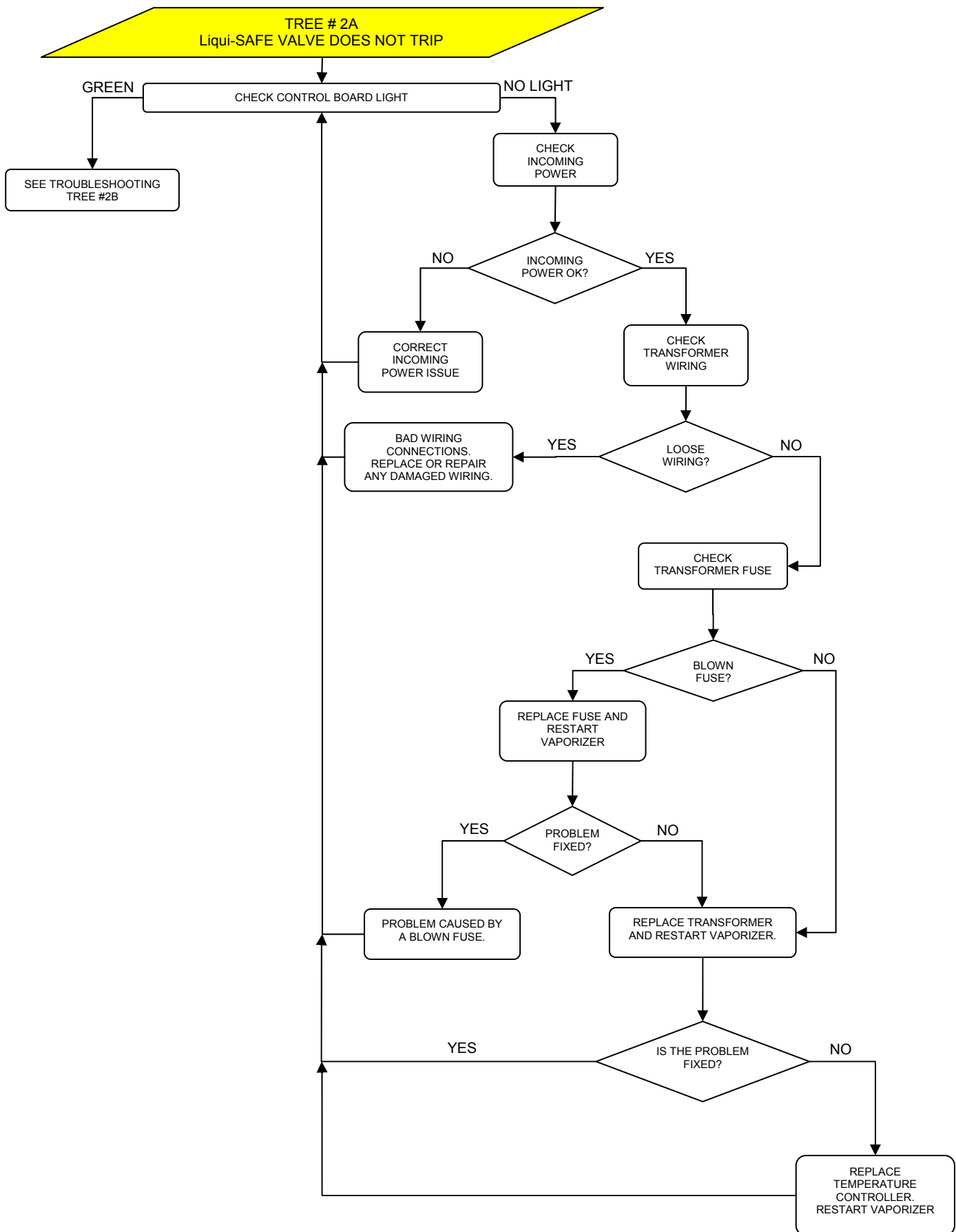

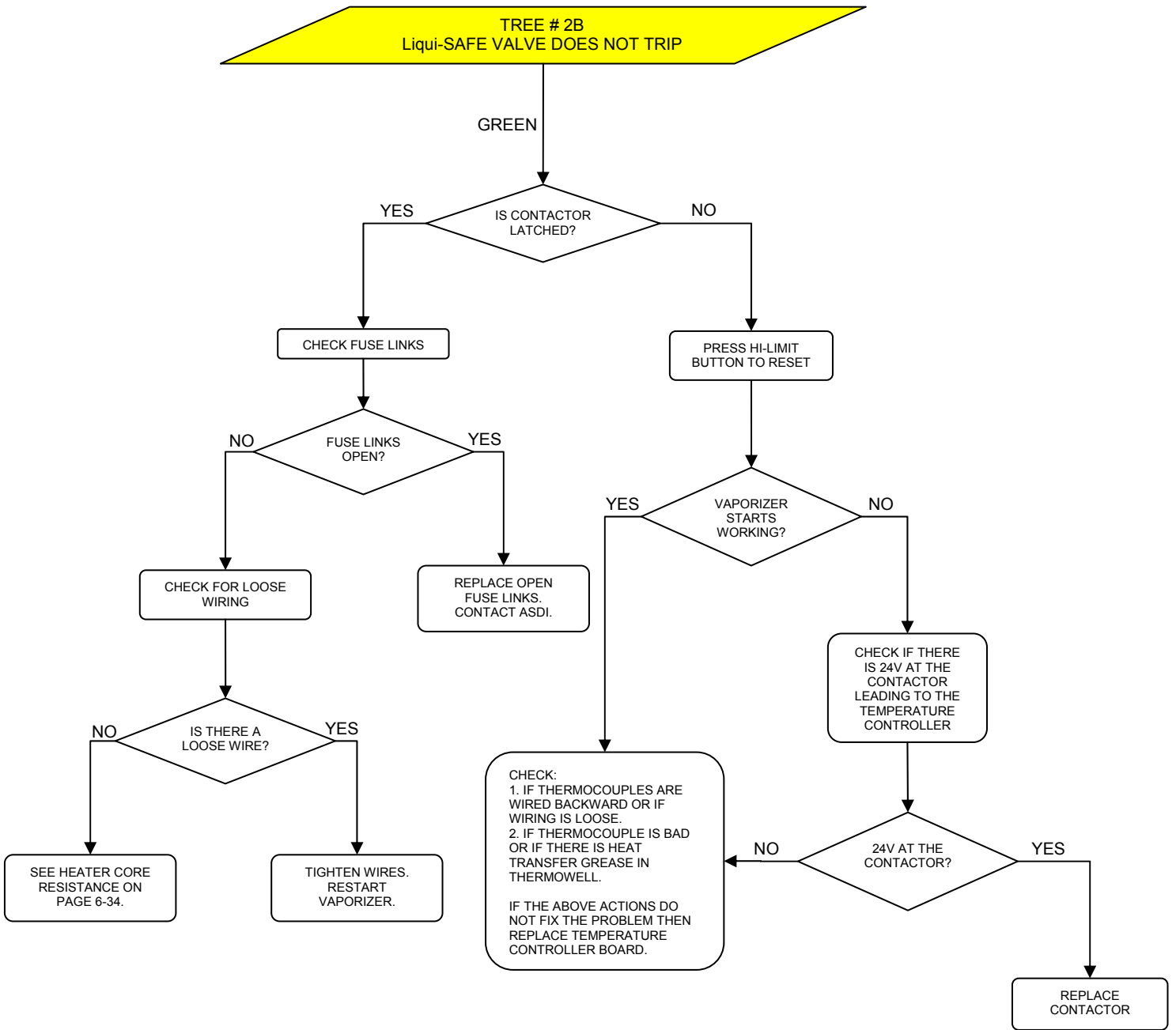

Full Load Voltage Check

NOTE

Current flow depends on the applied voltage. Voltage lower than the specified voltage causes low current and may negatively affect operation. Make all measurements with the heater ON (Contactor closed).

WARNING



These tests include high voltage. Exercise great caution in making the following tests. Carelessness could result in severe injury or death. See additional warnings located at the beginning of this Chapter.

FULL LOAD VOLTAGE CHECK

Check heater voltage by measuring voltage at the contactor terminals. See Data sheet of your manual or rating plate on the vaporizer to determine the correct voltage reading of your vaporizer. Measure voltage between all connected poles of the contactor. The readings should be equal to +/- 3% of the value on the rating plate.

Figure 12 – Full load voltage check

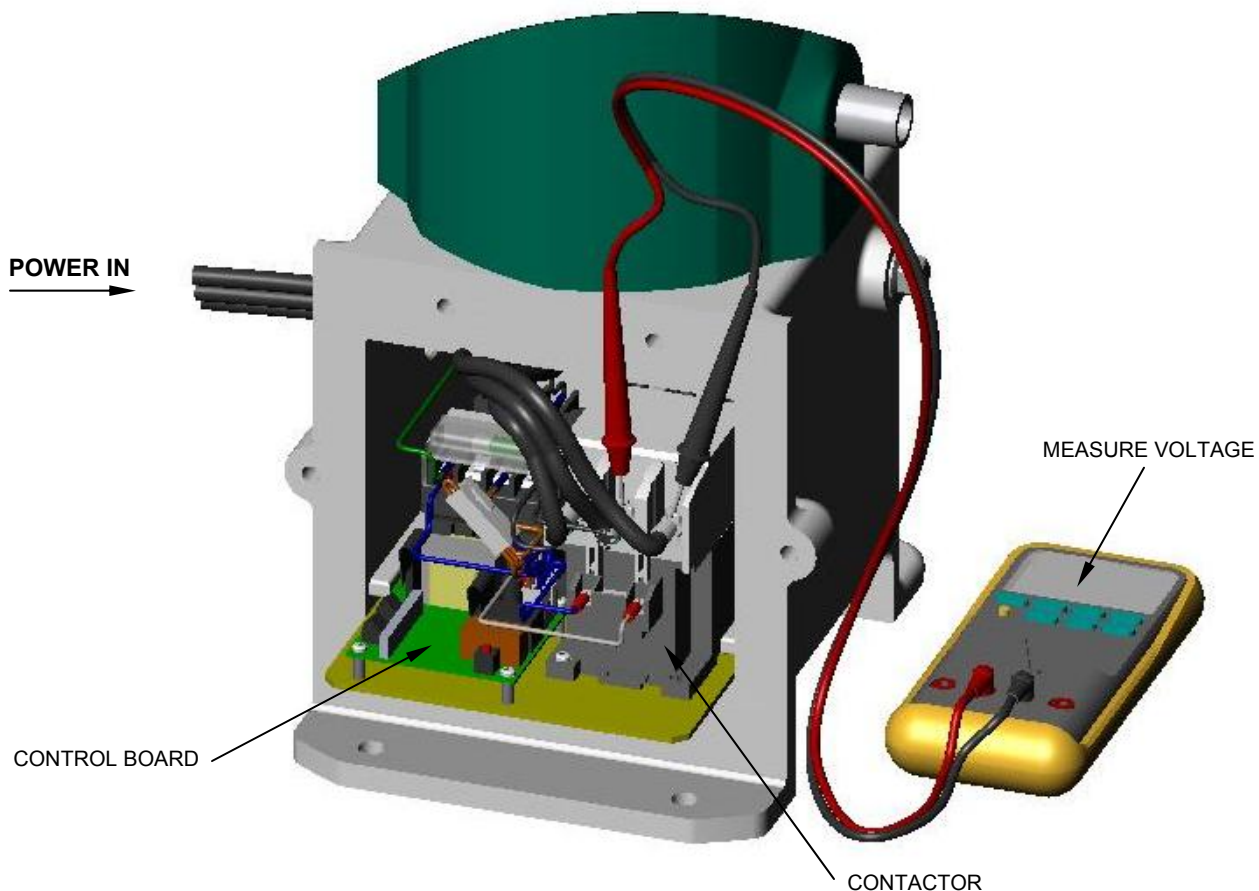

Full Load Current Check

NOTE

See fusible link detail below for typical fusible link installation.

WARNING



These tests include high voltage. Exercise great caution in making the following tests. Carelessness could result in severe injury or death. See additional warnings located at the beginning of this Chapter.

Measure the current on each of the heater AC power input wires. See **Data Sheet or rating plate** provided with your manual for the correct reading (line current) for your vaporizer. All wires should have readings equal to +/- 3% of the value listed on the rating plate.

Low current on all wires indicates low input voltage. Drastically different current readings may indicate a defective heater, defective wiring, or an open fusible link due to overheating. If a fusible link is open, contact the factory. Do not attempt to repair it.

Figure 13 – Full Load Current Check

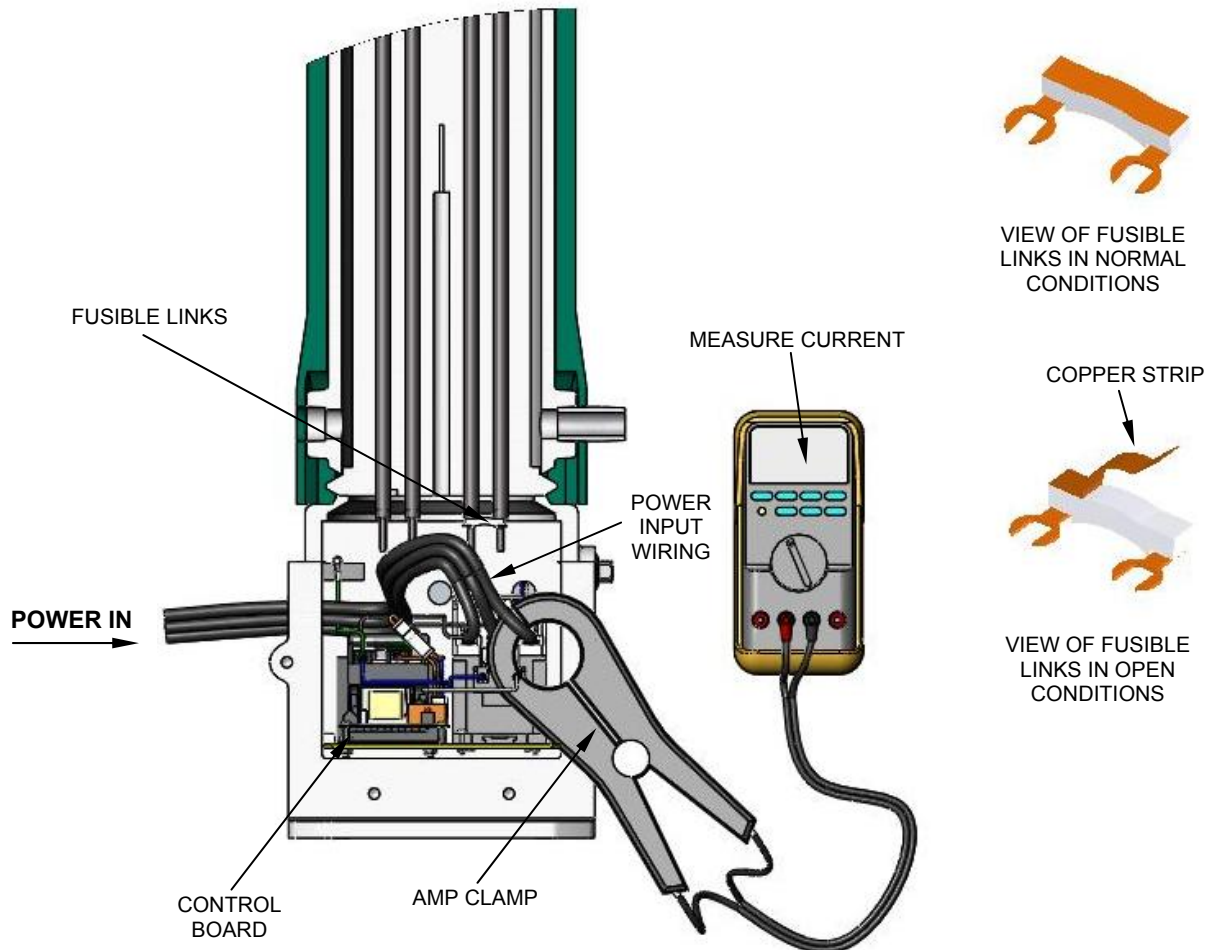

TORREXX Electric Vaporizer Data Sheet

MODEL	PHASE	VOLTAGE (VAC)	CURRENT (A)	HEATER RESISTANCE (OHMS)	WIRE-TO-WIRE RESISTANCE (OHMS)	POWER (kW)
TX25	1	120	32.4	22.2	3.7	3.9
TX25	1	208	14.1	22.2	14.8	2.9
TX25	1	220	14.9	22.2	14.8	3.3
TX25	1	240	16.2	22.2	14.8	3.9
TX50	1	208	28.1	22.2	7.4	5.8
TX50	3	208	16.2	22.2	14.8	5.8
TX50	1	220	29.7	22.2	7.4	6.5
TX50	3	220	17.1	22.2	14.8	6.5
TX50	1	240	32.4	22.2	7.4	7.8
TX50	3	240	18.7	22.2	14.8	7.8
TX50	3	380	9.9	22.2	44.4	6.5
TX50	3	415	10.8	22.2	44.4	7.8
TX100	1	208	56.2	22.2	3.7	11.7
TX100	3	208	32.4	22.2	7.4	11.7
TX100	1	220	59.5	22.2	3.7	13.1
TX100	3	220	34.3	22.2	7.4	13.1
TX100	1	240	54.1	22.2	4.4	13.0
TX100	3	240	37.4	22.2	7.4	15.6
TX100	3	380	19.8	22.2	22.2	13.0
TX100	3	400	20.8	22.2	22.2	14.0
TX100	3	415	21.6	22.2	22.2	15.5
TX100	3	440	17.1	22.2	29.6	13.1
TX100	3	480	18.7	22.2	29.6	15.5
TX160	3	208	49.6	14.5	4.8	17.8
TX160	3	220	52.4	14.5	4.8	20.0
TX160	3	240	51.9	16.0	5.3	21.5
TX160	3	380	30.3	14.5	14.5	19.9
TX160	3	400	28.9	16.0	16.0	20.0
TX160	3	415	30.0	16.0	16.0	21.5
TX160	3	440	26.2	14.5	19.4	20.0
TX160	3	480	26.0	16.0	21.3	21.5
TX240	3	380	45.4	9.7	9.7	29.8
TX240	3	400	47.8	9.7	9.7	33.0
TX240	3	415	49.6	9.7	9.7	35.6
TX240	3	440	39.3	9.7	12.9	29.9
TX240	3	480	42.9	9.7	12.9	35.6
TX320	3	380	50.2	8.8	8.8	33.0
TX320	3	400	36.6	8.8	8.8	37.0
TX320	3	415	54.8	8.8	8.8	39.3
TX320	3	440	43.4	8.8	11.7	33.1
TX320	3	480	47.4	8.8	11.7	39.4
TX 320	3	575	39.2	16.9	17.3	39.0

Heater Core Resistance

NOTE

Refer to the *Bussing diagram in Appendix A* for wire to wire resistance for your vaporizer.

CAUTION

Turn off electrical power at the disconnect before proceeding.



Carefully slide out the control panel for access to the heater wire connections on the contactor. Measure the resistance across each pair of wires. An incorrect resistance reading indicates a faulty heater element, a wiring problem, or an open fusible link.

Figure 14 – Heater Core Resistance Wiring Connections

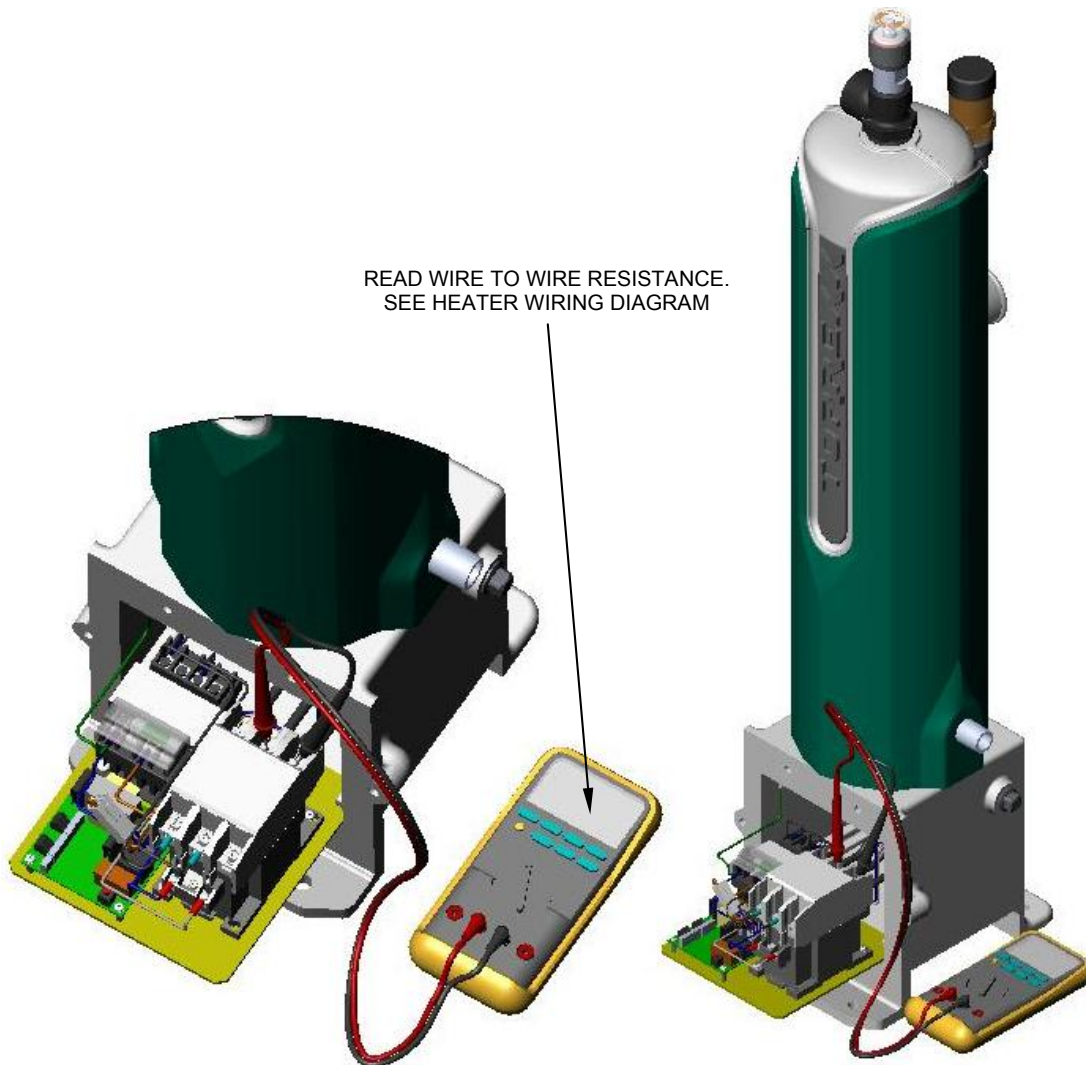

Solenoid Valve Leak Test

- 1) Shut off the outlet isolation valve. The inlet isolation valve should be open. Start the vaporizer and allow it to heat up until the heaters shut off. This allows any accumulated liquid in the vaporizer to be forced back toward the supply tank.
- 2) Disconnect the vaporizer by shutting off the power at the disconnect. Shut off the inlet isolation valve. Cautiously bleed off any LPG pressure in the vaporizer and outlet supply piping. When the pressure reaches no pressure in the vaporizer, remove and then reinstall pressure gauge and verify 0 pressure.
- 3) Turn on the inlet isolation valve. The solenoid valve is closed and you should not have any pressure build up in the vaporizer. If pressure increases, the solenoid valve is leaking and needs to be repaired or replaced.

Figure 15 – Solenoid Valve Leak Test Components

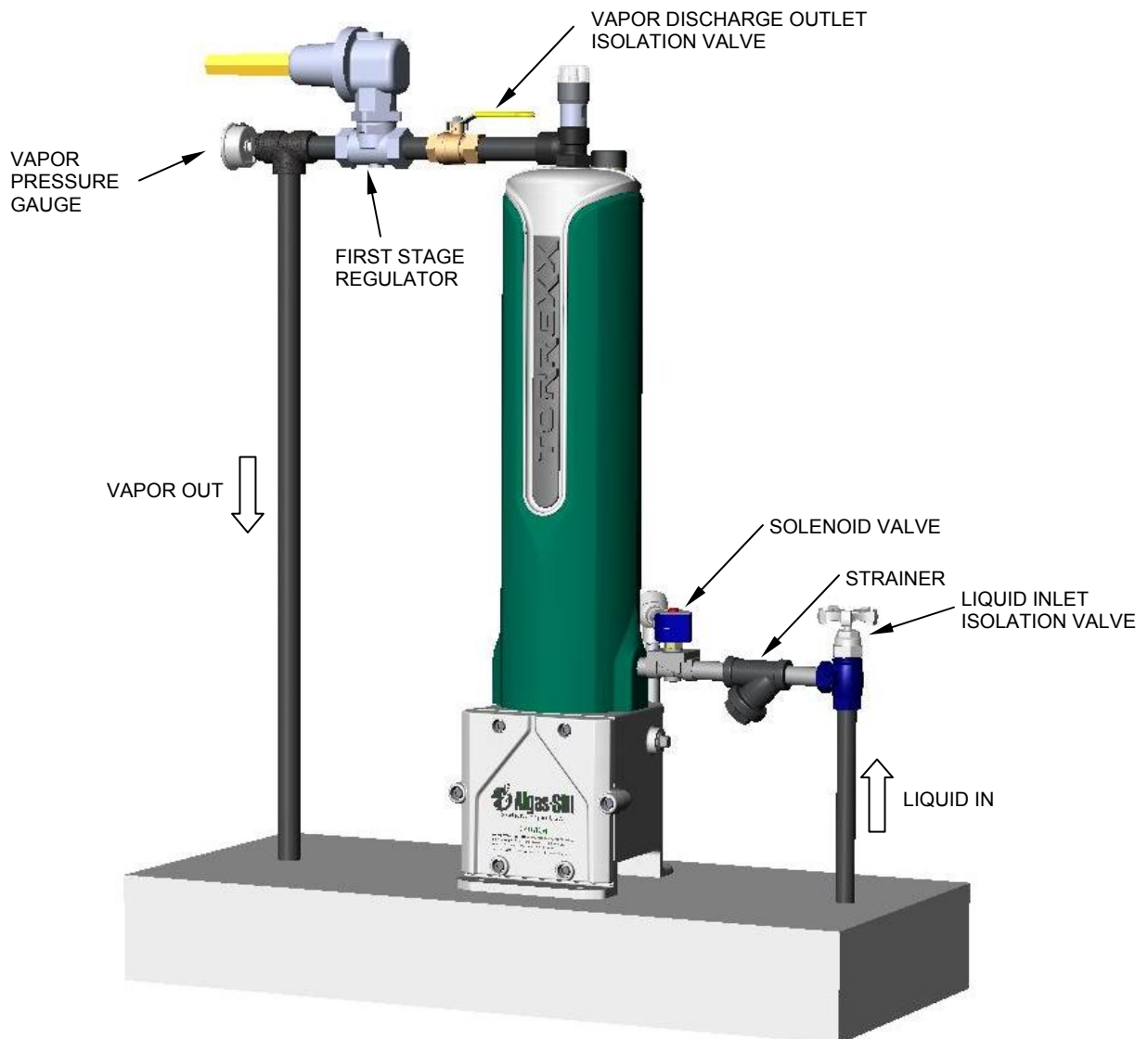

Solenoid Valve Electrical Test

NOTE

A multimeter is required for the following test.

CAUTION

Turn off electrical power at the disconnect before performing this procedure.



Open the electrical housing at the vaporizer base. Disconnect the 2-PIN Molex plug connector and measure resistance between the pins. You should measure approximately 3 ohms. If not, replace the solenoid coil.

Figure 16 – Solenoid Valve Electrical Test

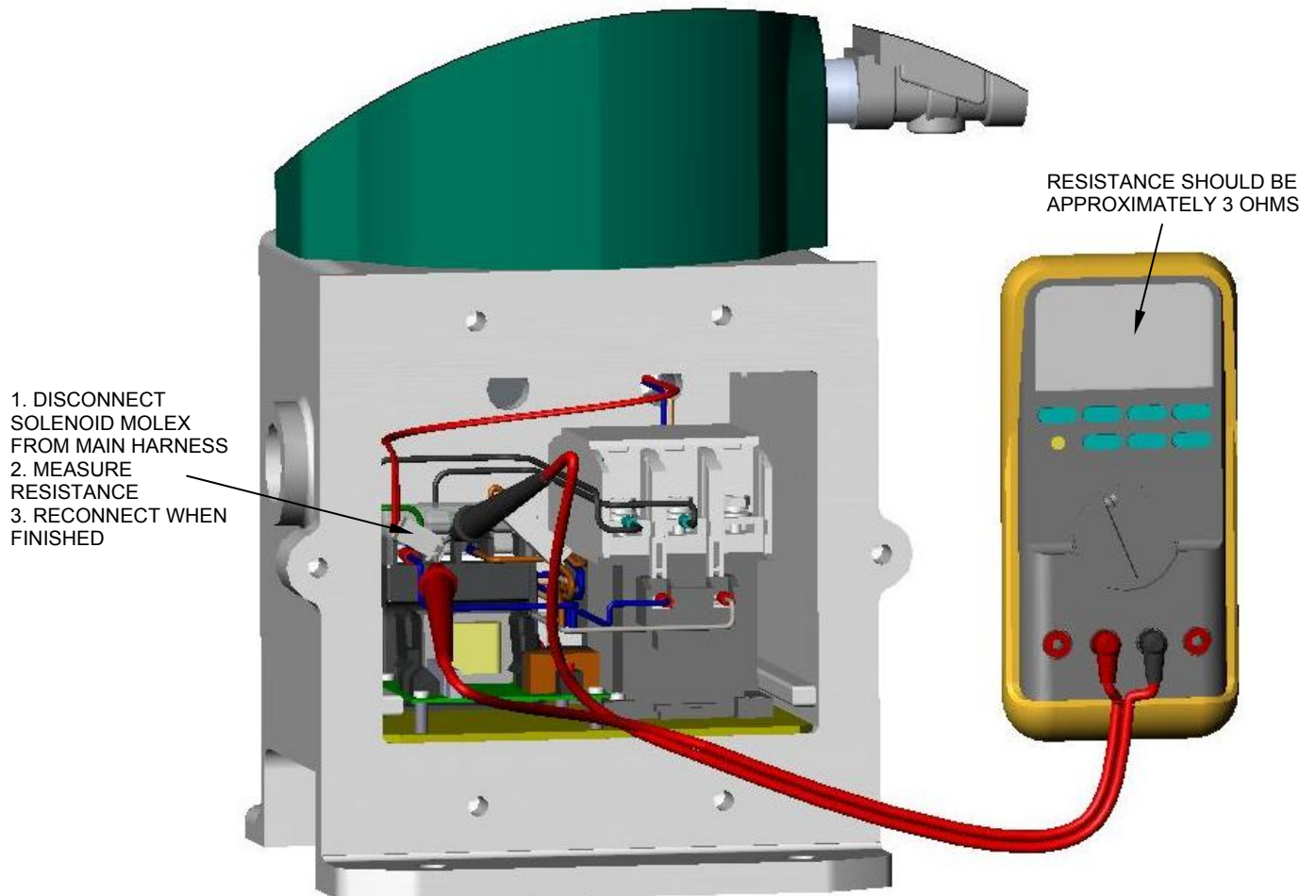

Thermocouple Sensor Replacement

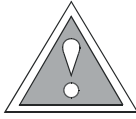

CAUTION

Always disconnect power to vaporizer before servicing.

- 1) Shut off power at the disconnect.
- 2) Remove the control box lid.
- 3) Disconnect the main power wires attached to the contactor and the wires going to the heaters.
- 4) Slide the circuit panel half way out of the control box.
- 5) Disconnect the yellow and red thermocouple wires from control board.
- 6) The thermocouple can now be removed from the center of the core (see Figure 18 and 19). Two types of locking collars have been used on the sensors.

Figure 17 – TORREXX Box showing Thermocouple location

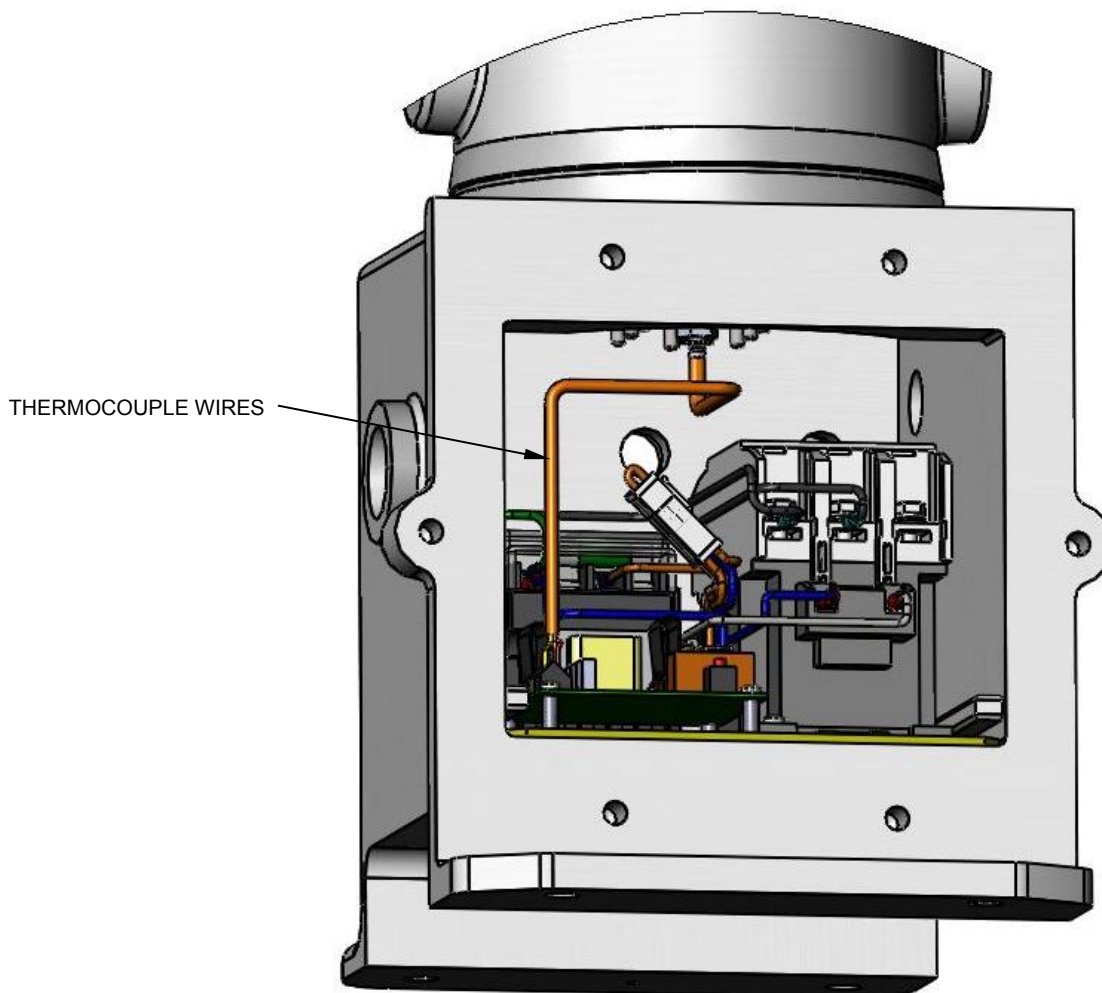
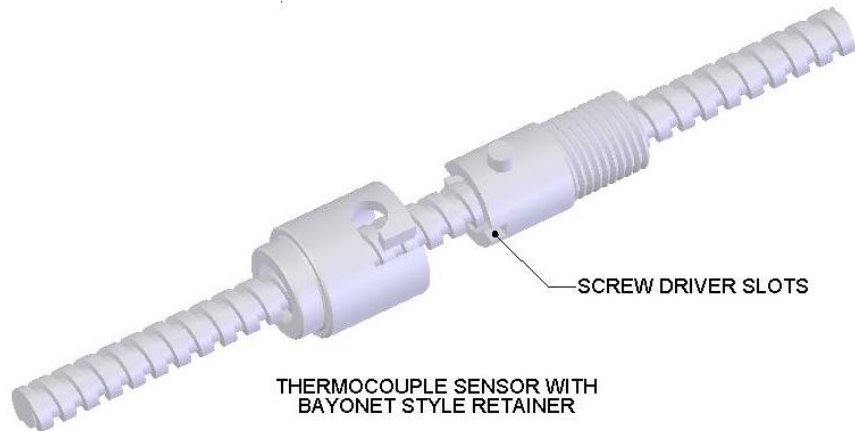

FIGURE 18 – Thermocouple Sensor with Bayonet Style Retainer



- 1) To remove a sensor fitted with the bayonet style retainer, push gently on the retainer while turning to the left. When the retainer is disengaged, pull out the old temperature sensor.
- 2) Use a short, flat-blade screwdriver to remove the adapter.
- 3) Install the new spring tab retainer using an appropriately sized open end wrench (1/2" or 13mm).
- 4) Install the new sensor by applying a small amount of heat transfer grease to the sensor tube and re-inserting in the unit. Squeeze the spring tab while inserting the sensor. Push firmly until the sensor is fully engaged. There should be at least 1/2" of sheath remaining.
- 5) **When connecting new thermocouple wires back to the control board ensure that the yellow wires are connected to the yellow terminals and red wires to the red terminals. Do not over tighten terminal screws!** Connect the main power wires back to the contactor and re-install the control box lid. Torque lid bolts to 19.5 ft-lb. **Failure to properly torque lid bolts may compromise explosion proof enclosure rating and may lead to water entering the enclosure.**
- 6) Restart vaporizer and check operation.

Economy Operation

The Economy Option minimizes the electric power required to meet your vapor demand by shutting off the outlet of the vaporizer when the natural vaporization rate of the storage tank is able to supply enough vapor to meet the demand. A pressure sensing valve is specially developed to sense the upstream pressure. The valve opens when the tank pressure falls below 30PSIG, and closes at 60PSIG. The pressure sensing valve is a mechanical device and it operates independently to the electrical controls.

The Economy Option will **NOT** function if a pump is used.

The pressure set-point of the TORREXX Economy Valve is nonadjustable.

The Economy is normally a factory-installed option. However, a separate Economy valve can be purchased as an add-on in the field.

For the Economy Valve field installation kit, use ASDI PN: 41051.

Make sure that the Economy Valve is correctly installed. Verify the flow direction on the Rating Plate.

Figure 19 – TORREXX Economy valve installation

NOTES

1. LIQUID PIPING LOSSES BETWEEN THE VAPORIZER AND THE TANK MUST NOT EXCEED THE HYDROSTATIC HEAD WHEN THE PUMP IS SHUT OFF
2. INSTALL VAPORIZER 1ST STAGE REGULATOR UPSTREAM OF THE TANK VAPOR PRESSURE CONNECTION POINT.
3. SET 1ST STAGE VAPORIZER REGULATOR 2-4 PSIG HIGHER THAN TANK VAPOR PRESSURE REGULATOR SET-POINT.
4. NO CHECK VALVES IN LIQUID LINE. LIQUID MUST BE ABLE TO FLOW IN BOTH DIRECTIONS.

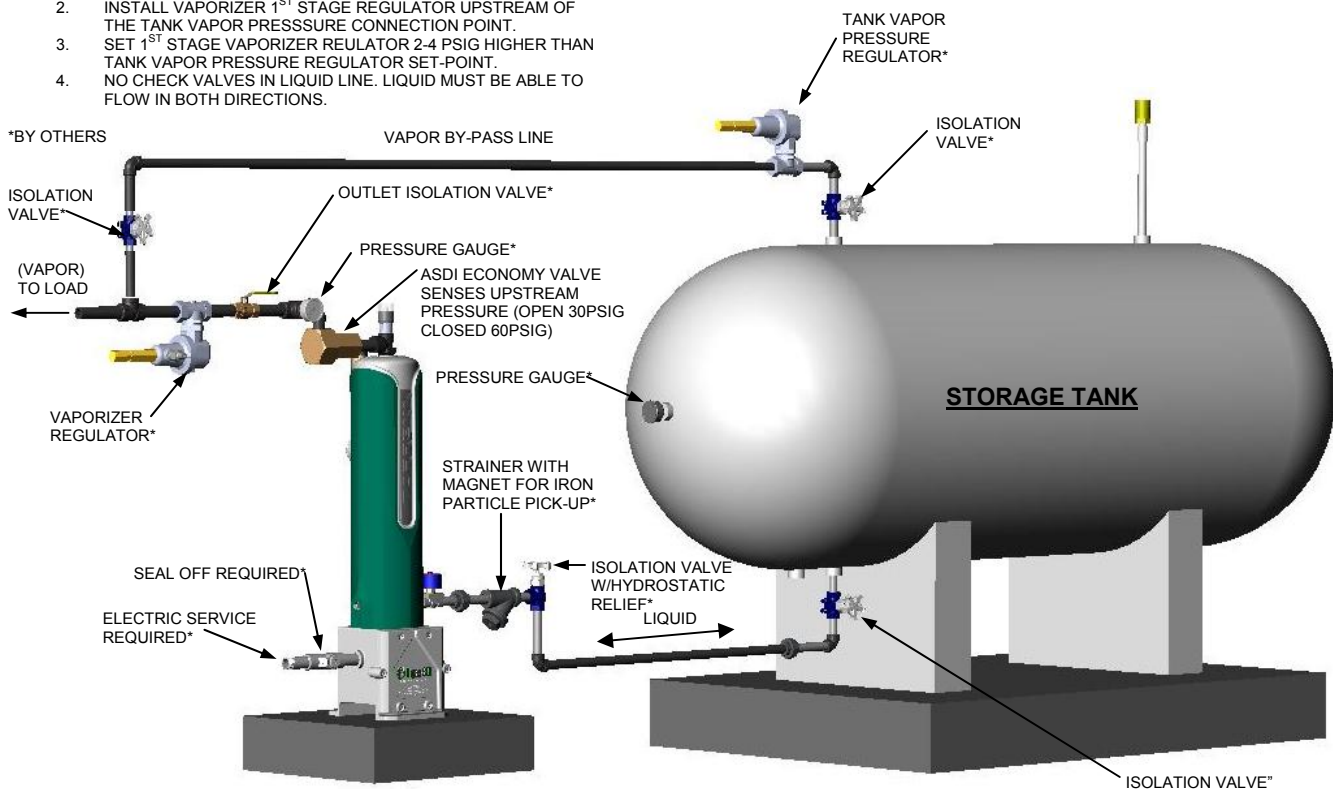

Note: Economy option cannot be used on an installation that requires a pump.

TORREXX Economy Valve Maintenance

TORREXX Economy Valve operates by sensing the pressure of the Vaporizer and Storage Tank. The Economy Valve consists of a moving piston which opens and closes the valve's outlet. The movement of the piston is driven by the pressure force balance between two different sized o-rings and a spring. Follow the instructions below and perform maintenance on the Economy Valve once every two years:

Figure 20A – STEP 1 – Unscrew the Inlet Housing from the Outlet Housing.

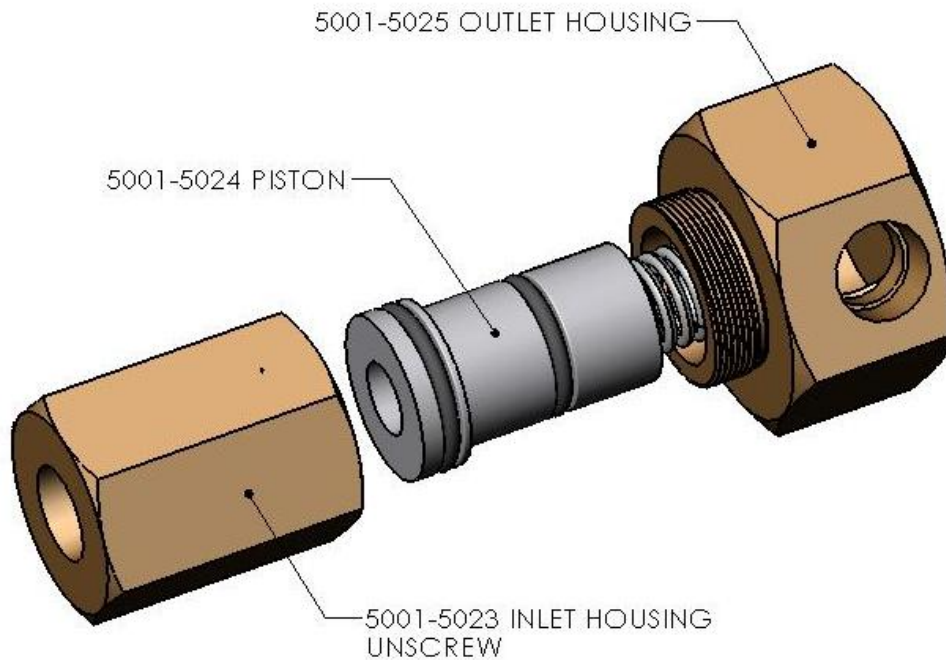

Figure 20B – STEP 2 – Replace the two O-rings (ASDI PN 39012 and 39014). Apply excess lithium o-ring grease.

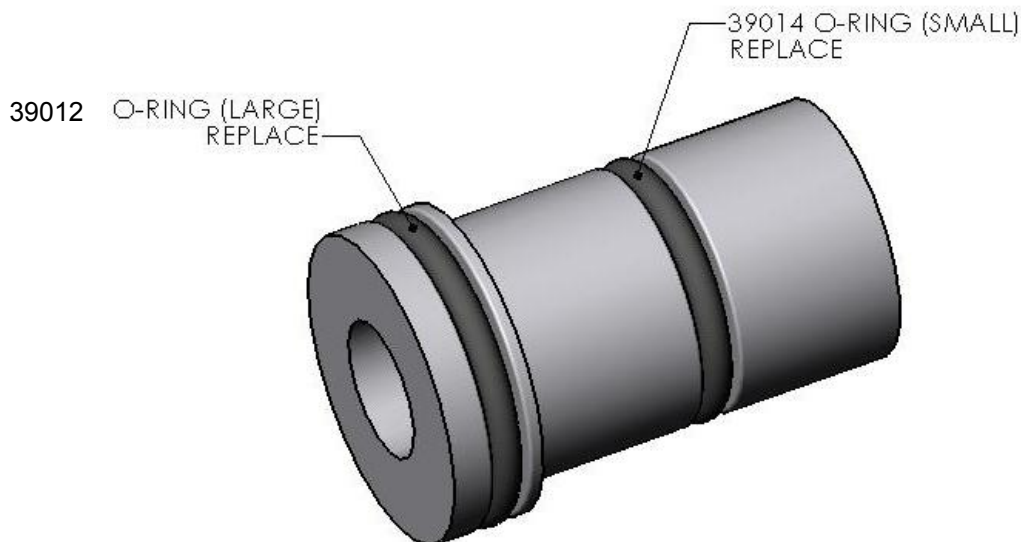

Figure 20C – STEP 3 – Clean all o-ring contact surfaces and the bottom surface of the Outlet Housing. Apply excess lithium o-ring grease.

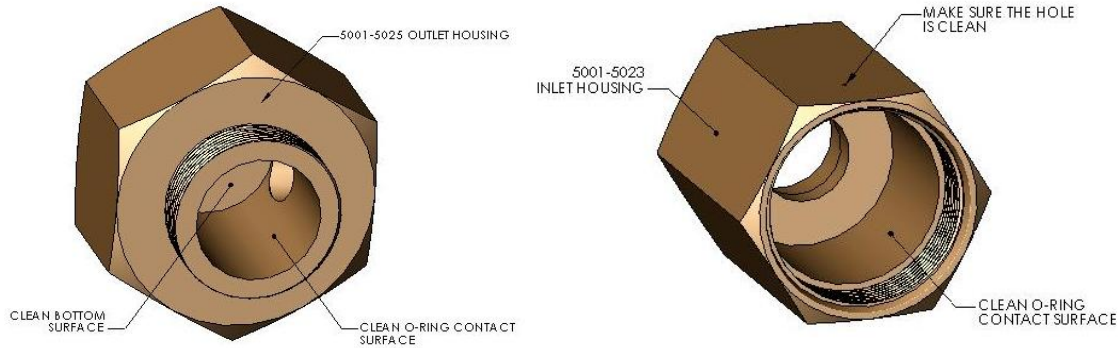

Figure 20D – STEP 4 – Clean all piston surfaces. Apply excess lithium grease on o-rings.

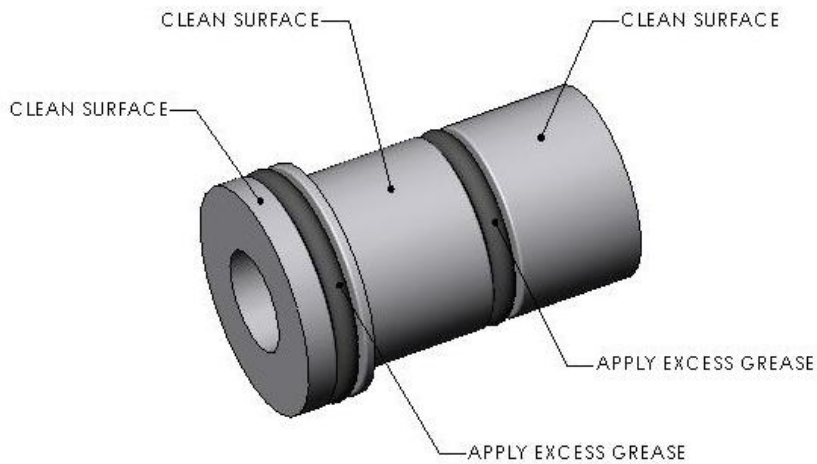
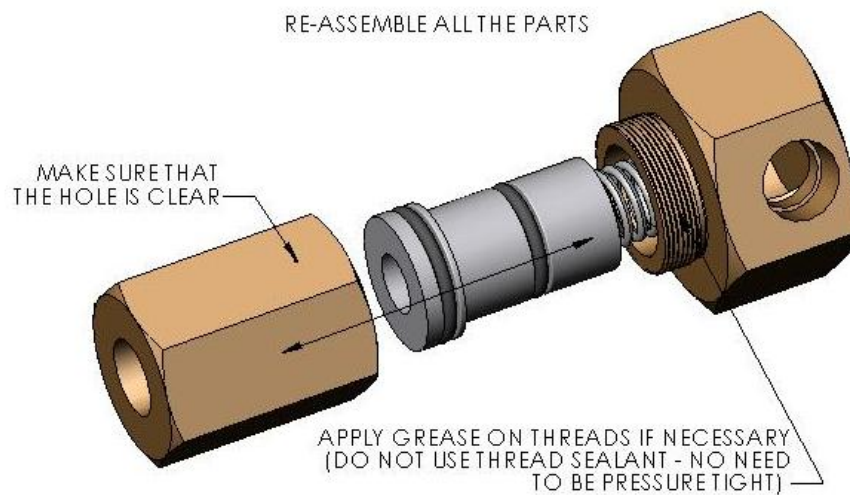

Figure 20E – STEP 5 – Make sure that the Pin Hole is clear and the spring is undamaged. Carefully reassemble all the parts. Apply lubrication grease on the straight threads if necessary.*



* - The threads between the Inlet Housing and the Outlet Housing are straight threads and are designed to be hand tightened. Gas will NOT leak through these threads because of the seals from the two o-rings. However, the Inlet Housing MUST be screwed all the way down for the Valve to accurately function at the set pressure. DO NOT apply sealing agent or Teflon tape on these threads.

Refer to the table below for any replacement parts in the TORREXX Economy Valve.

QUANTITY	ASDI PART NO.	DESCRIPTION
1	5001-5023	INLET HOUSING
1	5001-5025	OUTLET HOUSING
1	5001-5024	VALVE PISTON
1	39012	VALVE O-RING (LARGE)
1	39014	VALVE O-RING (SMALL)
1	39038	VALVE SPRING
1	5001-5026	VALVE RATING PLATE
2	60204	RIVET

Mercury Relay

The life of the vaporizer can be further extended by using a Mercury Relay. Compared to a “dry” contactor, a Mercury Relay reduces the wear and tear each time the heater cycles. A larger explosion-proof enclosure is also used which improves access to the electrical controls.

Mercury Relay is standard on TX240 and TX320 vaporizers in most markets. It is suitable for Class I Division 1 Group D locations and is only available in the NEC configuration. Please contact ASDI if you want to implement this option on TX 160 or want to find out if Mercury Relay option can be used in your market.

The Mercury Relay Option can be integrated with all the other TORREXX options (i.e. Economy, Remote, etc.) In addition, customized options such as external lamps/indicators, on/off switches are also available. Please consult ASDI for details.

TX Remote Box

Includes remote start/stop capability and a status light indicating the vaporizer is ready for operation (solenoid valve open). Connection between the box and the vaporizer is established through the wire harness found on the inside the vaporizer explosion proof enclosure. Remote box is intended for indoor or outdoor installation in general purpose location.

FIGURE 21 – Remote START/STOP box



Valve and Strainer Package

For TX25 to TX320 ASDI PN: 36922 ¾" NPT inlet, 1" NPT outlet

For TX19AA to TX240AA ASDI PN: 36925

Filtaire – Contaminant Separator

The Filtaire is a filtering device designed to trap heavy hydrocarbons commonly present in LPG vapor. It also traps other materials, which may be in the gas due to storage conditions and internal condition of the equipment.

Impurities are collected in the system and periodically removed through the system blow down drain. Residual heavy end hydrocarbons with boiling points higher than pure LPG are trapped by the filter and fall to the bottom for removal.

A complete Filtaire system consists of inlet and outlet connections, a blow-down drain (5), a pressure gauge (4), a vent which is normally plugged (6), and a bypass valve system for cleaning (1, 2, and 3). The bypass valves enable the system to continue operating when the Filtaire is removed for cleaning.

FIGURE 22 – Filtaire Operation

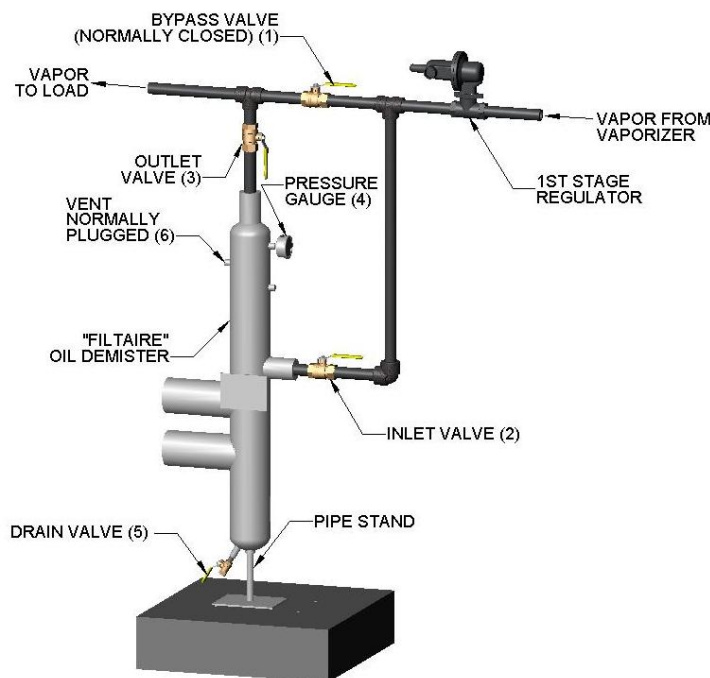

Leak Test

1. Close outlet valve.
2. Slowly open inlet valve and allow pressure to equalize in the vaporizer.
3. Apply a small amount of soap/water solution to ALL pipe connections.
4. Check for any leaks by observing new bubble formation in the soap/water solution.

Repair any leaks before continuing.

APPENDIX A

*TECHNICAL
INFORMATION*



EC Declaration of Conformity

WE, Algas-SDI
151 South Michigan
Seattle, WA 98108 USA

Declare, solely under own responsibility, that the product

Model: TX Series, LPG vaporizer for converting liquefied petroleum to vapor by means of an electric heater/heat exchanger.

Mentioned in this declaration, complies with the following standards and/or normative documents:

Requirements	Remarks	Certificates No.
94/9/EC, Annex VII	Product Quality Assurance ATEX Directive	DNV-2006-OSL-ATEX-0166Q
Notified Body:	Det Norske Veritas AS Veritasveien 1 N-1322 Hovik, Norway	0575
	CE  II 2 G EEx d IIB T3	NEMKO 04ATEX1026X
EN 60079-0:2004	Explosive Atmospheres Equipment – General Requirements	
EN 60079-01:2004	Explosive Atmospheres Equipment Protection by Flameproof Enclosures “d”	
Type Examination Body:	NEMKO P.O. Box 73 Blindern N-0314 OSLO, Norway	0470
97/23/EC	Pressure Equipment Directive Module H	40065-2011-CE-USA-DNV
Technical Standards Applied: ASME B&PV Code, Section VIII, Div. 1		
Notified Body:	Det Norske Veritas AS Veritasveien 1 N-1322 Hovik, Norway	0575



CE Declaration of Conformity Continued:

Requirements	Remarks	Certificates No.
2004/108/EC	EMC Directive	
EN 50081 T2	Electromagnetic Compatibility – Generic Emission Standard	
EN 50082 T2	Electromagnetic Compatibility – Generic Immunity Standard	
EN 61000-4-2	Electrostatic Discharge	
ENV 50140	Radiated Electromagnetic Field	
ENV 50204	Radiated Electromagnetic Field from Digital Radio Telephones	
EN 61000-4-4	Electrical Fast Transient/Burst	
ENV 50141	Conducted Disturbances Induced By Radio-Frequency Fields	
EN 61000-4-8	Power Frequency Magnetic Field Immunity	
Conformity Assessment:	Quest Engineering Solutions 7 Sterling Road, PO Box 125 N. Billerica, MA 01862	US0030

Mike Zimmer, PE
Director of Engineering
February 2, 2012

**TORREXX Vertical Electric Vaporizer Data Sheet
LPG Systems**

Refer to Nameplate on unit for the model and voltage information then look up specific information on the tables below.

General Specifications: Applies to all units

Electrical: 50 – 60 Hz, NEMA 4, 1 Phase units are 2 wire, 3 Phase units are 3 wire

Starting Temperature: 55 Deg. C 131 Deg. F

Operating Temperature: 71-79 Deg. C 160-175 Deg. F

High Temperature Limit: 171 Deg. C 340 Deg. F

Connections: 3/4" FNPT – Inlet; 1" FNPT – Outlet

Conduits: 1" FNPT, Conduit Seal-Off by others

Type of Service: Propane Vaporization

ASME Pressure Vessel: 250 PSIG MAWP @ 250°F
-20°F MDMT @ 250 PSIG

Heat Exchanger Area: 2.9 ft² / 0.269 m² TX25, TX50 and TX100

4.3 ft² / 0.399 m² TX160

5.4 ft² / 0.503 m² TX240

7.1 ft² / 0.660 m² TX320

Dry Weight: 128 lbs / 58.1 kg TX25, TX50 and TX100

145 lbs* / 65.8 kg* TX160

155 lbs* / 70.3 kg* TX240

173 lbs* / 78.5 kg* TX320

* - Add 50 lbs / 22.7 kg if vaporizer if the Mercury Relay option is installed.

Wiring: Meets NFPA Pamphlet 70 requirements for Class I Division 1 Group D

Other: Meets NFPA Pamphlet 58 requirements for electric vaporizers and may be installed per indirect fired vaporizers limitations.



“TORREXX” is a trademark of Algas-SDI International LLC.

TORREXX VERTICAL ELECTRIC VAPORIZER DATA SHEET FOR LPG SYSTEMS

Table: LPG VAPORIZER DATA TABLE

MODEL	PHASE	VOLTAGE	CURRENT Amps.	POWER kW	EQUIPMENT DRAWING	ELECTRICAL DRAWING	BUSSING DIAGRAM
TX-25	1	120	32.4	4	5001 - 6001	5001-7008	0620 - 7007
TX-25	1	208	14.1	3	5001 - 6001	5001-7008	0620 - 7003
TX-25	1	220	14.9	3	5001 - 6001	5001-7008	0620 - 7003
TX-25	1	240	16.2	3	5001 - 6001	5001-7008	0620 - 7003
TX-50	1	208	28.1	6	5001 - 6001	5001-7008	0620 - 7004
TX-50	1	220	29.7	7	5001 - 6001	5001-7008	0620 - 7004
TX-50	1	240	32.4	8	5001 - 6001	5001-7008	0620 - 7004
TX100	1	208	56.2	12	5001 - 6001	5001-7008	0620 - 7007
TX100	1	220	59.5	13	5001 - 6001	5001-7008	0620 - 7007
TX100	1	240	54.1	13	5001 - 6001	5001-7008	0620 - 7008
TX-50	3	208	16.2	6	5001 - 6001	5001-7008	0620 - 7005
TX-50	3	220	17.1	7	5001 - 6001	5001-7008	0620 - 7005
TX-50	3	240	18.7	8	5001 - 6001	5001-7008	0620 - 7005
TX-50	3	380	9.9	7	5001 - 6001	5001-7008	0620 - 7028
TX-50	3	400	10.4	7	5001 - 6001	5001-7008	0620 - 7028
TX-50	3	415	10.8	8	5001 - 6001	5001-7008	0620 - 7028
TX100	3	208	32.4	12	5001 - 6001	5001-7008	0620 - 7009
TX100	3	220	34.3	13	5001 - 6001	5001-7008	0620 - 7009
TX100	3	240	37.4	16	5001 - 6001	5001-7008	0620 - 7009
TX100	3	380	19.8	13	5001 - 6001	5001-7008	0620 - 7010
TX100	3	400	20.8	14	5001 - 6001	5001-7008	0620 - 7010
TX100	3	415	21.6	16	5001 - 6001	5001-7008	0620 - 7010
TX100	3	440	17.1	13	5001 - 6001	5001-7008	0620 - 7011
TX100	3	480	18.7	16	5001 - 6001	5001-7008	0620 - 7011
TX160	3	208	45.0	16	5001 - 6001	5001-7008	0620 - 7009
TX160	3	220	47.6	18	5001 - 6001	5001-7008	0620 - 7009
TX160	3	240	51.9	22	5001 - 6001	5001-7008	0620 - 7012
TX160	3	380	27.5	18	5001 - 6001	5001-7008	0620 - 7010
TX160	3	400	28.9	20	5001 - 6001	5001-7008	0620 - 7010
TX160	3	415	30.0	22	5001 - 6001	5001-7008	0620 - 7010
TX160	3	440	23.8	18	5001 - 6001	5001-7008	0620 - 7011
TX160	3	480	26.0	22	5001 - 6001	5001-7008	0620 - 7011
TX240	3	380	38.1	25	5001 - 6001	5001-7008	0620 - 7010
TX240	3	400	40.1	28	5001 - 6001	5001-7008	0620 - 7010
TX240	3	415	41.6	30	5001 - 6001	5001-7008	0620 - 7010
TX240	3	440	33.0	25	5001 - 6001	5001-7008	0620 - 7011
TX240	3	480	36.0	30	5001 - 6001	5001-7008	0620 - 7011
TX320	3	380	50.2	33	5001 - 6001	5001-7008	0620 - 7010
TX320	3	400	52.8	37	5001 - 6001	5001-7008	0620 - 7010
TX320	3	415	54.8	39	5001 - 6001	5001-7008	0620 - 7010
TX320	3	440	43.5	33	5001 - 6001	5001-7008	0620 - 7011
TX320	3	480	47.4	39	5001 - 6001	5001-7008	0620 - 7011
TX320	3	575	39.2	39	5001 - 6001	5001-7008	0620 - 7010

TORREXX Electric Vaporizer Spare Parts and Accessories

REFERENCE KEY	SPARE PARTS	TX25	TX25	TX50	TX50	TX100
		120V	208V 220V 240V	208V 220V 240V	380V 400V 415V	208V 220V 240V
1	TEMPERATURE CONTROL BOARD	53900	53900	53900	53900	53900
2	TRANSFORMER	52605-01	52606-01	52606-01	52607-01	52606-01
3	CONTACTOR	53630	53630	53630	53630	53630
4	THERMOCOUPLE	5001-4009-01	5001-4009-01	5001-4009-01	5001-4009-01	5001-4009-01
5	Liqui-SAFE VALVE	5001-3003	5001-3003	5001-3003	5001-3003	5001-3003
6	PRESSURE RELIEF VALVE	34876	34876	34876	34876	34876
7	RAIN CAP	35379	35379	35379	35379	35379
8	FUSIBLE LINK	33139	33139	33139	33139	33139
9	INLET SOLENOID	36111	36111	36111	36111	36111
10	FUSE KIT	52222	52222	52222	52222	52222
11	ECONOMY VALVE FIELD INSTALL KIT	41051	41051	41051	41051	41051
12	MERCURY RELAY CONTACTOR	N/A	N/A	N/A	N/A	N/A
13	TRANSFORMER (MERCURY RELAY)	N/A	N/A	N/A	N/A	N/A
14	WIRE HARNESS (MERCURY RELAY)	N/A	N/A	N/A	N/A	N/A
15	PIPE AWAY ADAPTOR	34877	34877	34877	34877	34877
16	VALVE, GAUGE AND STRAINER KIT	36922	36922	36922	36922	36922
17	DRAIN ASSEMBLY	5010-3003	5010-3003	5010-3003	5010-3003	5010-3003
18	STAND	20437	20437	20437	20437	20437
19	WIRE HARNESS (MAIN)	53820	53820	53820	53820	53820
20	CORROSION INHIBITING TAPE	60806	60806	60806	60806	60806
21	INLET SOLENOID KIT	40287	40287	40287	40287	40287
22	Liqui-SAFE VALVE O-RING KIT	40421	40421	40421	40421	40421
23	Remote START/STOP box	41067	41067	41067	41067	41067
24	Balancing orifice	64004	64004	64004	64004	64004

REFERENCE KEY	SPARE PARTS	TX100	TX100	TX160	TX160	TX160
		380V 400V 415V	440V 480V	208V 220V 240V	380V 400V 415V	440V 480V
1	TEMPERATURE CONTROL BOARD	53900	53900	53900	53900	53900
2	TRANSFORMER	52607-01	52608-01	52606-01	52607-01	52608-01
3	CONTACTOR	53630	53630	53630	53630	53630
4	THERMOCOUPLE	5001-4009-01	5001-4009-01	5001-4009-02	5001-4009-02	5001-4009-02
5	Liqui-SAFE VALVE	5001-3003	5001-3003	5001-3003	5001-3003	5001-3003
6	PRESSURE RELIEF VALVE	34876	34876	34876	34876	34876
7	RAIN CAP	35379	35379	35379	35379	35379
8	FUSIBLE LINK	33139	33139	33139	33139	33139
9	INLET SOLENOID	36111	36111	36111	36111	36111
10	FUSE KIT	52222	52222	52222	52222	52222
11	ECONOMY VALVE FIELD INSTALL KIT	41051	41051	41051	41051	41051
12	MERCURY RELAY CONTACTOR	N/A	N/A	N/A	N/A	N/A
13	TRANSFORMER (MERCURY RELAY)	N/A	N/A	N/A	N/A	N/A
14	WIRE HARNESS (MERCURY RELAY)	N/A	N/A	N/A	N/A	N/A
15	PIPE AWAY ADAPTOR	34877	34877	34877	34877	34877
16	VALVE, GAUGE AND STRAINER KIT	36922	36922	36922	36922	36922
17	DRAIN ASSEMBLY	5010-3003	5010-3003	5010-3003	5010-3003	5010-3003
18	STAND	20437	20437	20437	20437	20437
19	WIRE HARNESS (MAIN)	53820	53820	53820	53820	53820
20	CORROSION INHIBITING TAPE	60806	60806	60806	60806	60806
21	INLET SOLENOID KIT	40287	40287	40287	40287	40287
22	Liqui-SAFE VALVE O-RING KIT	40421	40421	40421	40421	40421
23	Remote START/STOP box	41067	41067	41067	41067	41067
24	Balancing orifice	64004	64004	64004	64004	64004

REFERENCE KEY	SPARE PARTS	TX240	TX240	TX320	TX320
		380V	440V	380V	440V
		400V	480V	400V	480V
		415V		415V	575V
1	TEMPERATURE CONTROL BOARD	53900	53900	53900	53900
2	TRANSFORMER	52607-01	52608-01	52607-01	52608-01
3	CONTACTOR	53630	53630	53630	53630
4	THERMOCOUPLE	5001-4009-03	5001-4009-03	5001-4009-04	5001-4009-04
5	Liqui-SAFE VALVE	5001-3003	5001-3003	5001-3003	5001-3003
6	PRESSURE RELIEF VALVE	34876	34876	34876	34876
7	RAIN CAP	35379	35379	35379	35379
8	FUSIBLE LINK	33139	33139	33139	33139
9	INLET SOLENOID	36111	36111	36111	36111
10	FUSE KIT	52222	52222	52222	52222
11	ECONOMY VALVE FIELD INSTALL KIT	41051	41051	41051	41051
12	MERCURY RELAY CONTACTOR	53324	53324	53324	53324
13	TRANSFORMER (MERCURY RELAY)	52607-01	52608-01	52607-01	52608-01
14	WIRE HARNESS (MERCURY RELAY)	52823	52823	52823	52823
15	PIPE AWAY ADAPTOR	34877	34877	34877	34877
16	VALVE, GAUGE AND STRAINER KIT	36922	36922	36922	36922
17	DRAIN ASSEMBLY	5010-3003	5010-3003	5010-3003	5010-3003
18	STAND	20437	20437	20437	20437
19	WIRE HARNESS (MAIN)	53820	53820	53820	53820
20	CORROSION INHIBITING TAPE	60806	60806	60806	60806
21	INLET SOLENOID KIT	40287	40287	40287	40287
22	Liqui-SAFE VALVE O-RING KIT	40421	40421	40421	40421
23	Remote START/STOP box	41067	41067	41067	41067
24	Balancing orifice	64004	64004	64004	64004

FIGURE 22 – TORREXX electric vaporizer major components and accessories

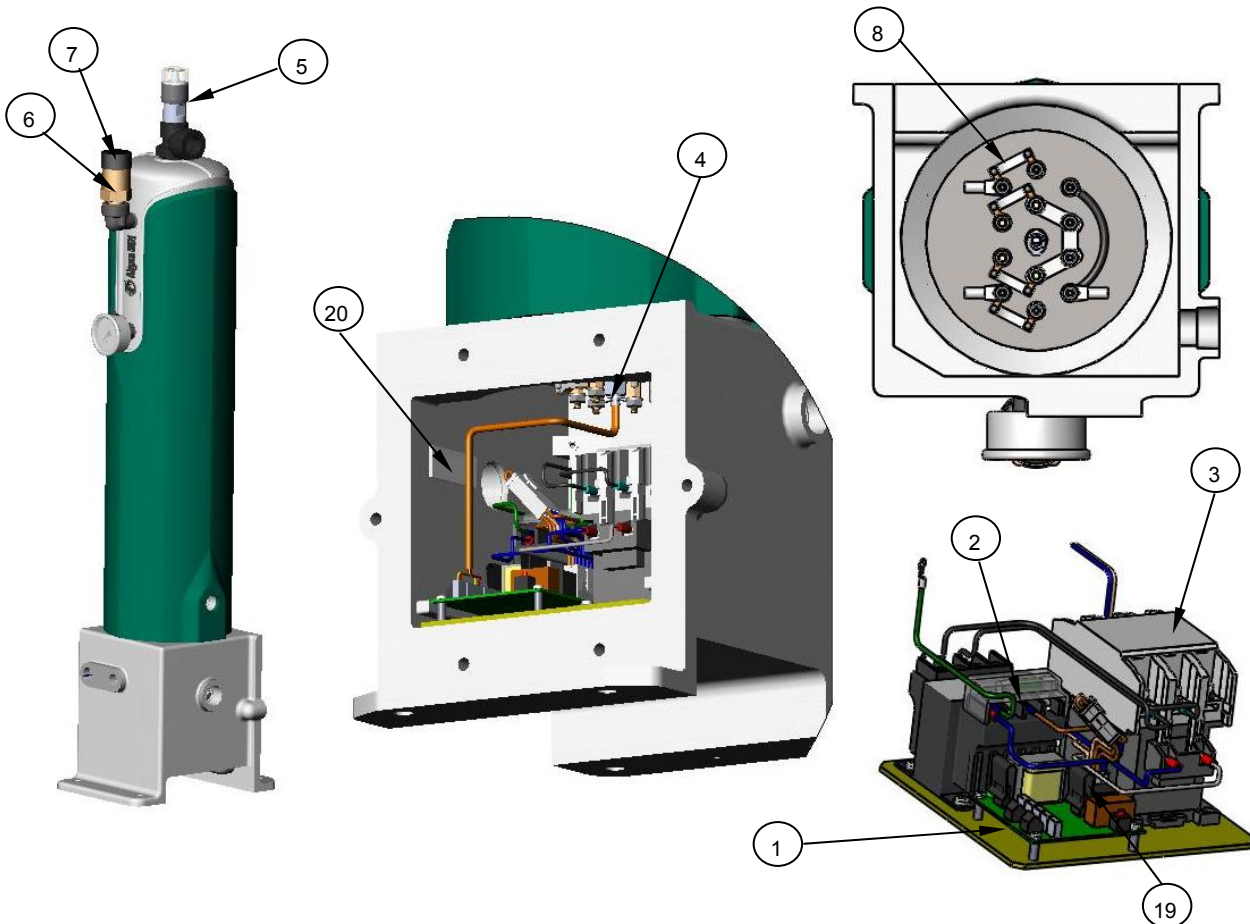

TORREXX Vertical Electric Vaporizer Data Sheet
NEMKO LPG Systems

Refer to Nameplate on unit for the model and voltage information then look up specific information on the tables below.

General Specifications: Applies to all units

Electrical: 50 – 60 Hz, NEMA 4, 1 Phase units are 2 wire, 3 Phase units are 3 wire

Starting Temperature: 55 Deg. C 131 Deg. F

Operating Temperature: 71-79 Deg. C 160-175 Deg. F

High Temperature Limit: 171 Deg. C 340 Deg. F

Connections: ¾" FNPT – Inlet; 1" FNPT – Outlet

Conduits: 1" FNPT, Conduit Seal-Off by others

Type of Service: Propane Vaporization

ASME Pressure Vessel: 250 PSIG MAWP @ 250°F
-20°F MDMT @ 250 PSIG

Heat Exchanger Area: 2.9 ft² / 0.269 m² TX25, TX50 and TX100

4.3 ft² / 0.399 m² TX160

5.4 ft² / 0.503 m² TX240

7.1 ft² / 0.660 m² TX320

Dry Weight: 128 lbs / 58.1 kg TX25, TX50 and TX100

145 lbs / 65.8 kg TX160

155 lbs / 70.3 kg TX240

173 lbs / 78.5 kg TX320

Hazardous Area Rating: NEMKO 04 ATEX 1026X

EEx d IIB T3

TO AVOID POTENTIAL ELECTROSTATIC CHARGING HAZARD, ALWAYS USE A DAMP CLOTH FOR CLEANING THE INSULATION JACKET. AVOID DRY RUBBING OF THE INSULATION JACKET.



“TORREXX” is a trademark of Algas-SDI International LLC.

TORREXX VERTICAL ELECTRIC VAPORIZER DATA SHEET FOR LPG SYSTEMS (NEMKO)

Table: NEMKO LPG VAPORIZER DATA TABLE

MODEL	PHASE	VOLTAGE	CURRENT Amps.	POWER kW	EQUIPMENT DRAWING	ELECTRICAL DRAWING	BUSSING DIAGRAM
TX-25	1	220	14.9	3	5001 - 6003	5001-7008	0620 - 7003
TX-25	1	240	16.2	3	5001 - 6003	5001-7008	0620 - 7003
TX-50	1	220	29.7	7	5001 - 6003	5001-7008	0620 - 7004
TX-50	1	240	32.4	8	5001 - 6003	5001-7008	0620 - 7004
TX100	1	220	59.5	13	5001 - 6003	5001-7008	0620 - 7007
TX100	1	240	54.1	13	5001 - 6003	5001-7008	0620 - 7008
TX-50	3	220	17.1	7	5001 - 6003	5001-7008	0620 - 7005
TX-50	3	240	18.7	8	5001 - 6003	5001-7008	0620 - 7005
TX-50	3	380	9.9	7	5001 - 6003	5001-7008	0620 - 7028
TX-50	3	400	10.4	7	5001 - 6003	5001-7008	0620 - 7028
TX-50	3	415	10.8	8	5001 - 6003	5001-7008	0620 - 7028
TX100	3	220	34.3	13	5001 - 6003	5001-7008	0620 - 7009
TX100	3	240	37.4	16	5001 - 6003	5001-7008	0620 - 7009
TX100	3	380	19.8	13	5001 - 6003	5001-7008	0620 - 7010
TX100	3	400	20.8	14	5001 - 6003	5001-7008	0620 - 7010
TX100	3	415	21.6	16	5001 - 6003	5001-7008	0620 - 7010
TX160	3	220	47.6	18	5001 - 6003	5001-7008	0620 - 7009
TX160	3	240	51.9	22	5001 - 6003	5001-7008	0620 - 7012
TX160	3	380	27.5	18	5001 - 6003	5001-7008	0620 - 7010
TX160	3	400	28.9	20	5001 - 6003	5001-7008	0620 - 7010
TX160	3	415	30.0	22	5001 - 6003	5001-7008	0620 - 7010
TX240	3	380	45.4	30	5001 - 6003	5001-7008	0620 - 7010
TX240	3	400	47.8	33	5001 - 6003	5001-7008	0620 - 7010
TX240	3	415	49.6	36	5001 - 6003	5001-7008	0620 - 7010
TX320	3	380	50.2	33	5001 - 6003	5001-7008	0620 - 7010
TX320	3	400	52.8	37	5001 - 6003	5001-7008	0620 - 7010
TX320	3	415	54.8	39	5001 - 6003	5001-7008	0620 - 7010

TORREXX Electric Vaporizer Spare Parts and Accessories (NEMKO)

REFERENCE KEY	SPARE PARTS	TX25	TX25	TX50	TX50	TX100
		120V	208V 220V 240V	208V 220V 240V	380V 400V 415V	208V 220V 240V
1	TEMPERATURE CONTROL BOARD	53900	53900	53900	53900	53900
2	TRANSFORMER	52605-01	52606-01	52606-01	52607-01	52606-01
3	CONTACTOR	53630	53630	53630	53630	53630
4	THERMOCOUPLE	5001-4009-01	5001-4009-01	5001-4009-01	5001-4009-01	5001-4009-01
5	Liqui-SAFE VALVE	5001-3003	5001-3003	5001-3003	5001-3003	5001-3003
6	PRESSURE RELIEF VALVE	34876	34876	34876	34876	34876
7	RAIN CAP	35379	35379	35379	35379	35379
8	FUSIBLE LINK	33139	33139	33139	33139	33139
9	INLET SOLENOID	33418	33418	33418	33418	33418
10	FUSE KIT	52222	52222	52222	52222	52222
11	ECONOMY VALVE FIELD INSTALL KIT	41051	41051	41051	41051	41051
12	PIPE AWAY ADAPTOR	34877	34877	34877	34877	34877
13	VALVE, GAUGE AND STRAINER KIT	36922	36922	36922	36922	36922
14	DRAIN ASSEMBLY	5010-3003	5010-3003	5010-3003	5010-3003	5010-3003
15	STAND	20437	20437	20437	20437	20437
16	WIRE HARNESS (MAIN)	53820	53820	53820	53820	53820
17	CORROSION INHIBITING TAPE	60806	60806	60806	60806	60806
18	INLET SOLENOID KIT	40249	40249	40249	40249	40249
19	Liqui-SAFE VALVE O-RING KIT	40421	40421	40421	40421	40421
20	Remote START/STOP box	41067	41067	41067	41067	41067
21	Balancing orifice	64004	64004	64004	64004	64004

REFERENCE KEY	SPARE PARTS	TX100	TX100	TX160	TX160	TX160
		380V 400V 415V	440V 480V	208V 220V 240V	380V 400V 415V	440V 480V
1	TEMPERATURE CONTROL BOARD	53900	53900	53900	53900	53900
2	TRANSFORMER	52607-01	52608-01	52606-01	52607-01	52608-01
3	CONTACTOR	53630	53630	53630	53630	53630
4	THERMOCOUPLE	5001-4009-01	5001-4009-01	5001-4009-02	5001-4009-02	5001-4009-02
5	Liqui-SAFE VALVE	5001-3003	5001-3003	5001-3003	5001-3003	5001-3003
6	PRESSURE RELIEF VALVE	34876	34876	34876	34876	34876
7	RAIN CAP	35379	35379	35379	35379	35379
8	FUSIBLE LINK	33139	33139	33139	33139	33139
9	INLET SOLENOID	33418	33418	33418	33418	33418
10	FUSE KIT	52222	52222	52222	52222	52222
11	ECONOMY VALVE FIELD INSTALL KIT	41051	41051	41051	41051	41051
12	PIPE AWAY ADAPTOR	34877	34877	34877	34877	34877
13	VALVE, GAUGE AND STRAINER KIT	36922	36922	36922	36922	36922
14	DRAIN ASSEMBLY	5010-3003	5010-3003	5010-3003	5010-3003	5010-3003
15	STAND	20437	20437	20437	20437	20437
16	WIRE HARNESS (MAIN)	53820	53820	53820	53820	53820
17	CORROSION INHIBITING TAPE	60806	60806	60806	60806	60806
18	INLET SOLENOID KIT	40249	40249	40249	40249	40249
19	Liqui-SAFE VALVE O-RING KIT	40421	40421	40421	40421	40421
20	Remote START/STOP box	41067	41067	41067	41067	41067
21	Balancing orifice	64004	64004	64004	64004	64004

REFERENCE KEY	SPARE PARTS	TX240	TX240	TX320	TX320
		380V	440V	380V	440V
		400V	480V	400V	480V
		415V		415V	575V
1	TEMPERATURE CONTROL BOARD	53900	53900	53900	53900
2	TRANSFORMER	52607-01	52608-01	52607-01	52608-01
3	CONTACTOR	53630	53630	53630	53630
4	THERMOCOUPLE	5001-4009-03	5001-4009-03	5001-4009-04	5001-4009-04
5	Liqui-SAFE VALVE	5001-3003	5001-3003	5001-3003	5001-3003
6	PRESSURE RELIEF VALVE	34876	34876	34876	34876
7	RAIN CAP	35379	35379	35379	35379
8	FUSIBLE LINK	33139	33139	33139	33139
9	INLET SOLENOID	36111	36111	36111	36111
10	FUSE KIT	52222	52222	52222	52222
11	ECONOMY VALVE FIELD INSTALL KIT	41051	41051	41051	41051
12	PIPE AWAY ADAPTOR	34877	34877	34877	34877
13	VALVE, GAUGE AND STRAINER KIT	36922	36922	36922	36922
14	DRAIN ASSEMBLY	5010-3003	5010-3003	5010-3003	5010-3003
15	STAND	20437	20437	20437	20437
16	WIRE HARNESS (MAIN)	53820	53820	53820	53820
17	CORROSION INHIBITING TAPE	60806	60806	60806	60806
18	INLET SOLENOID KIT	40249	40249	40249	40249
19	Liqui-SAFE VALVE O-RING KIT	40421	40421	40421	40421
20	Remote START/STOP box	41067	41067	41067	41067
21	Balancing orifice	64004	64004	64004	64004

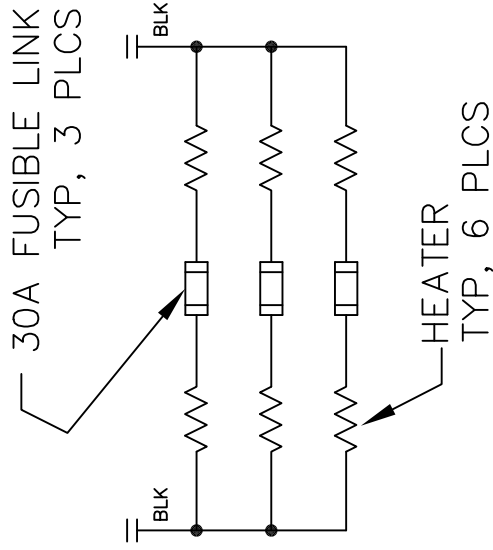
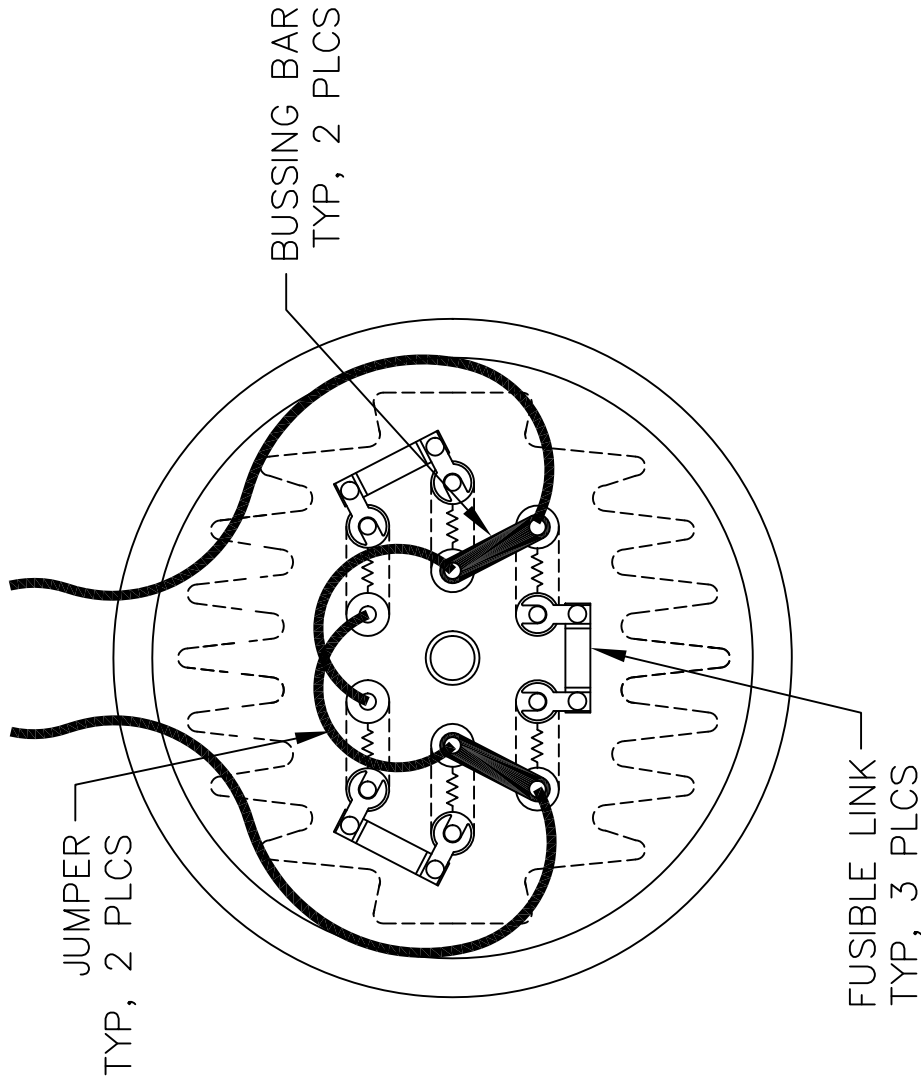

NOTE: CAPACITY FOLLOWED BY "AA" DENOTES AMMONIA CAPACITIES.

CAPACITY SIZE	VOLTAGE	HEATER	INDIVIDUAL HEATER OHMS	WIRE TO WIRE RESISTANCE
LPG				
25	200V/208V/220V/ 240V, 1PH	2595 WATTS @ 240VAC	22.2 OHMS	14.8 OHMS

1 CAPACITY SIZES SHOWN ARE IN KG/HR FOR LPG AND LB/HR FOR NH3 (AA)

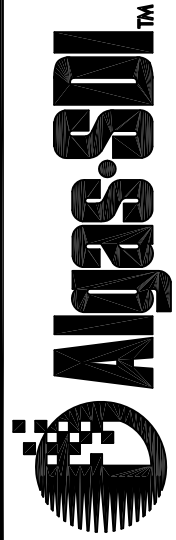

151 S. Michigan St., Seattle, Washington, USA 98108
 Tel: (206) 789-5410 Fax: (206) 789-5414

Title

BUSSING DIAGRAM

CAPACITY SIZE 25 & 19AA
 200V/208V/220V/240V, 1 PH
 TORREX ELECTRIC VAPORIZER
 (REFERENCE 0620-7003A1D)

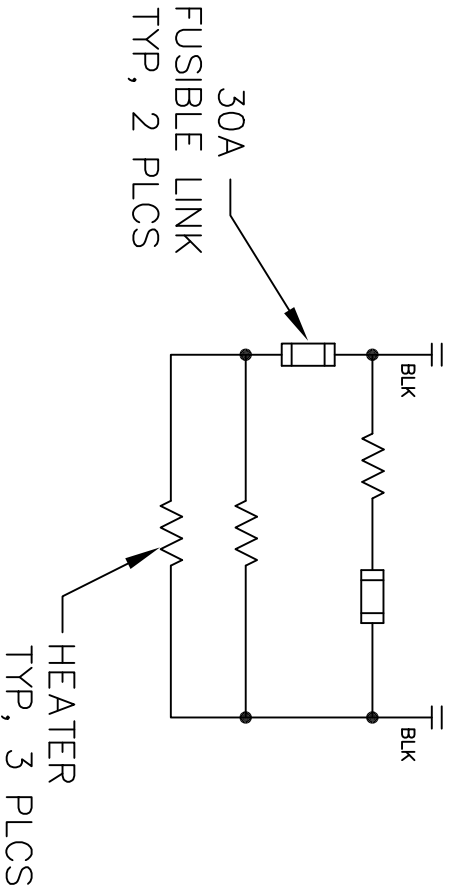
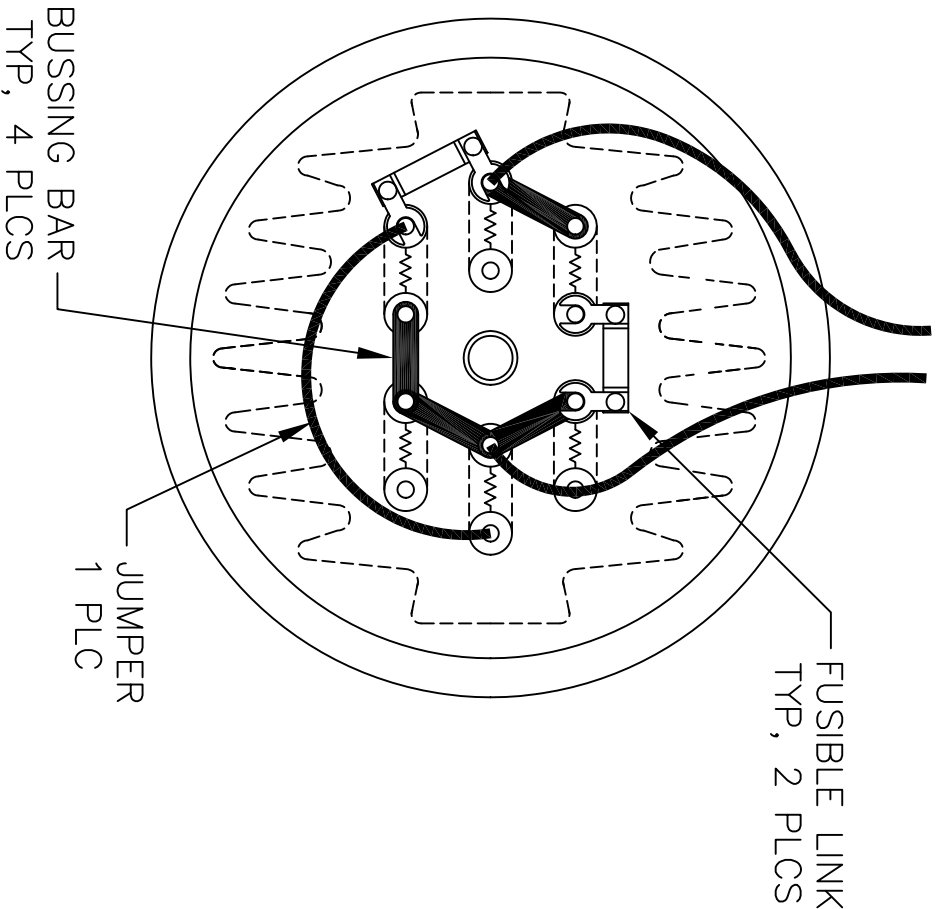

NOTE: CAPACITY FOLLOWED BY "AA" DENOTES AMMONIA CAPACITIES.

CAPACITY SIZE	VOLTAGE	HEATER	INDIVIDUAL HEATER OHMS	WIRE TO WIRE RESISTANCE
LPG	AA			
50	38AA	2595 WATTS @ 240VAC	22.2 OHMS	7.4 OHMS

1 CAPACITY SIZES SHOWN ARE IN KG/HR FOR LPG AND LB/HR FOR NH3

Algas-SOITM

151 S. Michigan St., Seattle, Washington, USA 98108
 Tel: (206) 789-5410 Fax: (206) 789-5414

Title

BUSSING DIAGRAM
 CAPACITY SIZE 50 & 38AA
 200V/208V/220V/240V 1PH
 TORREXX ELECTRIC VAPORIZER
 (REFERENCE 0620-7004A1C)

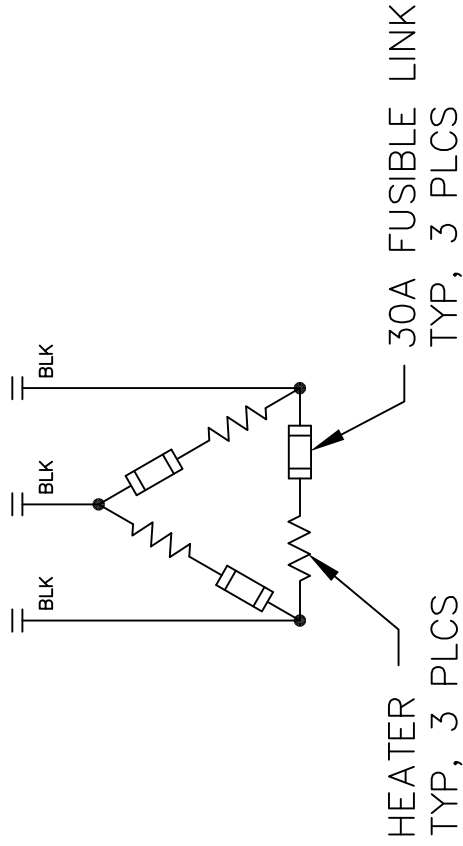
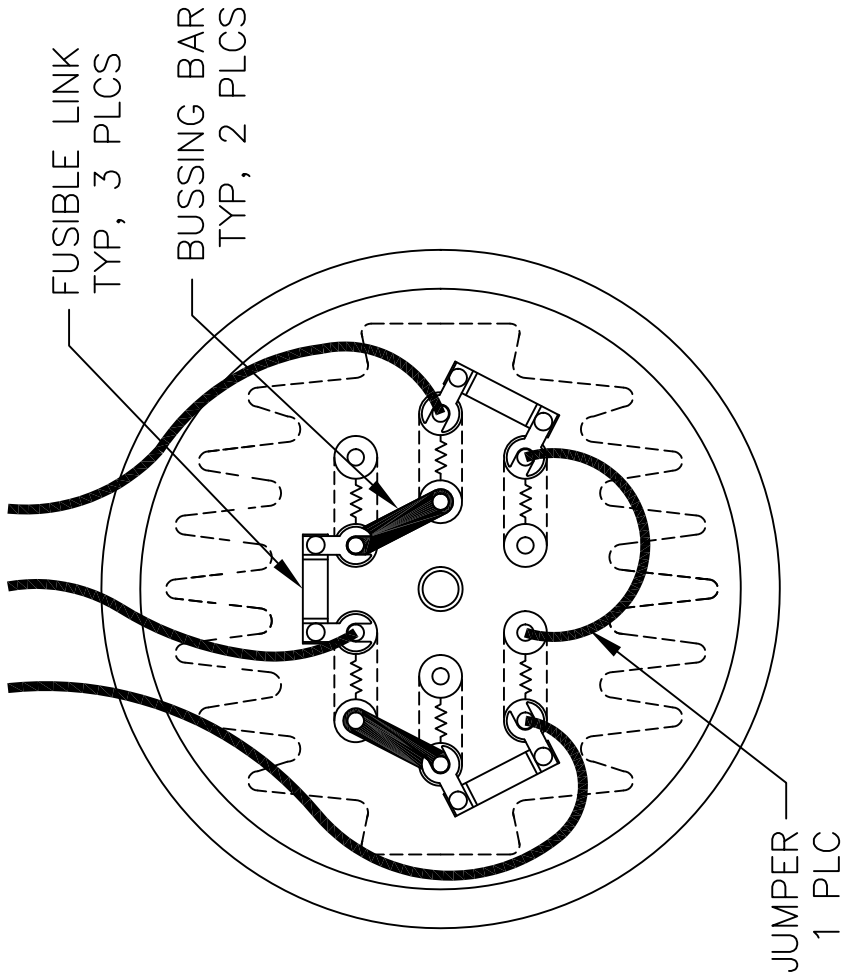

NOTE: CAPACITY FOLLOWED BY "AA" DENOTES AMMONIA CAPACITIES.

CAPACITY SIZE	VOLTAGE	HEATER	INDIVIDUAL HEATER OHMS	WIRE TO WIRE RESISTANCE
LPG				
50	200V/208V/220V/ 240V, 3PH	2595 WATTS @ 240VAC	22.2 OHMS	14.8 OHMS

△ CAPACITY SIZES SHOWN ARE IN KG/HR FOR LPG AND LB/HR FOR NH3 (AA)



151 S. Michigan St., Seattle, Washington, USA 98108
Tel: (206) 789-5410 Fax: (206) 789-5414

Title

BUSSING DIAGRAM
CAPACITY SIZE 50 & 38AA
200V/208V/220V/240V, 3 PH
TORREXX ELECTRIC VAPORIZER
(REFERENCE 0620-7005A1C)

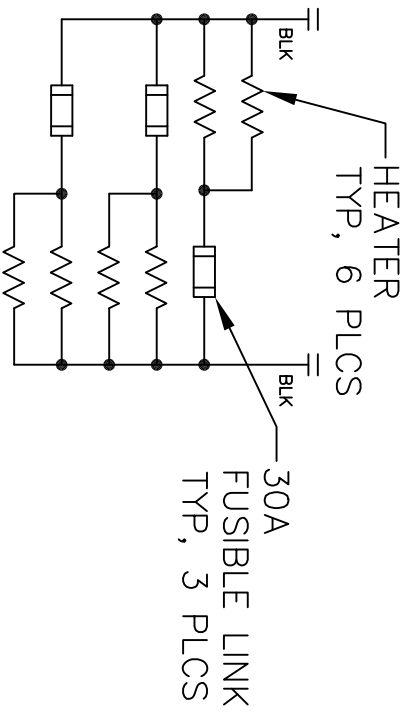
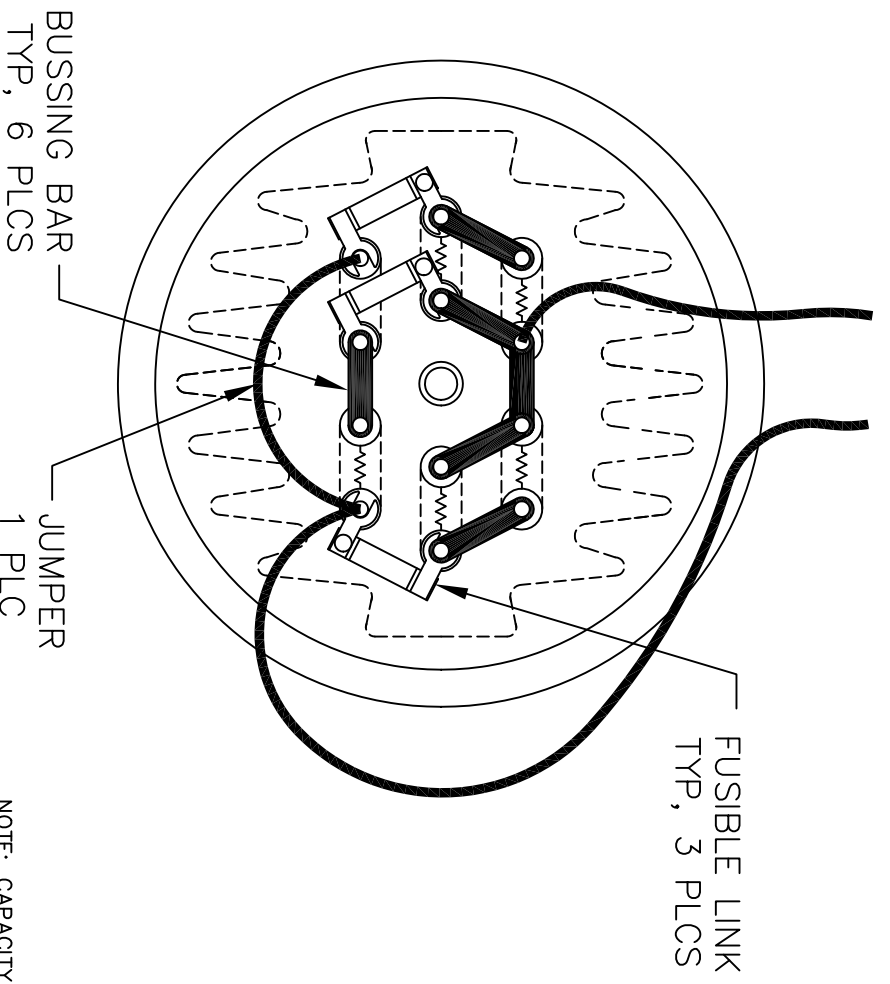

NOTE: CAPACITY FOLLOWED BY "AA" DENOTES AMMONIA CAPACITIES.

CAPACITY SIZE	VOLTAGE	HEATER	INDIVIDUAL HEATER OHMS	WIRE TO WIRE RESISTANCE
LPG	AA			
25	19AA	2595 WATTS @ 240VAC	22.2 OHMS	3.7 OHMS
100	75AA	2595 WATTS @ 240VAC	22.2 OHMS	3.7 OHMS

1 CAPACITY SIZES SHOWN ARE IN KG/HR FOR LPG AND LB/HR FOR NH3 (AA)



Algas-SOITM

151 S. Michigan St., Seattle, Washington, USA 98108
 Tel: (206) 789-5410 Fax: (206) 789-5414

Title

BUSSING DIAGRAM

CAPACITY SIZE 25, 19AA, 100, & 75AA
 110V/120V/200V/208V/220V, 1PH
 TORREXX ELECTRIC VAPORIZER
 (REFERENCE 0620-7007A1D)

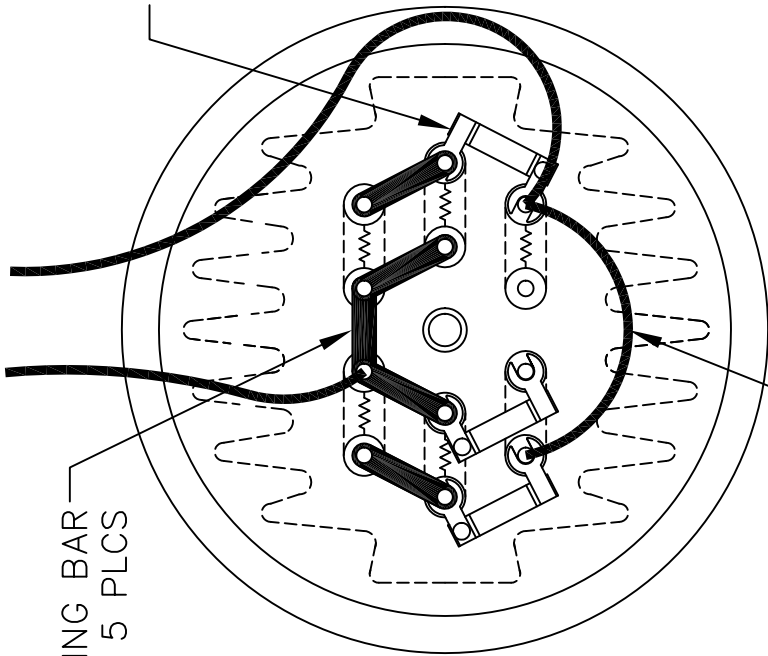

BUSSING BAR
TYP, 5 PLCS

HEATER
TYP, 5 PLCS

FUSIBLE LINK
TYP, 3 PLCS

30A
FUSIBLE LINK
TYP, 3 PLCS

JUMPER
1 PLC

NOTE: CAPACITY FOLLOWED BY "AA" DENOTES AMMONIA CAPACITIES.

CAPACITY SIZE	VOLTAGE	HEATER	INDIVIDUAL HEATER OHMS	WIRE TO WIRE RESISTANCE
LPG				
100	240V, 1PH	2595 WATTS @ 240VAC	22.2 OHMS	4.4 OHMS

△ CAPACITY SIZES SHOWN ARE IN KG/HR FOR LPG AND LB/HR FOR NH3 (AA)

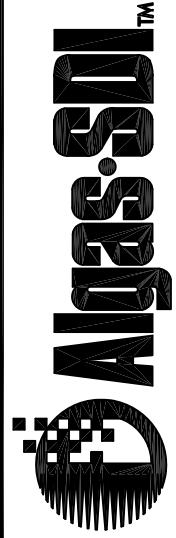

151 S. Michigan St., Seattle, Washington, USA 98108
Tel: (206) 789-5410 Fax: (206) 789-5414

Title

BUSSING DIAGRAM
CAPACITY SIZE 100 & 75AA
240V 1 PH
TORREXX ELECTRIC VAPORIZER
(REFERENCE 0620-7008A1C)

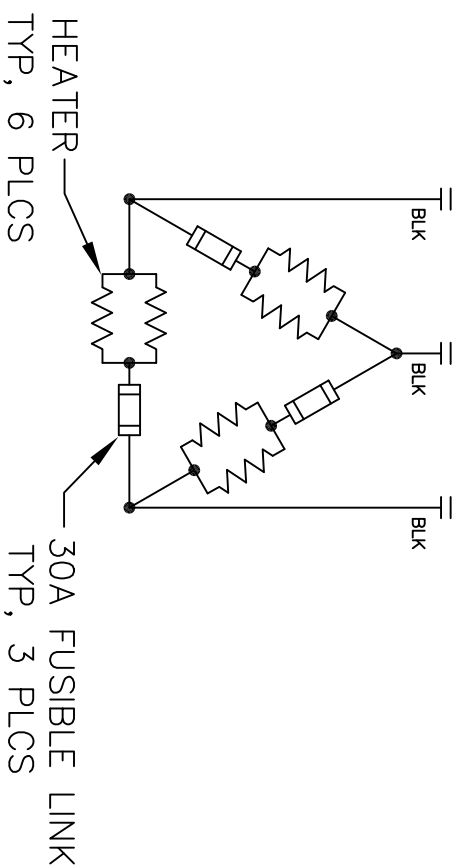
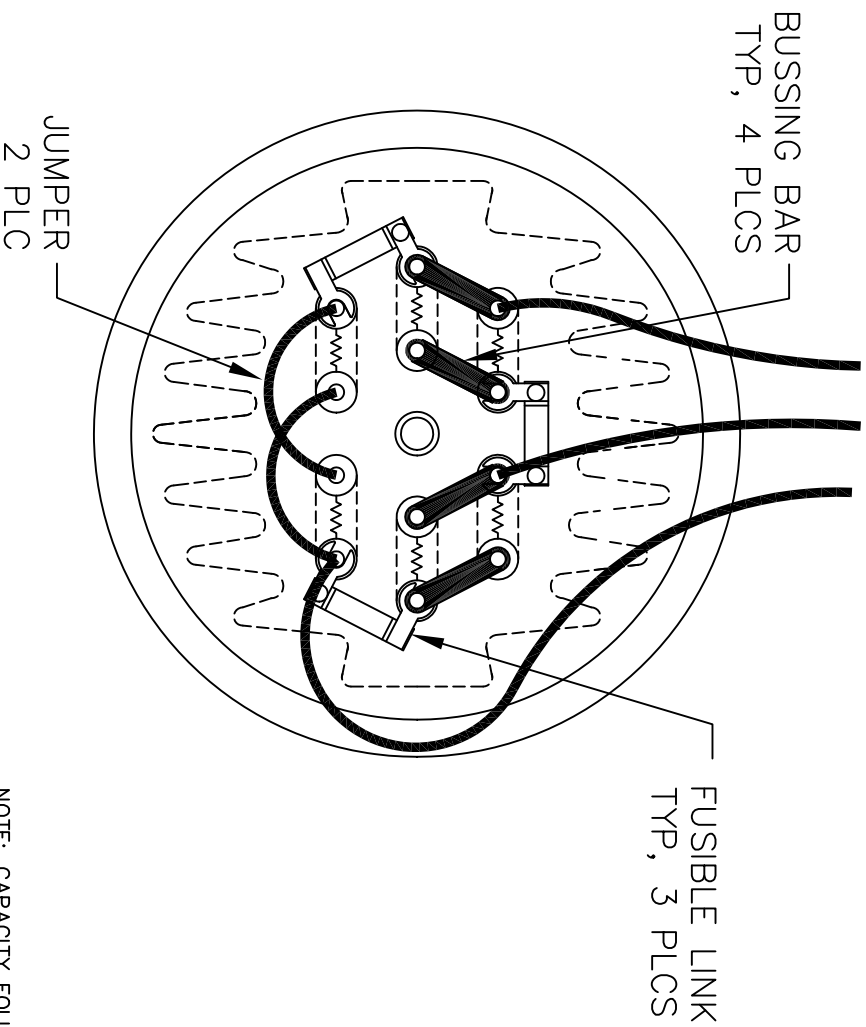

NOTE: CAPACITY FOLLOWED BY "AA" DENOTES AMMONIA CAPACITIES.

CAPACITY SIZE	VOLTAGE	HEATER	INDIVIDUAL HEATER OHMS	WIRE TO WIRE RESISTANCE
LPG	AA			
100	75AA	200V/208V/220V/ 240V, 3PH	2595 WATTS @ 240VAC	22.2 OHMS
160	120AA	200V/208V/220V/ 3PH	3333 WATTS @ 220VAC	14.5 OHMS
				7.4 OHMS
				4.8 OHMS

1 CAPACITY SIZES SHOWN ARE IN KG/HR FOR LPG AND LB/HR FOR NH3 (AA)

Algas-SOITM

151 S. Michigan St., Seattle, Washington, USA 98108
 Tel: (206) 789-5410 Fax: (206) 789-5414

Title

BUSSING DIAGRAM

CAPACITY SIZE 100, 75AA, 160, & 120AA
 200V/208V/220V/3PH & TX100/240V
 TORREXX ELECTRIC VAPORIZER
 (REFERENCE 0620-7009A1C)

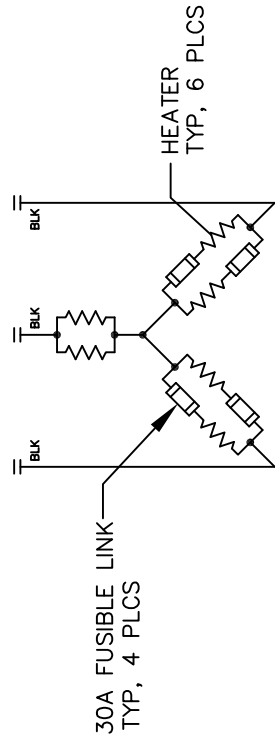
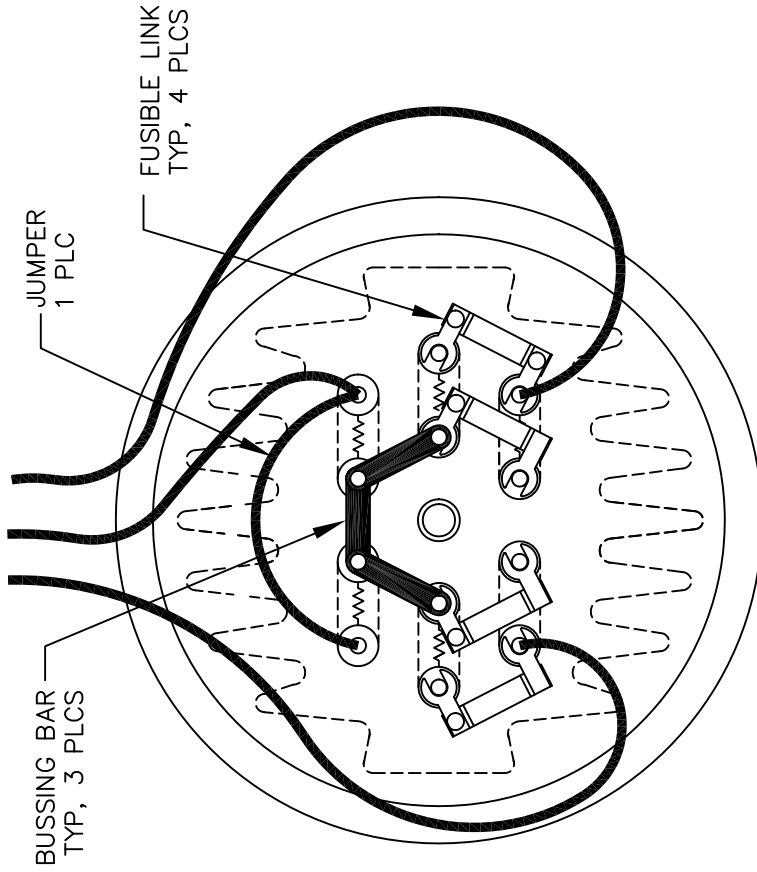

NOTE: CAPACITY FOLLOWED BY "AA" DENOTES AMMONIA CAPACITIES.

CAPACITY SIZE	VOLTAGE	HEATER	INDIVIDUAL HEATER OHMS	WIRE TO WIRE RESISTANCE
LPG	AA			
100	380V/415V, 3PH	2595 WATTS @ 240VAC	22.2 OHMS	22.2 OHMS
160	380V/415V, 3PH	3333 WATTS @ 220VAC	14.5 OHMS	14.5 OHMS
160	380V/400V/415V 3PH	3600 WATTS @ 240VAC	16.0 OHMS	16.0 OHMS
240	380V/415V, 3PH	5000 WATTS @ 220VAC	9.7 OHMS	9.7 OHMS
320	380V/400V/415V 3PH	6580 WATTS @ 240VAC	8.8 OHMS	8.8 OHMS
TX320 ONLY	380V/415V, 3PH	6580 WATTS @ 240VAC	8.8 OHMS	8.8 OHMS
100	575V 3PH	2595 WATTS @ 333VAC	42.7 OHMS	42.7 OHMS
160	575V 3PH	3333 WATTS @ 333VAC	33.3 OHMS	33.3 OHMS
240	575V 3PH	5000 WATTS @ 333VAC	22.2 OHMS	22.2 OHMS
320	575V 3PH	6580 WATTS @ 333VAC	16.9 OHMS	16.9 OHMS

△ CAPACITY SIZES SHOWN ARE IN KG/HR FOR LPG AND LB/HR FOR NH3 (AA)

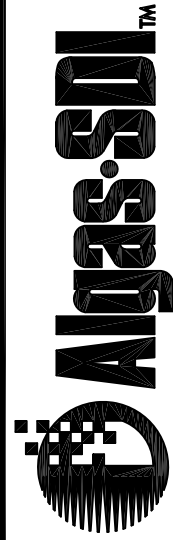

151 S. Michigan St., Seattle, Washington, USA 98108
 Tel: (206) 789-5410 Fax: (206) 789-5414

Title BUSSING DIAGRAM

CAPACITY SIZE

100 THRU 320 & 75AA THRU 240AA
 380V/415V/575V, 3 PH
 TORREXX ELECTRIC VAPORIZER
 (REFERENCE 0620-7010A1E)

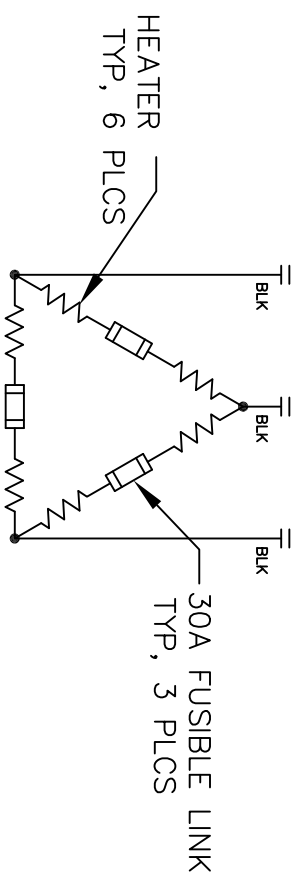
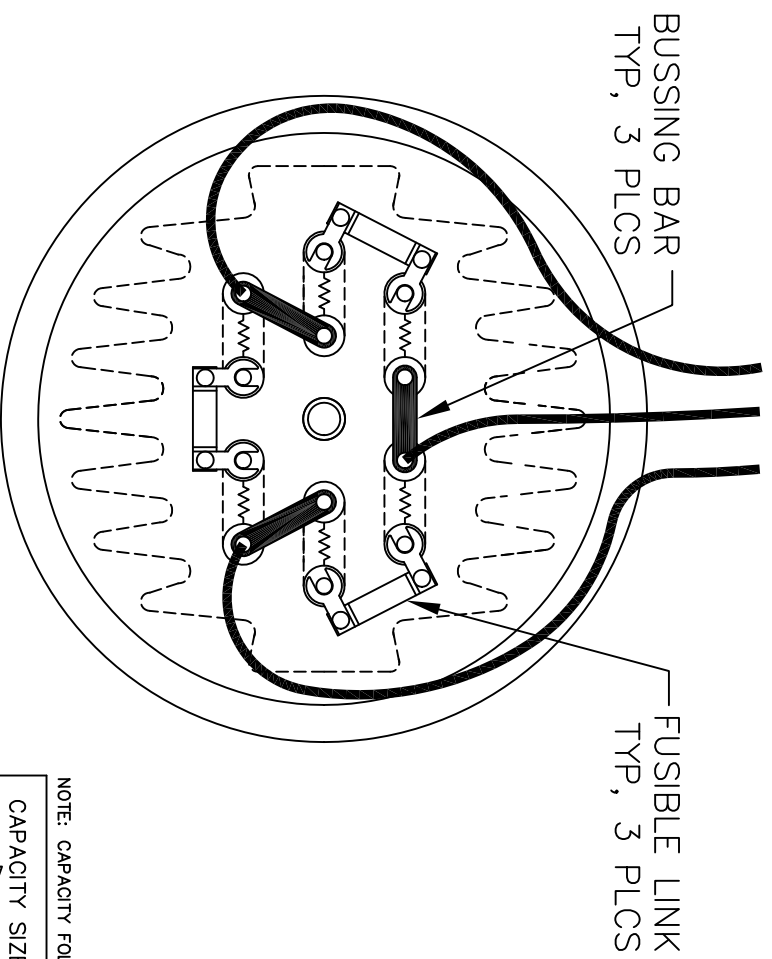

NOTE: CAPACITY FOLLOWED BY "AA" DENOTES AMMONIA CAPACITIES.

CAPACITY SIZE	VOLTAGE	HEATER	INDIVIDUAL HEATER OHMS	WIRE TO WIRE RESISTANCE
LPG				
AA				
80	120AAA	440V/480V, 3PH	3600 WATTS @ 240VAC	16.0 OHMS
100	75AAA	440V/480V, 3PH	2595 WATTS @ 240VAC	22.2 OHMS
160	120AAA	440V/480V, 3PH	3333 WATTS @ 220VAC	14.5 OHMS
240	180AAA	440V/480V, 3PH	5000 WATTS @ 220VAC	9.7 OHMS
320	240AAA	440V/480V, 3PH	6580 WATTS @ 240VAC	8.8 OHMS

1 CAPACITY SIZES SHOWN ARE IN KG/HR FOR LPG AND LB/HR FOR NH3 (AA)



151 S. Michigan St., Seattle, Washington, USA 98108
Tel: (206) 789-5410 Fax: (206) 789-5414

Title

BUSSING DIAGRAM

CAPACITY SIZE 80 THRU 320 &

75AA THRU 240AA

440V, 480V, 3 PH

TORREXX ELECTRIC VAPORIZER

(REFERENCE 0620-7011A1D)

BUSSING BAR

FUSIBLE LINK
TYP, 6 PLCS

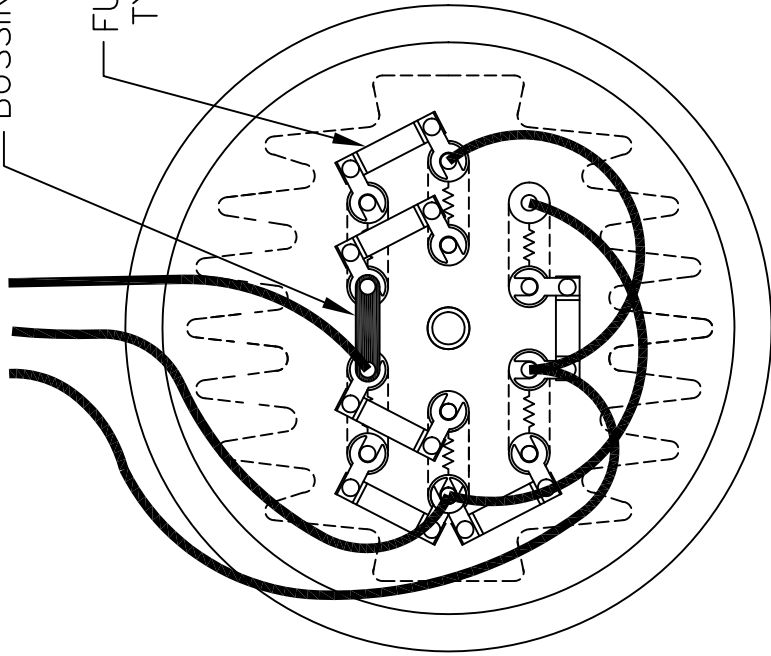

HEATER
TYP, 6 PLCS

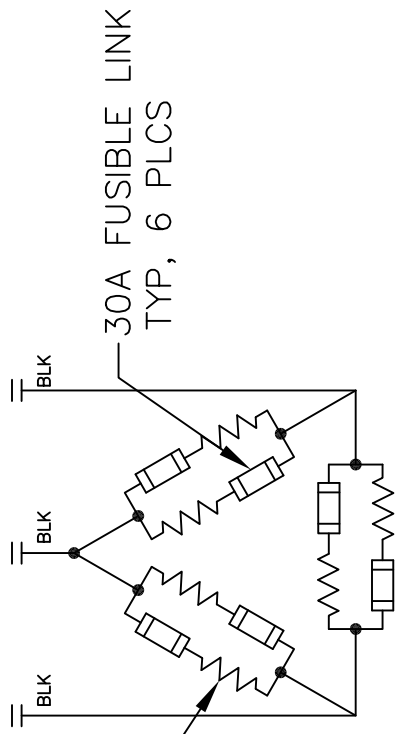

30A FUSIBLE LINK
TYP, 6 PLCS

NOTE: CAPACITY FOLLOWED BY "AA" DENOTES AMMONIA CAPACITIES.

CAPACITY SIZE 1	VOLTAGE	HEATER	INDIVIDUAL HEATER OHMS	WIRE TO WIRE RESISTANCE
LPG AA				
160 120AA	240V, 3PH	3333 WATTS @ 220VAC	14.5 OHMS	4.8 OHMS
160 120AA	208V/220V/240V 3PH	3600 WATTS @ 240VAC	16.0 OHMS	5.3 OHMS
240 180AA	200V/208V/ 220V/240V, 3PH	5000 WATTS @ 220VAC	9.7 OHMS	3.2 OHMS

1 CAPACITY SIZES SHOWN ARE IN KG/HR FOR LPG AND LB/HR FOR NH3 (AA)



151 S. Michigan St., Seattle, Washington, USA 98108
Tel: (206) 789-5410 Fax: (206) 789-5414

Title

BUSSING DIAGRAM

CAPACITY SIZE 160, 120AA, 240 & 180AA
200V/208V/220V/240V, 3PH
TORREXX ELECTRIC VAPORIZER
(REFERENCE 0620-7012A1E)

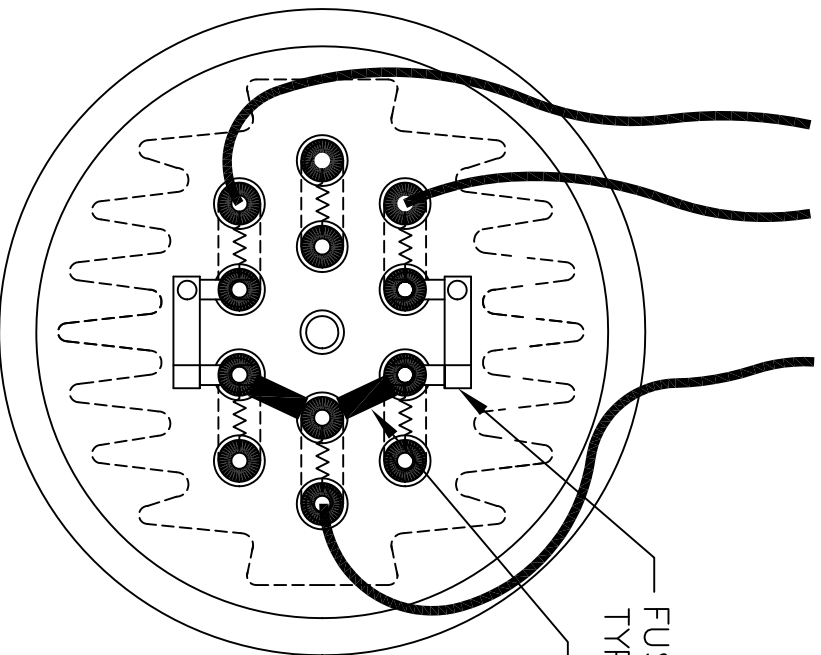

FUSIBLE LINK
TYP, 2 PLCS

BUSSING STRIP
TYP 2 PLCS

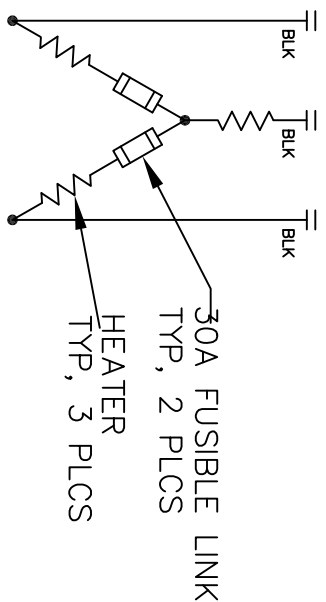

NOTE: CAPACITY FOLLOWED BY "AA" DENOTES AMMONIA CAPACITIES.

CAPACITY SIZE	VOLTAGE	HEATER	INDIVIDUAL HEATER OHMS	WIRE TO WIRE RESISTANCE
LPG	AA			
25	31AA	2595 WATTS @ 240VAC	22.2 OHMS	44.4 OHMS
*60	75AA	5000 WATTS @ 220VAC	9.68 OHMS	4.84 OHMS
**80	100AA	6580 WATTS @ 220VAC	7.36 OHMS	3.68 OHMS
**80	100AA	6580 WATTS @ 240VAC	8.75 OHMS	4.38 OHMS

* USES 120 SIZE CORE

**USES 160 SIZE CORE

△ CAPACITY SIZES SHOWN ARE FOR LPG EX, XP, P, XPV, & XPM SERIES POWER VERTICAL VAPORIZERS

Algas-SOITM

151 S. Michigan St., Seattle, Washington, USA 98108
Tel: (206) 789-5410 Fax: (206) 789-5414

Title BUSSING DIAGRAM

CAPACITY SIZE 50, 38AA, 120, 75AA
160 & 120AA
380V/415V 3PH

TORREXX ELECTRIC VAPORIZER
(REFERENCE 0620-7028A1B)

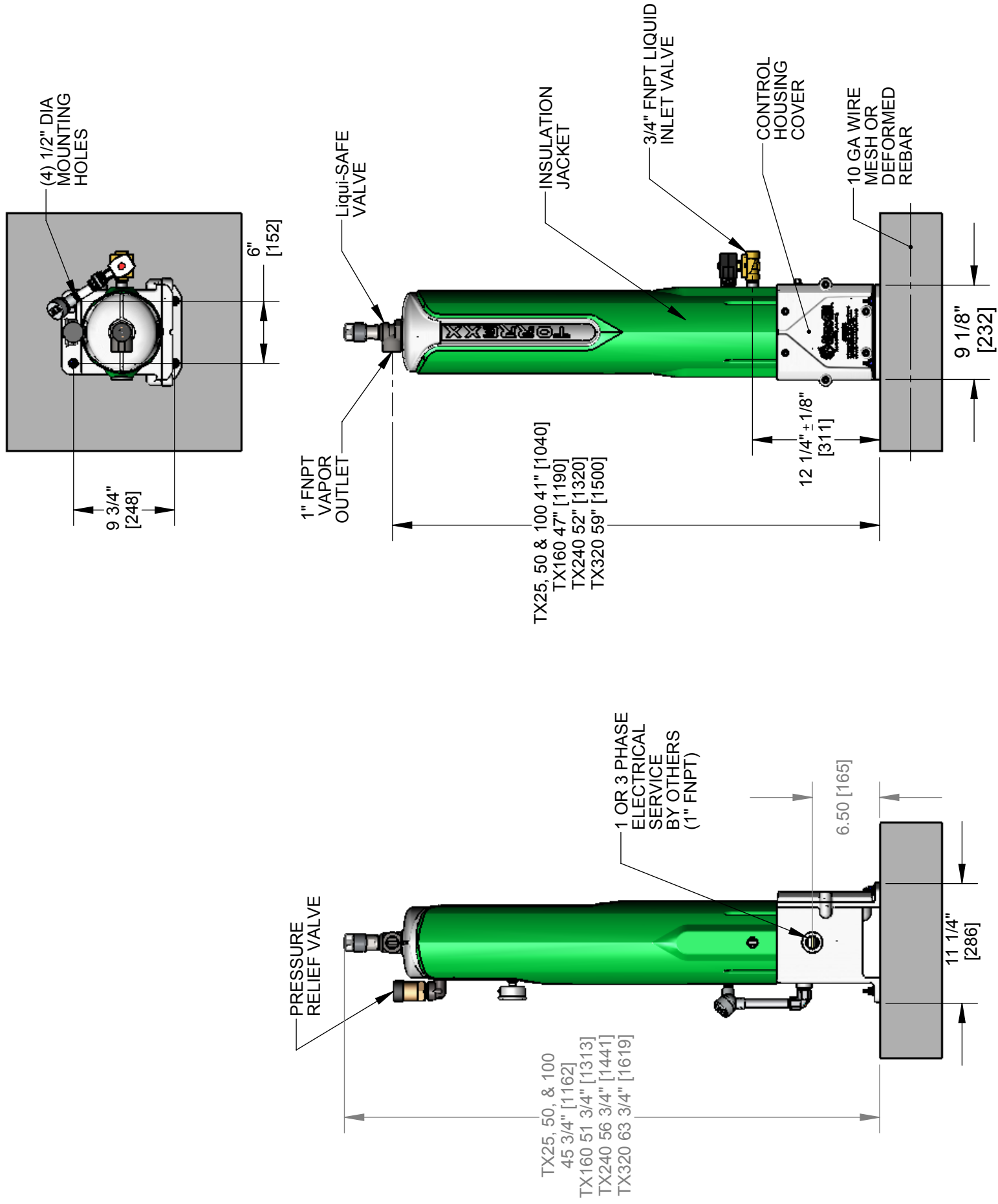

- NOTES:
- ALL DIMENSIONS ARE IN INCHES [mm].
 - FM AND FMC APPROVED. FOR USE IN CLASS 1 DIVISION 1 GROUP D AREAS.
 - EXPLOSION PROOF CONTROL BOX MEETS NEMA 4 REQUIREMENTS.
 - VAPORIZER PRESSURE VESSEL RATED AT 250 PSIG [17.6 KG/CM²] MAWP.
 - VAPORIZER RELIEF VALVE SETTING 250 PSIG [17.6 KG/CM²].
 - VAPORIZER CAPACITY RATED AT 0° F AND 100 PSIG PROPANE INLET CONDITION.
 - SUITABLE FOR INDOOR/OUTDOOR INSTALLATION.
 - VAPORIZER TO BE SECURED THROUGH THE FOUR MOUNTING HOLES ON ABOVE GROUND, LEVEL, SOLID, NON-COMBUSTIBLE BASE.
 - AVOID DRY RUBBING OF THE INSULATION JACKET TO PREVENT ELECTROSTATIC CHARGING HAZARD. ALWAYS USE DAMP CLOTH FOR CLEANING.
 - ECONOMY VALVE OPTION AVAILABLE UPON REQUEST.
 - APPROXIMATE SHIPPING WEIGHT: TX25-100 (128lbs.) TX160 (145lbs.) TX240 (155lbs.) TX320 (173lbs.)

THIRD ANGLE PROJECTION 	TOLERANCES UNLESS OTHERWISE SPECIFIED .X ± .XX ± .XXX ± ANGLE ±0°30' FRACTIONS ± 1/4"	Algas.SDI 151 S. Michigan St., Seattle, Washington, USA 98108 Tel: (206) 789-5410 Fax: (206) 789-5414	Drawn By: RWP
			Checked By: DN
DO NOT SCALE DRAWING <small>INTERPRET THIS DRAWING IN ACCORDANCE WITH ANSI/ASME Y14.5-2009</small>	Part #	Job #	Approved By:
<small>THIS DRAWING SHALL NOT BE REPRODUCED OR USED IN ANY MANNER DETRIMENTAL TO ITS INTERESTS. ALL RIGHTS RESERVED. © COPYRIGHT ALGAS.SDI</small>	Title:	Date: 10/20/06	Scale: 1:12 AND NOTED
TORREXX SERIES ELECTRIC VAPORIZER - STANDARD			Job # A.S.D.I. STD.
Size: B	Dwg. # 5001-6001	Sht. No.: 1 of 1	Rev.: D

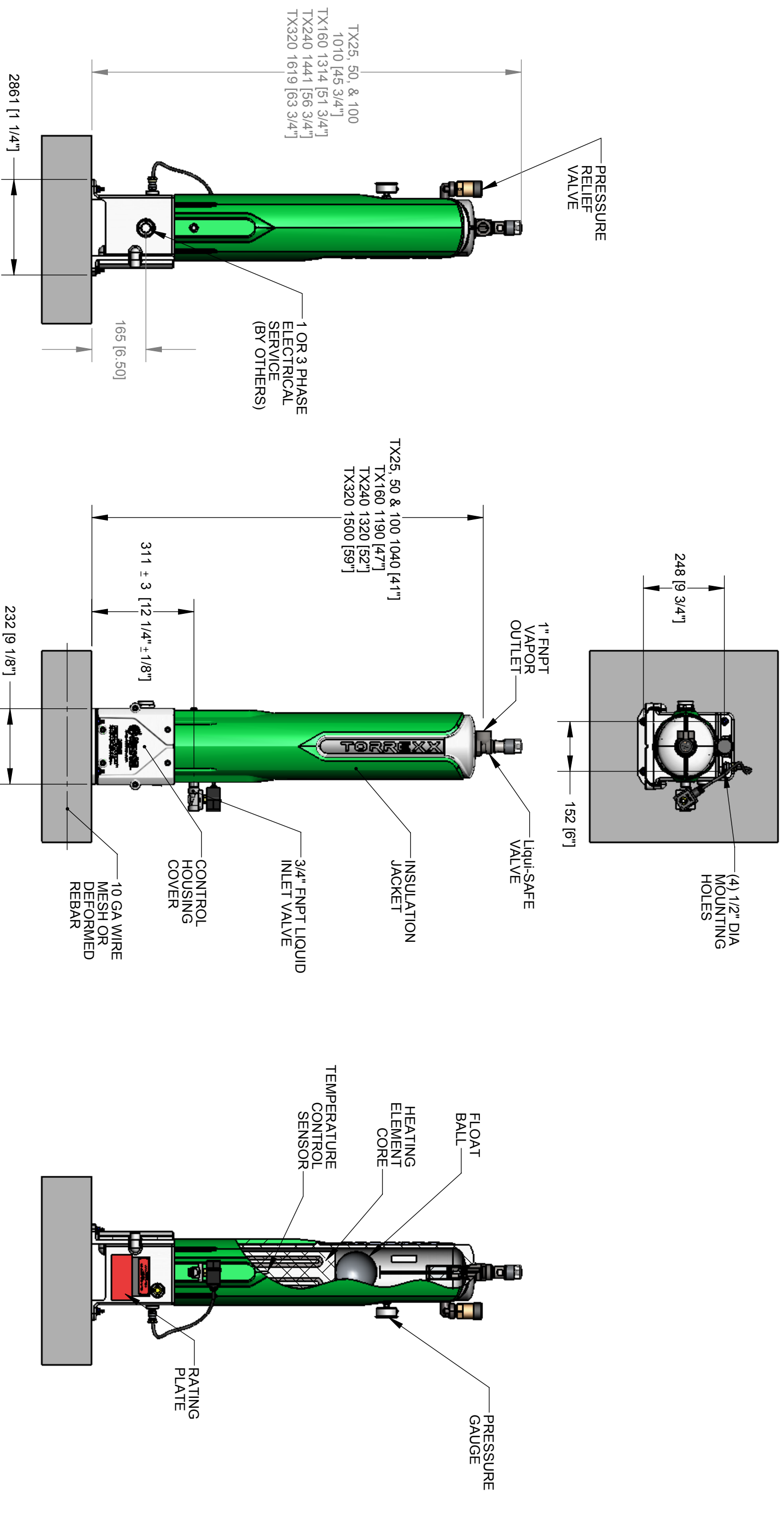

- NOTES:
1. ALL DIMENSIONS ARE IN mm (INCHES).
 2. CONFORMS TO HAZARDOUS AREA RATING: EEx d II B T3/ Ex II 2G-DNV 06 ATEX Q166Q.
 3. PRESSURE VESSEL CONFORMS TO PRESSURE EQUIPMENT DIRECTIVE: 40065-2011-CE-USA-DNV REV 1.
 4. CE COMPLIANT.
 5. VAPORIZER PRESSURE VESSEL RATED AT 250 PSIG [17.6 KG/CM² MAWP.
 6. RELIEF VALVE SETTING 17.24 BARG (250PSIG).
 7. VAPORIZER CAPACITY RATED 0 ° F AND 100 PSIG PROPANE INLET CONDITION.
 8. SUITABLE FOR INDOOR/OUTDOOR INSTALLATION.
 9. VAPORIZER TO BE SECURED THROUGH THE FOUR MOUNTING HOLES ON ABOVE GROUND, LEVEL, SOLID, NON-COMBUSTIBLE BASE.
 10. AVOID DRY RUBBING OF THE INSULATION JACKET TO PREVENT ELECTROSTATIC CHARGING HAZARD. ALWAYS USE DAMP CLOTH FOR CLEANING.
 11. ECONOMY VALVE OPTION AVAILABLE UPON REQUEST.
 12. APPROXIMATE SHIPPING WEIGHT: TX25-100 (58kg) TX160 (66kg) TX240 (70kg) TX320 (79kg).

THIRD ANGLE PROJECTION	TOLERANCES UNLESS OTHERWISE SPECIFIED	DO NOT SCALE DRAWING	ANGLE ± 0 ° 30'	FRACTIONS ± 1/16"	THIS DRAWING IS IN ACCORDANCE WITH ANSI/ASME Y14.5-2009	THIS DRAWING SHALL NOT BE REPRODUCED OR USED IN ANY MANNER WITHOUT THE WRITTEN INTERESTS ALL RIGHTS RESERVED. © COPYRIGHT ALGAS.SDI
	.X ± .XX ± .XXX ±		.X ± .XX ± .XXX ±	.X ± .XX ± .XXX ±	INTERPRET THIS DRAWING IN ACCORDANCE WITH ANSI/ASME Y14.5-2009	© COPYRIGHT ALGAS.SDI
		TORREXX SERIES ELECTRIC VAPORIZER - NEMKO		Title:		Size: B
151 S. Michigan St., Seattle, Washington, USA 98108 Tel: (206) 787-5410 Fax: (206) 787-5414		Part #		Dwg. #		5001-6003
Drawn By: RWP		Checked By: DN		Date: 10/23/06		Sht. No.: 1 of 1
Approved By:		Scale: 1:12 AND NOTED		Job # A.S.D.I. STD.		Rev.: D

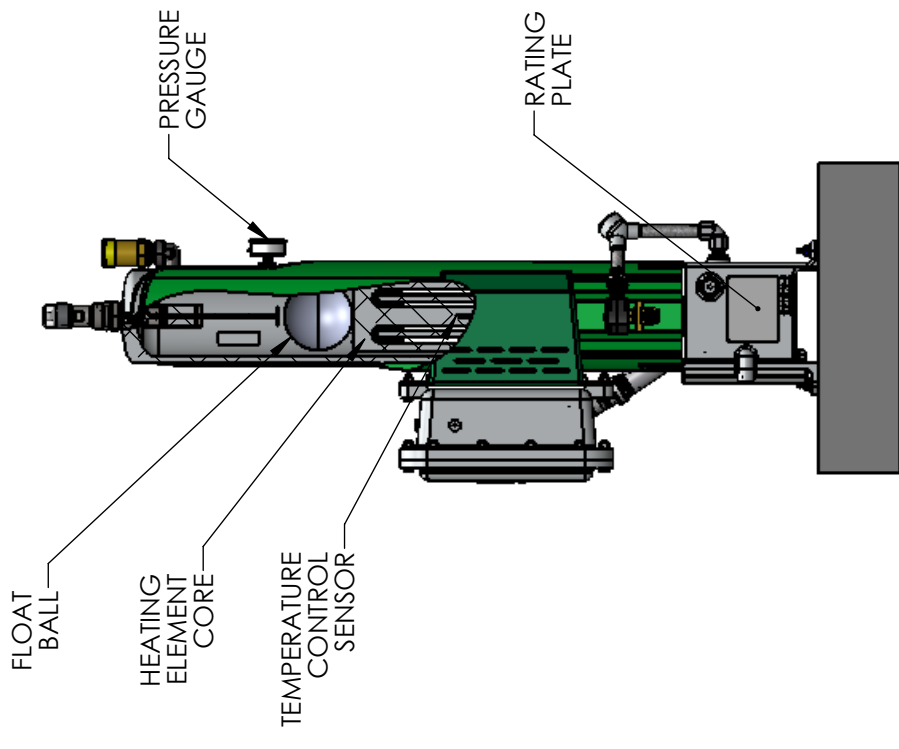
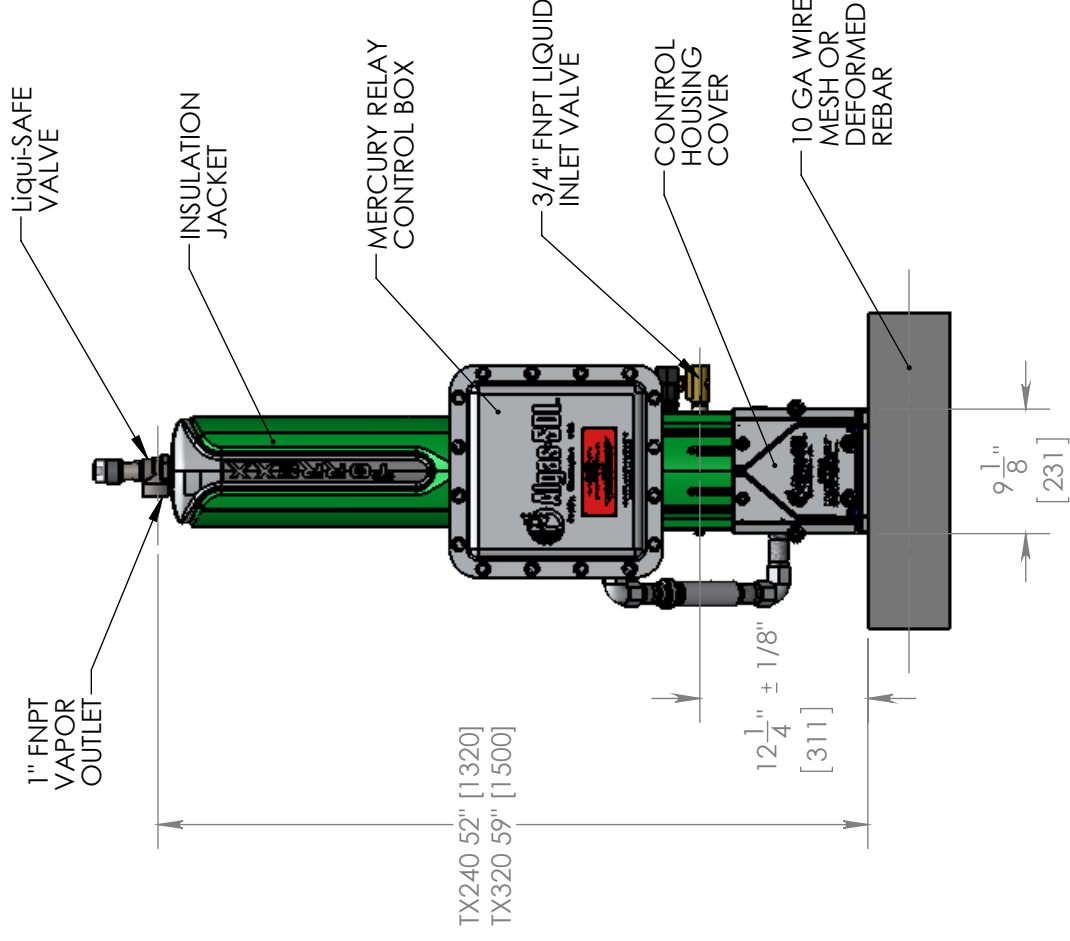
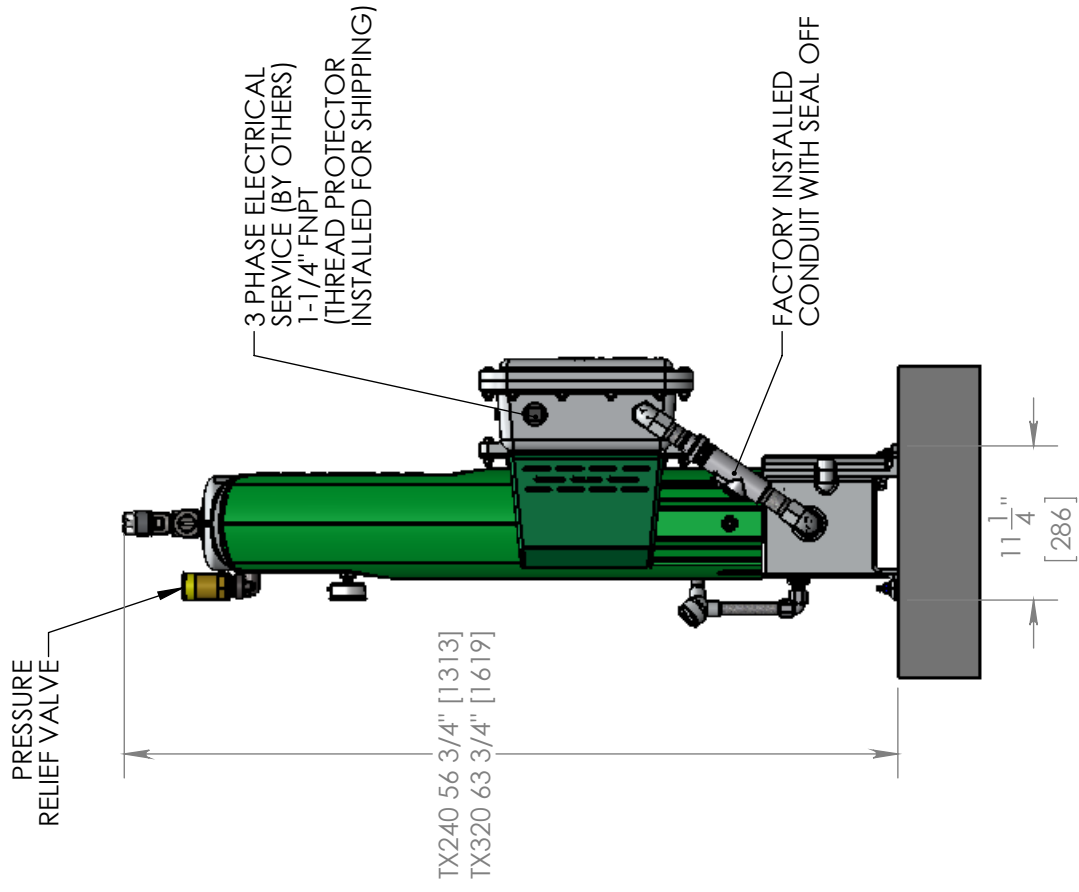
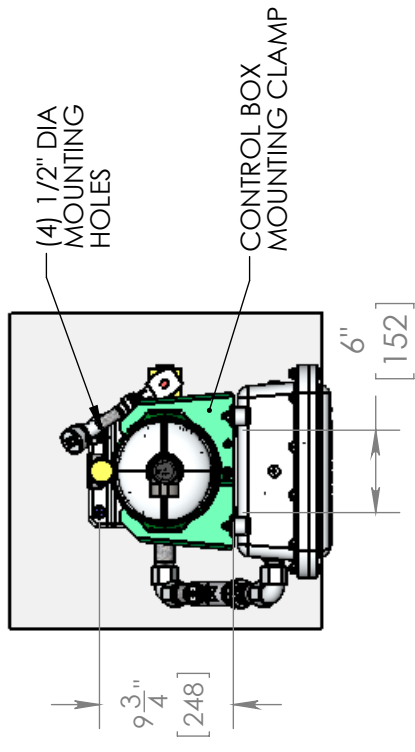

NOTES:

- ALL DIMENSIONS ARE IN INCHES [mm].
- FM AND FMC APPROVED FOR USE IN CLASS 1 DIVISION 1 GROUP D AREAS.
- EXPLOSION PROOF CONTROL BOX MEETS NEMA 4 REQUIREMENTS.
- VAPORIZER PRESSURE VESSEL RATED AT 250 PSIG [17.6 KG/CM²] MAWP.
- VAPORIZER RELIEF VALVE SETTING 250 PSIG [17.6 KG/CM²].
- VAPORIZER CAPACITY RATED AT 0° F AND 100 PSIG PROPANE INLET CONDITION.
- SUITABLE FOR INDOOR/OUTDOOR INSTALLATION.
- VAPORIZER TO BE SECURED THROUGH THE FOUR MOUNTING HOLES ON ABOVE GROUND, LEVEL, SOLID, NON-COMBUSTIBLE BASE.
- AVOID DRY RUBBING OF THE INSULATION JACKET TO PREVENT ELECTROSTATIC CHARGING HAZARD. ALWAYS USE DAMP CLOTH FOR CLEANING.
- ECONOMY VALVE OPTION AVAILABLE UPON REQUEST.
- APPROXIMATE SHIPPING WEIGHT: TX240 (205lbs.) TX320 (223lbs.)

THIRD ANGLE PROJECTION



DO NOT SCALE DRAWING

INTERPRET THIS DRAWING IN ACCORDANCE WITH ANSI/ASME Y14.5-2009

THIS DRAWING SHALL NOT BE REPRODUCED OR USED IN ANY MANNER DETRIMENTAL TO ITS INTERESTS. ALL RIGHTS RESERVED.
© COPYRIGHT ALGAS.SDI

TOLERANCES

UNLESS OTHERWISE SPECIFIED

.X ±
.XX ±
.XXX ±

ANGLE +0° 30'

FRACTIONS ± 1/4"



151 S. Michigan St., Seattle, Washington, USA 98108
Tel: (206) 789-5410 Fax: (206) 789-5414

Part #

Date: 5/14/12

Scale: 1:1 AND NOTED

Job # A.S.D.I. STD.

Drawn By: RWP

Checked By: DN

Approved By:

Date: 5/14/12

Scale: 1:1 AND NOTED

Job # A.S.D.I. STD.

TORREXX SERIES ELECTRICAL VAPORIZER-MERCURY RELAY

Size: **B**

Dwg. #

5001-6005

Sht. No.: 1 of 1

Rev.: **A**

REVISIONS		REV. BY
REV	DESCRIPTION	
B	ADDED THERMOCOUPLE CONNECTOR, NOTE #4.	K.B. 06-08-09

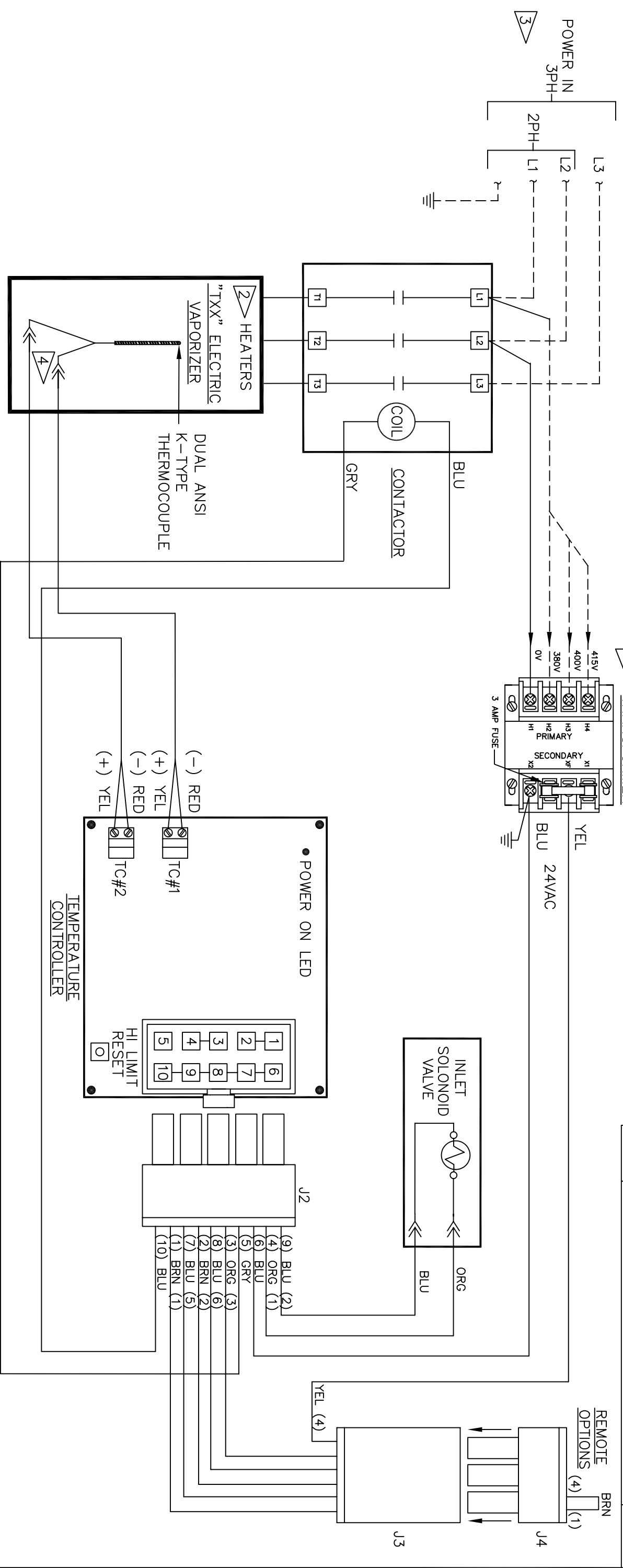

▷ 120 THRU 575 VOLT CONFIGURATION

A.S.D.I. P/N	A.S.D.I. P/N	A.S.D.I. P/N	A.S.D.I. P/N	A.S.D.I. P/N	PRIMARY
52605-01	52606-01	52607-01	52608-01		H4
240V	240V	415V	575V		H3
220V	220V	400V	480V		H2
120V	208V	380V	440V		H1
COMMON/OV	COMMON/OV	COMMON/OV	COMMON/OV		

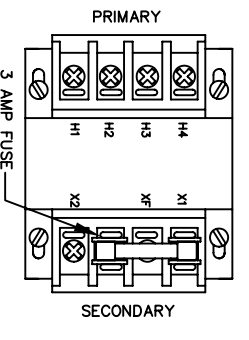

- NOTES
- 1 SEE TRANSFORMER CONFIGURATIONS FOR OTHER VOLTAGE CONFIGURATIONS.
 - 2 REFER TO MANUAL FOR BUSSING DIAGRAM REFER TO RATING PLATE FOR MODEL AND VOLTAGE.
 - 3 "L1 AND L2" USED ON SINGLE PHASE MODELS
 - 4 "L1, L2 AND L3" USED ON 3 PHASE MODELS FOR "H" CONFIGURATION, USE THERMOCOUPLE CONNECTORS WITH SHIELDED EXTENSION WIRE. GROUND SHIELD WIRES IN CONTROL BOX.

LEGEND

----- FIELD WIRING

◀◀ WIRE CONNECTOR SYMBOL

151 S. Michigan St., Seattle, Washington, USA 98108
Tel: (206) 789-5410 Fax: (206) 789-5414

Title
"TORREXX" ELECTRIC VAPORIZER
WIRING SCHEMATIC

Drawn By G. ROPPE	Date 3-1-06	Dwg. No. 5001-7008
Checked By	Scale NONE	
Approved By	Job No. A.S.D.I. STD.	

This drawing is the property of Algas-SDI and is not to be reproduced nor used in any manner detrimental to our interests. All rights are reserved.

Part Number	Size B	Sht. No. 1 of 1	Rev B
-------------	------------------	--------------------	----------

J4 - TORREXX REMOTE WIRE ASSEMBLY 3 FT A.S.D.I. P/N 53822

JUNCTION BOX (CLASS 1 DIVISION 1) BY OTHERS

FIELD WIRING MAXIMUM DISTANCE FROM VAPORIZER:
 150 FT. W/16 GA WIRE,
 250 FT. W/14 GA WIRE,
 475 FT. W/12 GA WIRE

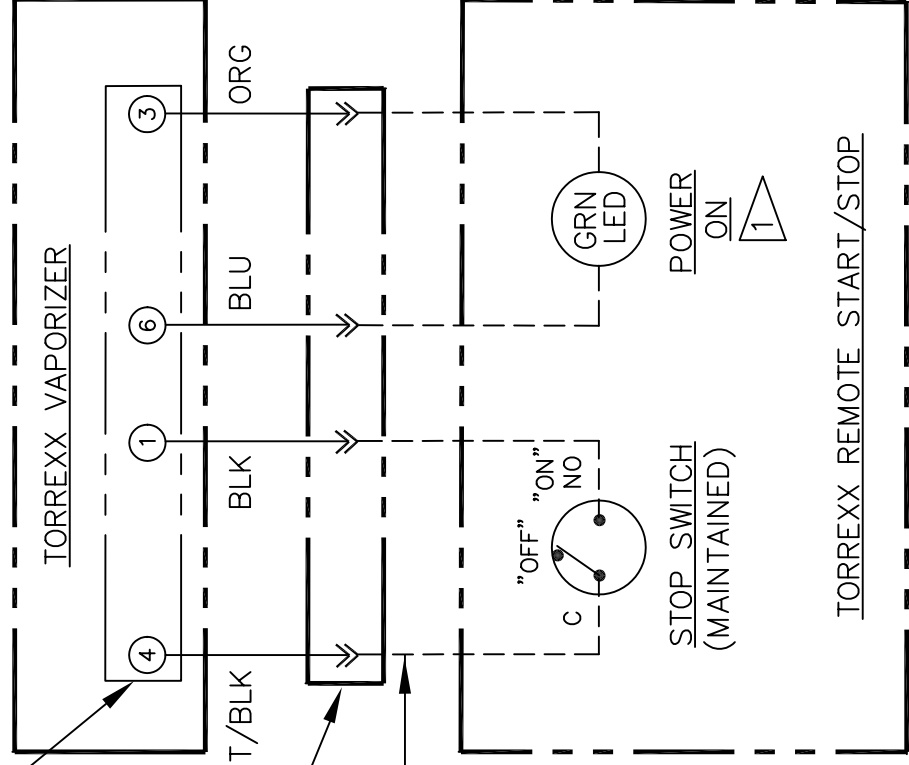

1. 'POWER ON' LAMP WILL TURN ON AFTER 30-60 SECONDS AFTER THE START SWITCH IS PUSHED. HOWEVER IF THE VAPORIZER IS ALREADY WARM, THE LAMP WILL TURN ON IMMEDIATELY AFTER THE START SWITCH IS PUSHED.
2. FOR INDOOR/OUTDOOR INSTALLATION IN A GENERAL PURPOSE LOCATION ONLY.
3. ENCLOSURE RATING: IP65
4. ENCLOSURE MATERIAL: ABS THERMOPLASTIC
- » CONNECTOR OR TERMINAL BLOCK

REVISIONS	
REV	DESCRIPTION
A	INITIAL RELEASE
B	CHANGED INDICATOR TO 'POWER ON' & 'START/STOP'

REV. BY
K.B.
07-24-09

SRB
11/09/09

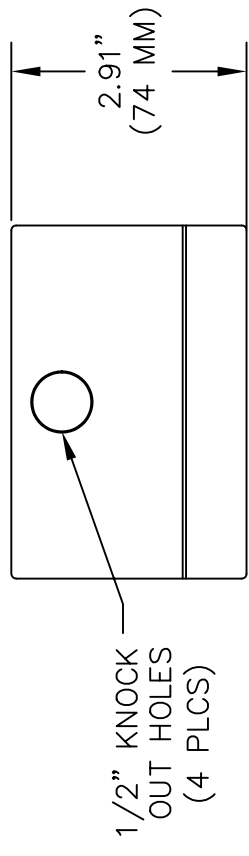

TOP VIEW

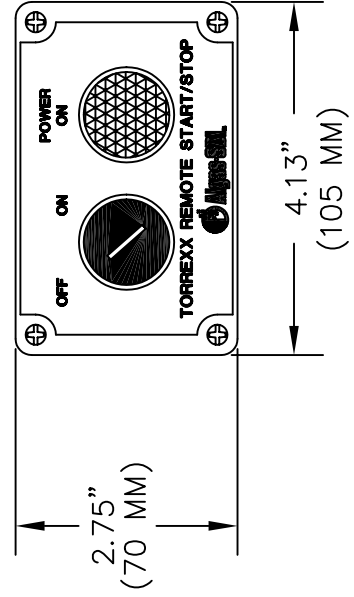

FRONT VIEW

8-32 X 1/2" OR
 8-32 X 3/4" LG
 W/8-32 NYLOKNUT

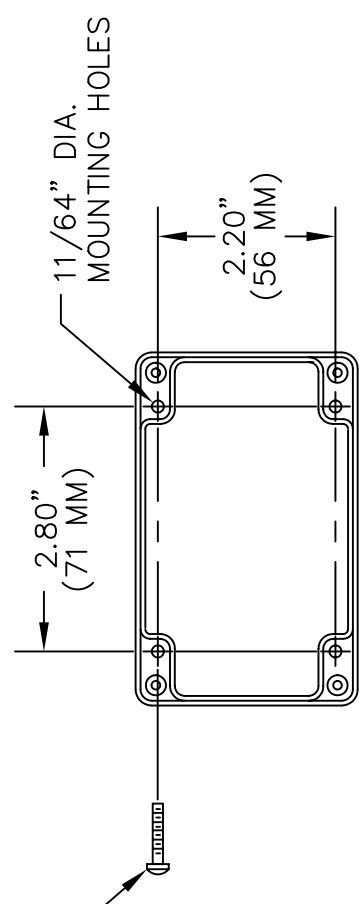

MOUNTING HOLE LOCATION

<p>151 S. Michigan St., Seattle, Washington, USA 98108 Tel: (206) 789-5410 Fax: (206) 789-5414</p>	Title "TORREXX" ELECTRIC VAPORIZER REMOTE BOX SCHEMATIC & INSTALLATION INSTRUCTIONS	
	Dwg. No. 5001-7009	Date 7-24-09
Drawn By K. BROWN	Scale NONE	Job No. A.S.D.I. STD.
Checked By DN	Part Number 41067	Size B
Approved By		Sht. No. 1 of 1
This drawing is the property of Algas SDI and is not to be reproduced nor used in any manner detrimental to our interests. All rights are reserved.		

Rev
B

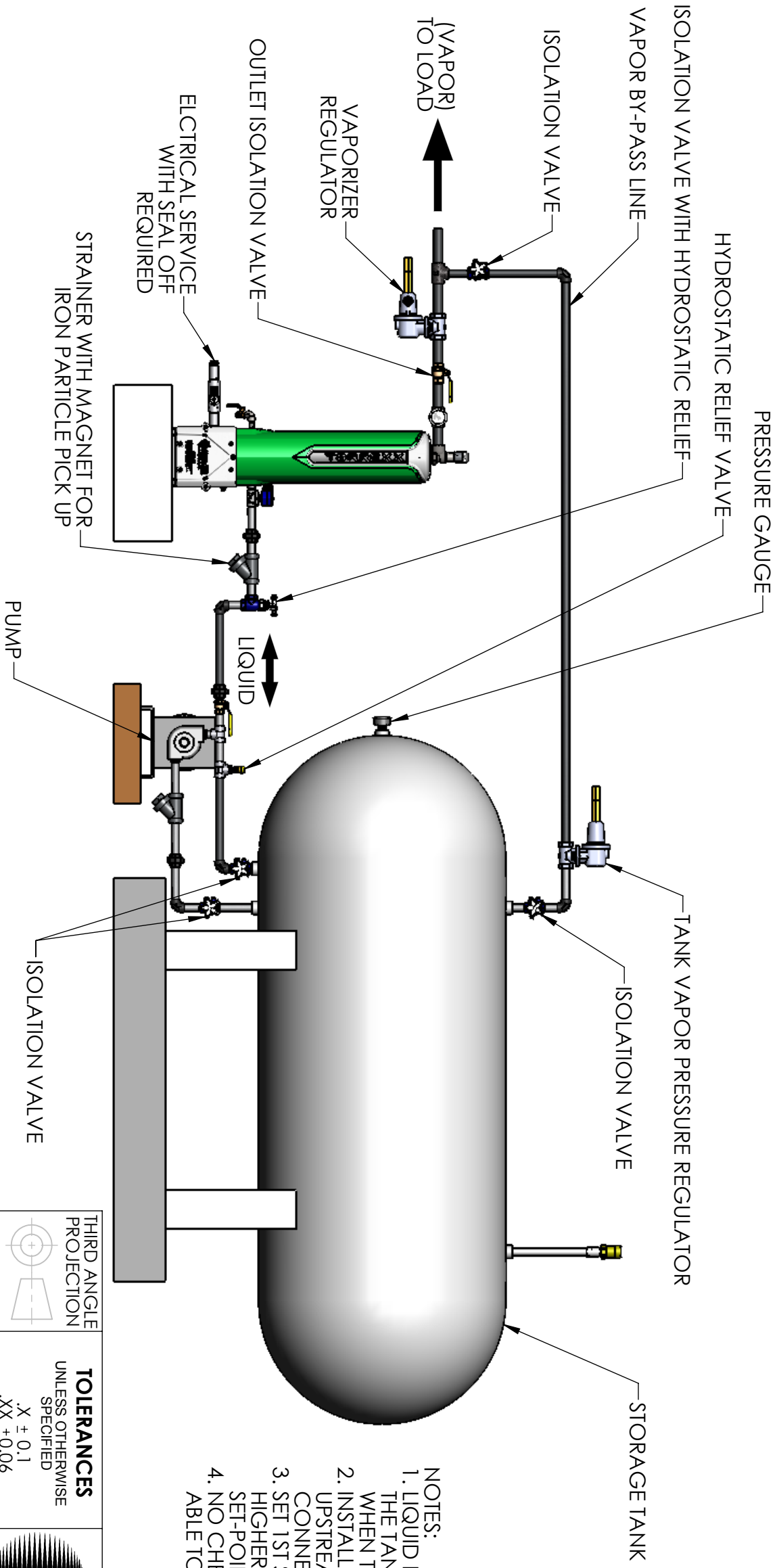
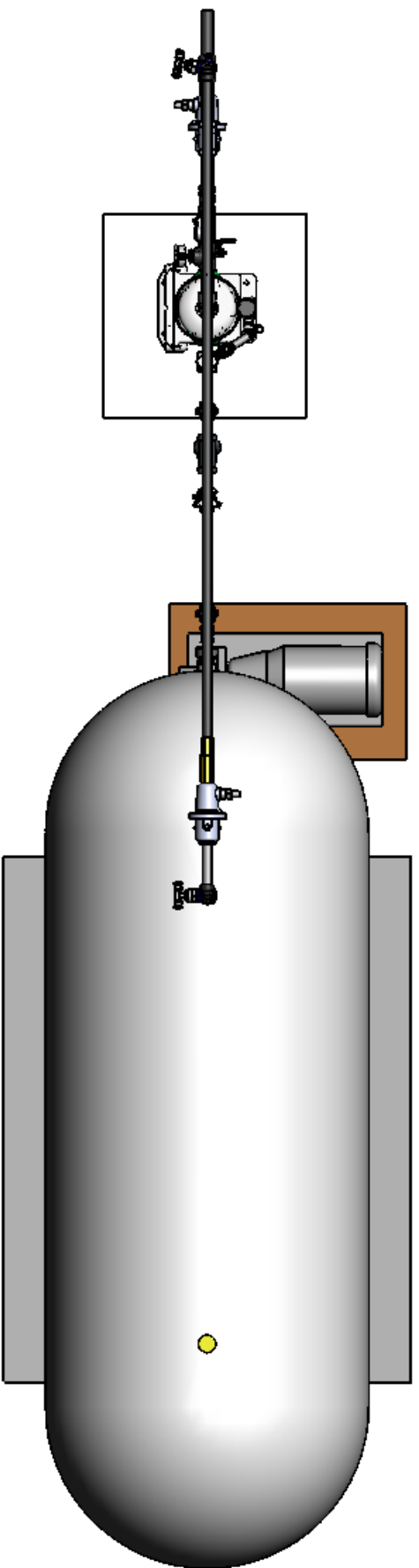

- NOTES:
1. LIQUID PIPING LOSSES BETWEEN VAPORIZER AND THE TANK MUST NOT EXCEED HYDROSTATIC HEAD WHEN THE PUMP IS SHUT OFF.
 2. INSTALL VAPORIZER 1ST STAGE REGULATOR UPSTREAM OF THE TANK VAPOR PRESSURE CONNECTION POINT.
 3. SET 1ST STAGE VAPORIZER REGULATOR 2-4 PSIG HIGHER THAN TANK VAPOR PRESSURE REGULATOR SET-POINT.
 4. NO CHECK VALVES IN LIQUID LINE. LIQUID MUST BE ABLE TO FLOW IN BOTH DIRECTIONS.

THIRD ANGLE PROJECTION	TOLERANCES UNLESS OTHERWISE SPECIFIED	Drawn By: A. EGILOLI
DO NOT SCALE DRAWING	<p>X ± 0.1</p> <p>XX ± 0.06</p> <p>.XXX ± 0.030</p>	Checked By: DN
ANGLE ± 0° 30'	ANGLE ± 0° 30'	Approved By:
FRACTIONS ± 1/16"	FRACTIONS ± 1/16"	Date: 11/12/10
INTERPRET THIS DRAWING IN ACCORDANCE WITH ANSI/ASME Y14.5-2009	TITLE: TORREX INSTALLATION DRAWING WITH PUMP AND VAPOR BYPASS	Scale: 1:20 AND NOTED
THIS DRAWING SHALL NOT BE REPRODUCED OR USED IN ANY MANNER WITHOUT THE WRITTEN INTERESTS. ALL RIGHTS RESERVED. © COP'RCHT ALGAS.SDI	Part #: A.S.D.I. STD.	Job #:
	151 S. Michigan St., Seattle, Washington, USA 98108	
	Tel: (206) 789-5410 Fax: (206) 789-5414	
Size: B	Dwg. #: 5001-8001	Sht. No.: 1 of 1
		Rev.: B

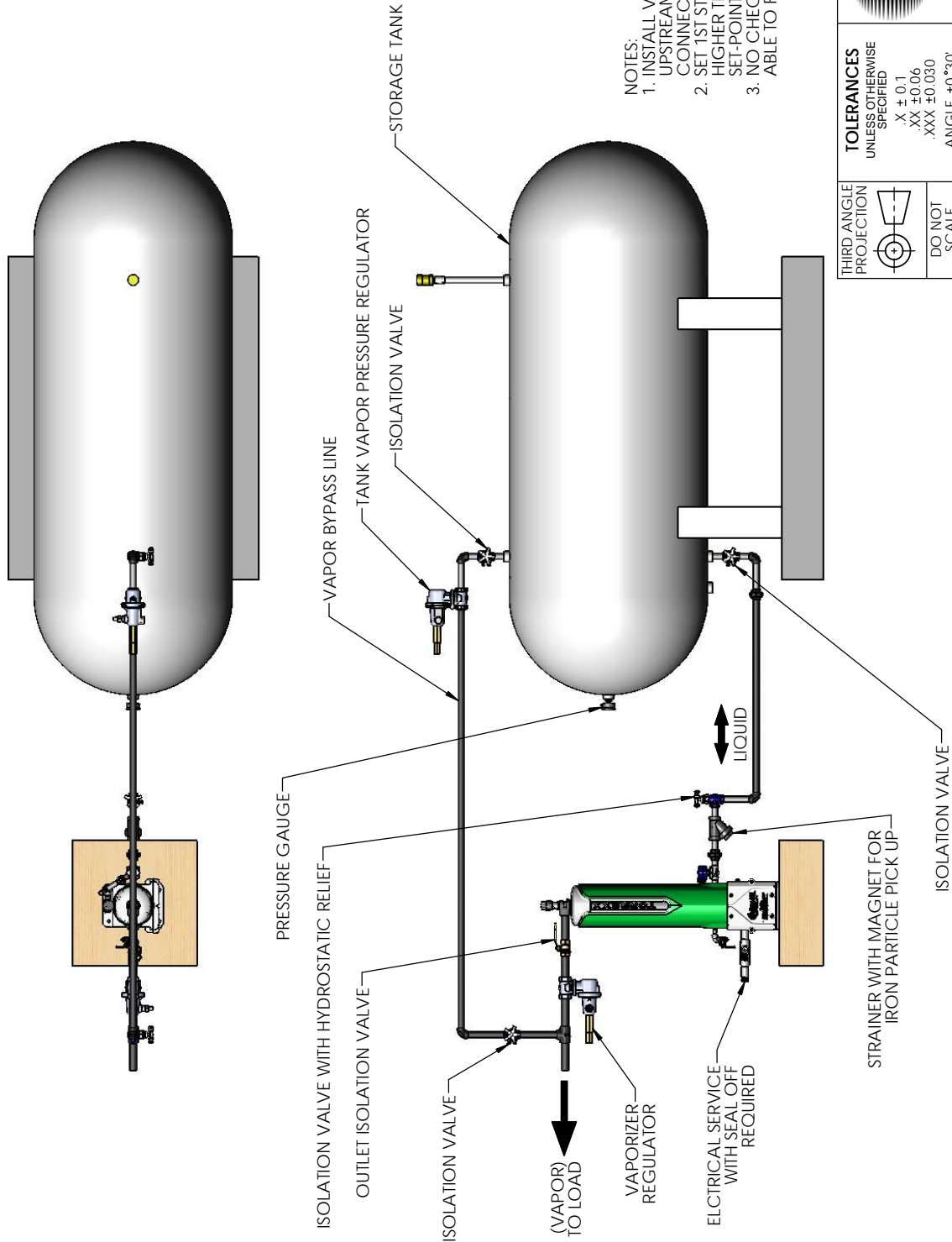

- NOTES:
1. INSTALL VAPORIZER 1ST STAGE REGULATOR UPSTREAM OF THE TANK VAPOR PRESSURE CONNECTION POINT.
 2. SET 1ST STAGE VAPORIZER REGULATOR 2-4 PSIG HIGHER THAN TANK VAPOR PRESSURE REGULATOR SET-POINT.
 3. NO CHECK VALVES IN LIQUID LINE. LIQUID MUST BE ABLE TO FLOW IN BOTH DIRECTIONS.

THIRD ANGLE PROJECTION 	TOLERANCES UNLESS OTHERWISE SPECIFIED X ± 0.1 XX ± 0.06 .XXX ± 0.030 ANGLE ± 0°30' FRACTIONS ± 1/16" <small>INTERPRET THIS DRAWING IN ACCORDANCE WITH ANSI Z39.5-2009</small>	 151 S. Michigan St., Seattle, Washington, USA 98108 Tel: (206) 789-5410 Fax: (206) 789-5414 Part # _____	Drawn By: A. EIGLIOL Checked By: DN Approved By: _____ Date: 11/18/10
			Scale: 1:20 AND NOTED Job # _____ Part # _____ Title: TORREXX INSTALLATION WITH VAPOR BYPASS AND NO PUMP

THIS DRAWING SHALL NOT BE REPRODUCED OR USED IN ANY MANNER WITHOUT THE WRITTEN INTERESTS. ALL RIGHTS RESERVED. © COPYRIGHT ALGAS-SDI

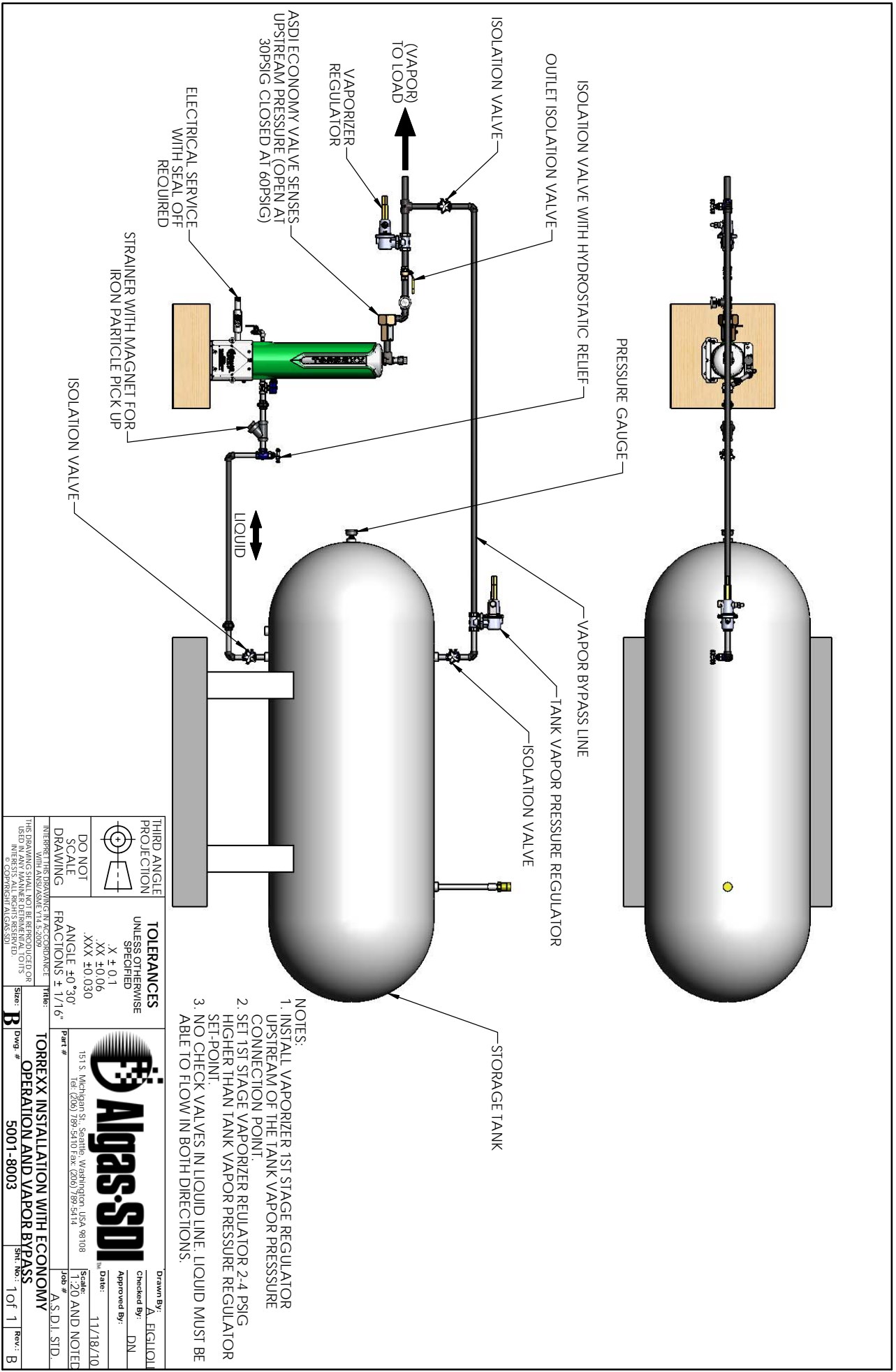

- NOTES:
1. INSTALL VAPORIZER 1ST STAGE REGULATOR UPSTREAM OF THE TANK VAPOR PRESSURE CONNECTION POINT.
 2. SET 1ST STAGE VAPORIZER REGULATOR 2-4 PSIG HIGHER THAN TANK VAPOR PRESSURE REGULATOR SET-POINT.
 3. NO CHECK VALVES IN LIQUID LINE. LIQUID MUST BE ABLE TO FLOW IN BOTH DIRECTIONS.

<p>THIRD ANGLE PROJECTION</p>	<p>TOLERANCES UNLESS OTHERWISE SPECIFIED</p> <p>X ± 0.1</p> <p>XX ± 0.06</p> <p>XXX ± 0.030</p> <p>FRACTIONS ± 1/16"</p>	<p>DO NOT SCALE DRAWING</p> <p>INTERPRET THIS DRAWING IN ACCORDANCE WITH ANSISAVE Y14.5:2009</p> <p>THIS DRAWING SHALL NOT BE REPRODUCED OR USED IN ANY MANNER WITHOUT THE WRITTEN INTERESTS. ALL RIGHTS RESERVED. © COPYRIGHT ALGAS SDI</p>
<p>Part #</p> <p>151 S. Michigan St., Seattle, Washington, USA 98108</p> <p>Tel: (206) 789-5410 Fax: (206) 789-5414</p>	<p>Scale: 1:20 AND NOTE</p> <p>Date: 11/18/10</p>	<p>Job # A.S.D.I. STD.</p>
<p>Drawn By: A. FIGLIOLI</p> <p>Checked By: DN</p> <p>Approved By:</p>	<p>Part #</p> <p>TORREXX INSTALLATION WITH ECONOMY OPERATION AND VAPOR BYPASS</p>	<p>Sheet No.: 1 of 1</p> <p>Rev.: B</p>

Algas-SDI

151 S. Michigan St., Seattle, Washington, USA 98108
Tel: (206) 789-5410 Fax: (206) 789-5414

Scale: 1:20 AND NOTE
Date: 11/18/10

Job # A.S.D.I. STD.

Drawn By: A. FIGLIOLI
Checked By: DN
Approved By:

Part # TORREXX INSTALLATION WITH ECONOMY OPERATION AND VAPOR BYPASS

Sheet No.: 1 of 1
Rev.: B

SOLENOID NOISE

Solenoid valves emit a sound when operated. When energized, they emit a clicking sound. Also, accompanying the operation of most AC valves, is AC hum. Whether or not AC hum is objectionable actually depends on the requirements and opinion of the user. Normal AC hum is the result of the constantly reversing magnetic field produced by alternating current. The constantly reversing magnetic field can cause vibrations in the solenoid parts.

1. Solenoid noise due to damage solenoid parts such as bent solenoid base assembly, stretched return springs, loose parts, etc.

Solution: Inspect valve internals and exterior. Replaced damaged parts.

2. Solenoid noise due to foreign matter between the core and plug-nut. When foreign matter is trapped between the core and plug-nut, the core assembly will rock back and forth at 60 hertz. Eventually, the core and plug-nut face will be distorted, at which time the noise can continue even though the foreign material may have been flushed or removed from the valve.

Solution: Replace damaged parts entirely, clean and reassemble.

3. Solenoid noise due to damaged coil. On rare occasions, a severe voltage spike or over voltage can potentially short a small portion of the coil winding. This shorting can cause solenoid noise and coil overheating. However, it would normally lead to rapid coil burnout. The solenoid parts, however, could be damaged enough that the noise would continue even after the coil was replaced due to the deformation produced during the peening process.
4. Missing solenoid parts can severely weaken the magnetic circuit. This can produce a solenoid noise condition. As discussed above, it will probably also result in coil burn-out.

Solution: Replace damaged parts, replace lost parts, clean and re-assemble.

In general, when a noise condition has been encountered, the source of the problem should be determined and eliminated. The valve should then be thoroughly inspected to insure that it is yet repairable. Most times, simple installation of a spare parts kit and a solenoid base sub assembly can restore a valve to like new condition. The restored and reinstalled solenoid valve should be tested to insure proper operation, and a voltage check should be made at the solenoid valve while the valve is energized. In addition, a current reading can be obtained and compared with catalog specifications to verify normal solenoid and coil operation.

Note: The coil may have been damaged due to excessive current draw of at damaged shading coil within the solenoid valve. A partial rebuilding of a valve damaged by a noise condition can prove useless as the noise condition would continue. The entire valve should be dismantled and inspected and cleaned. All parts supplied in a spare parts kit should be installed. Further, and additional solenoid parts damaged by a noise condition such as a solenoid base sub assembly, should be replaced. Examine valve seating, pistons and the valve body to verify that they have not been damaged. Damage to major portions of the valve may make repairing the valve uneconomical.

Should a noise condition be encountered, immediate action may prevent any damage to the solenoid valve itself.

ASCO Valve used by Algas-SDI

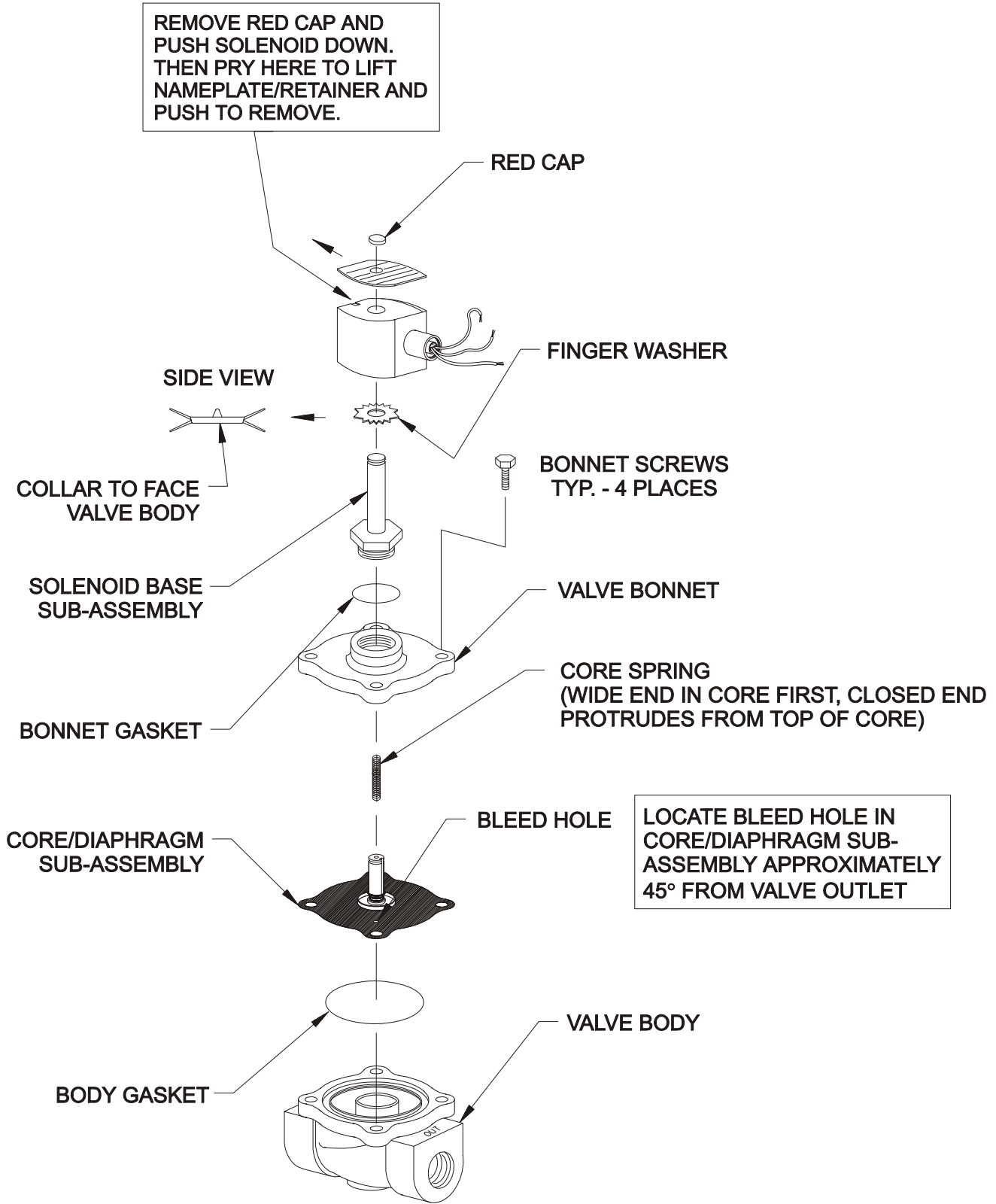

Installation & Maintenance Instructions

2-WAY INTERNAL PILOT-OPERATED SOLENOID VALVES HUNG DIAPHRAGM — 3/8, 1/2 AND 3/4 NPT NORMALLY CLOSED OPERATION

BULLETINS

8210

8211

Form No.V5825R1

DESCRIPTION

Bulletin 8210's are 2-way, normally closed, internal pilot operated solenoid valves. Valve body and bonnet are of brass construction. Standard valves have a General Purpose, NEMA Type 1 Solenoid Enclosure.

Bulletin 8211's are the same as Bulletin 8210's except the solenoids are equipped with an enclosure which is designed to meet NEMA Type 4 Watertight, NEMA Type 7 (C or D) Hazardous Locations - Class I, Group C or D, and NEMA Type 9 (E, F or G) Hazardous Locations - Class II, Group E, F or G. The explosion-proof/watertight solenoid enclosure is shown on a separate sheet of Installation and Maintenance Instructions, Form No. V-5380.

Bulletin 8210 and 8211 valves with suffix 'HW' in the catalog number are specifically designed for hot water service.

OPERATION

Normally Closed: Valve is closed when solenoid is de-energized and opens when solenoid is energized.

MANUAL OPERATOR (Optional)

Valves with suffix 'MO' in catalog number are provided with a manual operator which allows manual operation when desired or during an interruption of electrical power. To operate valve manually, push in knurled cap and rotate clockwise 180°. Disengage manual operator by rotating knurled cap counterclockwise 180° before operating electrically.

MANUAL OPERATOR LOCATION (Refer to Figure 3)

Manual operator (when shipped from factory) will be located over the valve outlet. Manual operator may be relocated at 90° increments by rotating valve bonnet. Remove bonnet screws (4) and rotate valve bonnet with solenoid to desired position. Replace bonnet screws (4) and torque in a crisscross manner to 110 ± 10 inch pounds.

If valve is installed in system and is operational, proceed in the following manner:

WARNING: Depressurize valve and turn off electrical power supply.

1. Remove retaining cap or clip and slip the entire solenoid enclosure off the solenoid base sub-assembly. CAUTION: When metal retaining clip disengages, it will spring upwards.
2. Remove bonnet screws (4) and rotate valve bonnet to desired position.
3. Replace bonnet screws (4) and torque in a crisscross manner to 110 ± 10 inch pounds.
4. Replace solenoid enclosure and retaining clip or cap.

INSTALLATION

Check nameplate for correct catalog number, pressure, voltage and service.

TEMPERATURE LIMITATIONS

For maximum valve ambient and fluid temperatures refer to chart. The temperature limitations listed are for UL applications. For non UL applications, higher ambient and fluid temperature limitations are available. Consult factory. Check catalog number on nameplate to determine maximum temperatures.

Construction	Coil Class	Catalog Number Prefix	Maximum Ambient Temp. °F.	Maximum Fluid Temp. °F.
A-C Construction (Alternating Current)	A	None or DA	77	180
	F	DF or FT	122	180
	H	HT	140	180
D-C Construction (Direct Current)	A, F or H	None, FT or HT	77	150
Catalog Numbers Suffixed 'HW' A-C Construction (Alternating Current)	A	None or DA	77	210
	F	DF or FT	77	210
	H	HT	122	210

POSITIONING/MOUNTING

Valve may be mounted in any position. For mounting bracket (optional feature) dimensions, refer to Figure 1.

PIPING

Connect piping to valve according to markings on valve body. Apply pipe compound sparingly to male pipe threads only; if applied to valve threads, it may enter the valve and cause operational difficulty. Pipe strain should be avoided by proper support and alignment of piping. When tightening the pipe do not use valve as a lever. Wrenches applied to valve body or piping are to be located as close as possible to connection point. **IMPORTANT: Valves with suffix 'HW' in the catalog number have a special diaphragm material which is specifically compounded for hot water service. This material can be attacked by oil and grease. Wipe the pipe threads clean of cutting oils and use teflon tape to seal pipe joints.**

IMPORTANT: For the protection of the solenoid valve, install a strainer or filter suitable for the service involved in the inlet side as close to the valve as possible. Periodic cleaning is required depending on the service conditions. See Bulletins 8600, 8601 and 8602 for strainers.

WIRING

Wiring must comply with Local and National Electrical Codes. Housings for all solenoids are provided with connections for 1/2 inch conduit. The general purpose solenoid enclosure may be rotated to facilitate wiring by removing the retaining cap or clip. CAUTION: When metal retaining clip disengages it will spring upwards. Rotate to desired position. Replace retaining cap or clip before operating.

NOTE: Alternating Current (A-C) and Direct Current (D-C) Solenoids are built differently. To convert from one to the other, it is necessary to change the complete solenoid including the solenoid base sub-assembly and core assembly.

SOLENOID TEMPERATURE

Standard catalog valves are supplied with coils designed for continuous duty service. When the solenoid is energized for a long period, the solenoid enclosure becomes hot and can be touched with the hand for only an instant. This is a safe operating temperature. Any excessive heating will be indicated by the smoke and odor of burning coil insulation.

MAINTENANCE

WARNING: Turn off electrical power and depressurize valve before making repairs. It is not necessary to remove valve from pipe line for repairs.

CLEANING

A periodic cleaning of all solenoid valves is desirable. The time between cleanings will vary, depending on media and service conditions. In general, if the voltage to the coil is correct, sluggish valve operation, excessive leakage or noise will indicate that cleaning is required.

PREVENTIVE MAINTENANCE

1. Keep the medium flowing through the valve as free from dirt and foreign material as possible.
2. While in service, operate valve at least once a month to insure proper opening and closing.
3. Periodic inspection (depending on media and service conditions) of internal valve parts for damage or excessive wear is recommended. Thoroughly clean all parts. Replace any parts that are worn or damaged.

IMPROPER OPERATION

1. **Faulty Control Circuit:** Check electrical system by energizing solenoid. A metallic click signifies the solenoid is operating. Absence of the click indicates loss of power supply. Check for loose or blown-out fuses, open circuited or grounded coil, broken lead wires or splice connections.
2. **Burned-Out Coil:** Check for open circuited coil. Replace coil if necessary.
3. **Low Voltage:** Check voltage across coil leads. Voltage must be at least 85% of nameplate rating.
4. **Incorrect Pressure:** Check valve pressure. Pressure to the valve must be within range specified on nameplate.
5. **Excessive Leakage:** Disassemble valve and clean all parts. Replace worn or damaged parts with a complete Spare Parts Kit for best results.

COIL REPLACEMENT (Refer to Figure 2)

Turn off electrical power supply and disconnect coil leads. Proceed in the following manner:

1. Remove retaining cap or clip, nameplate and cover. CAUTION: When metal retaining clip disengages, it will spring upwards.
2. Remove spring washer, insulating washer and coil. Insulating washers are omitted when a molded coil is used.
3. Reassemble in reverse order of disassembly paying careful attention to exploded view provided for identification and placement of parts.

CAUTION: Solenoid must be fully reassembled as the housing and internal parts are part of and complete the magnetic circuit. Place insulating washer at each end of coil if required.

VALVE DISASSEMBLY (Refer to Figures 2 and 3)

Depressurize valve and turn off electrical power supply. Proceed in the following manner:

1. Remove retaining cap or clip and slip the entire solenoid enclosure off the solenoid base sub-assembly. CAUTION: When metal retaining clip disengages, it will spring upwards.
2. Unscrew solenoid base sub-assembly and remove bonnet gasket.
3. Remove valve bonnet screws (4) and valve bonnet.
4. For normal maintenance, it is not necessary to disassemble the manual operator (optional feature) unless external leakage is evident. To disassemble remove stem pin, manual operator stem, stem spring and stem gasket.
5. Remove core spring, core/diaphragm sub-assembly and body gasket. CAUTION: Do not damage or distort hanger spring between core/diaphragm sub-assembly.
6. All parts are now accessible for cleaning or replacement. Replace worn or damaged parts with a complete Spare Parts Kit for best results.

VALVE REASSEMBLY

1. Reassemble in reverse order of disassembly paying careful attention to exploded views provided for identification and placement of parts.
2. Replace body gasket and core/diaphragm sub-assembly. Locate the bleed hole in core/diaphragm sub-assembly approximately 45° from the valve outlet.
3. Replace core spring with wide end in core first; closed end protrudes from top of core.
4. If removed, replace manual operator stem, stem spring, stem gasket and stem pin.
5. Replace valve bonnet and bonnet screws (4). Torque bonnet screws (4) in a crisscross manner to 110 ± 10 inch pounds.
6. Replace bonnet gasket and solenoid base sub-assembly. Put solenoid base sub-assembly to 175 ± 25 inch pounds.
7. Replace solenoid enclosure and retaining cap or clip.
8. After maintenance, operate the valve a few times to be sure of proper opening and closing.

SPARE PARTS KITS

Spare Parts Kits and Coils are available for ASCO valves. Parts marked with an asterisk (*) are supplied in Spare Parts Kits.

ORDERING INFORMATION FOR SPARE PARTS KITS

When Ordering Spare Parts Kits or Coils Specify Valve Catalog Number, Serial Number and Voltage.

PARTIAL VIEW OF MOUNTING BRACKET (OPTIONAL)

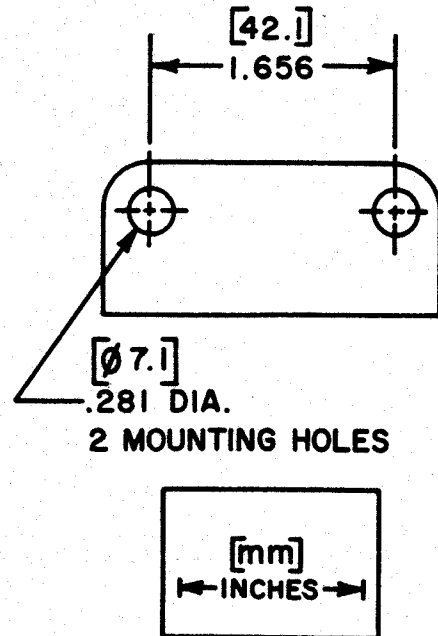

Dimensions For Mounting Bracket (Optional Feature)

Figure 1.

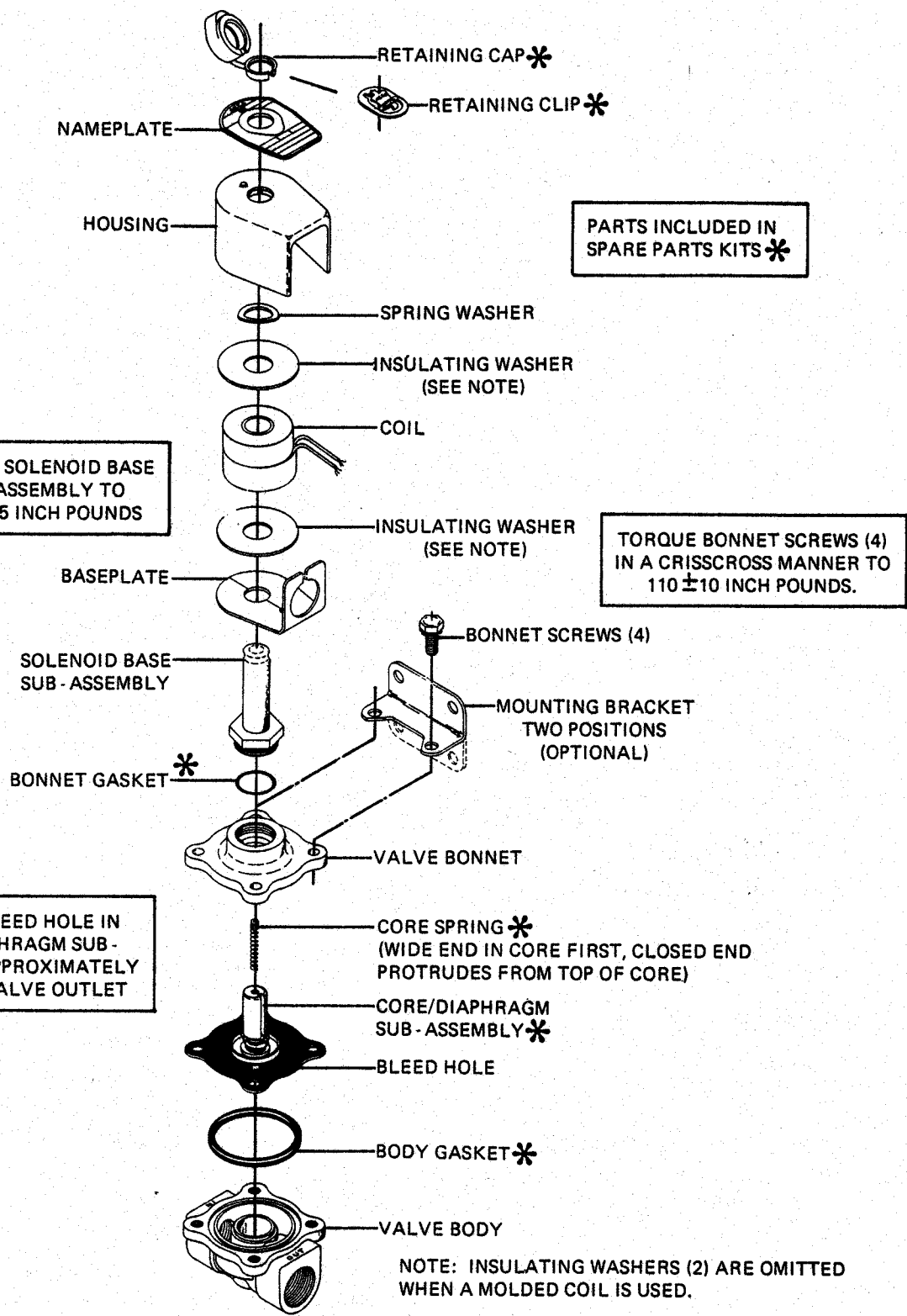

Bulletin 8210 — 3/8, 1/2 & 3/4 N.P.T. — A-C Construction
 General purpose solenoid enclosure shown.

For explosion-proof/watertight solenoid enclosure used on Bulletin 8211, see Form No. V-5380.

Figure 2.

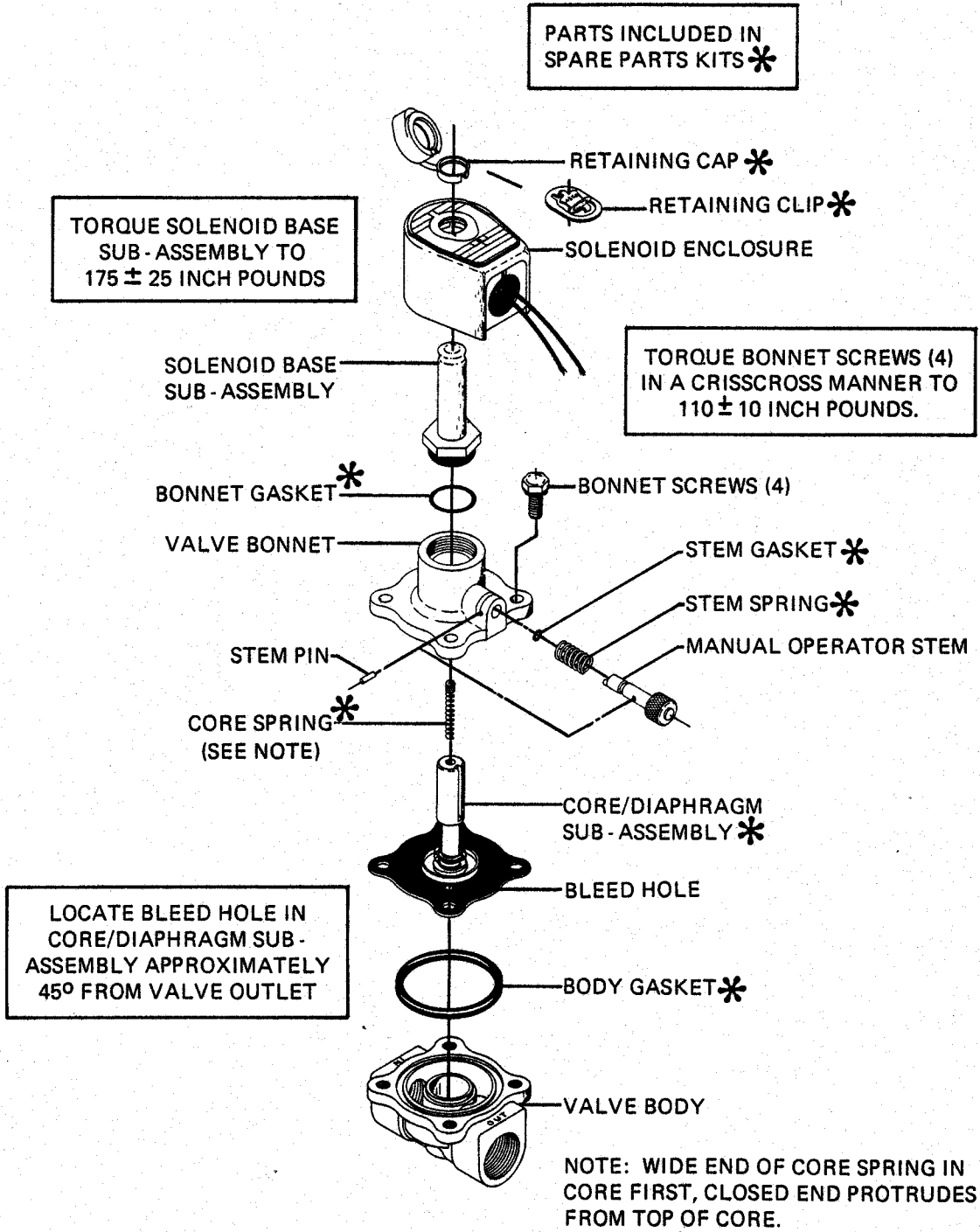

Figure 3.

Bulletin 8210 — Manual Operator
 General purpose solenoid enclosure shown.
 For explosion-proof/watertight solenoid enclosure used on Bulletin 8211, see Form No. V-5380.

Installation & Maintenance Instructions



OPEN-FRAME, GENERAL PURPOSE, WATERTIGHT/EXPLOSIONPROOF SOLENOIDS

SERIES

8003G

8202G

Form No.V6584R8

— SERVICE NOTICE —

ASCO® solenoid valves with design change letter “G” or “H” in the catalog number (ex. 8210G 1) have an epoxy encapsulated ASCO® Red Hat II® solenoid. This solenoid replaces some of the solenoids with metal enclosures and open-frame constructions. Follow these installation and maintenance instructions if your valve or operator uses this solenoid.

See separate instructions for basic valve.

DESCRIPTION

Catalog numbers 8003G and 8202G are epoxy encapsulated pull-type solenoids. The green solenoid with lead wires and 1/2" conduit connection is designed to meet Enclosure Type 1—General Purpose, Type 2—Dripproof, Types 3 and 3S—Raintight, and Types 4 and 4X—Watertight. The black solenoid on catalog numbers prefixed “EF” or “EV” is designed to meet Enclosure Types 3 and 3S—Raintight, Types 4 and 4X—Watertight, Types 6 and 6P—Submersible, Type 7 (A, B, C & D) Explosionproof Class I, Division 1 Groups A, B, C, & D and Type 9 (E, F, & G)—Dust—Ignitionproof Class II, Division 1 Groups E, F & G. The Class II, Groups F & G Dust Locations designation is not applicable for solenoids or solenoid valves used for steam service or when a class “H” solenoid is used. See *Temperature Limitations* section for solenoid identification and nameplate/retainer for service. When installed just as a solenoid and not attached to an ASCO valve, the core has a 0.250–28 UNF–2B tapped hole, 0.38 or 0.63 minimum full thread.

NOTE: Catalog number prefix “EV” denotes stainless steel construction.

Catalog numbers 8202G1, 8202G3, 8202G5 and 8202G7 are epoxy encapsulated push-type, reverse-acting solenoids having the same enclosure types as previously stated for Catalog numbers 8003G1 and 8003G2.

Series 8003G and 8202G solenoids are available in:

- **Open-Frame Construction:** The green solenoid may be supplied with 1/4" spade, screw or DIN terminals. (Refer to Figure 4)
- **Panel Mounted Construction:** These solenoids are specifically designed to be panel mounted by the customer through a panel having a .062 to .093 maximum wall thickness. Refer to Figure 1 and section on *Installation of Panel Mounted Solenoid*.

Optional Features For Type 1 – General Purpose Construction Only

- **Junction Box:** This junction box construction meets Enclosure Types 2,3,3S,4, and 4X. Only solenoids with 1/4" spade or screw terminals may have a junction box. The junction box provides a 1/2" conduit connection, grounding and spade or screw terminal connections within the junction box (See Figure 5).
- **DIN Plug Connector Kit No.K236034:** Use this kit only for solenoids with DIN terminals. The DIN plug connector kit provides a two pole with grounding contact DIN Type 43650 construction (See Figure 6).

OPERATION

Series 8003G – When the solenoid is energized, the core is drawn into the solenoid base sub-assembly. **IMPORTANT: When the solenoid is de-energized, the initial return force for the core, whether developed by spring, pressure, or weight, must exert a minimum force to overcome residual magnetism created by the solenoid. Minimum return force for AC construction is 11 ounces, and 5 ounces for DC construction.**

Series 8202G – When the solenoid is energized, the disc holder assembly seats against the orifice. When the solenoid is de-energized, the disc holder assembly returns. **IMPORTANT: Initial return force for the disc or disc holder assembly, whether developed by spring, pressure, or weight, must exert a minimum force to overcome residual magnetism created by the solenoid. Minimum return force is 1 pound, 5 ounces.**

INSTALLATION

Check nameplate for correct catalog number, service, and wattage. Check front of solenoid for voltage and frequency.

⚠ WARNING: Electrical hazard from the accessibility of live parts. To prevent the possibility of death, serious injury or property damage, install the open – frame solenoid in an enclosure.

FOR BLACK ENCLOSURE TYPES 7 AND 9 ONLY

⚠ CAUTION: To prevent fire or explosion, do not install solenoid and/or valve where ignition temperature of hazardous atmosphere is less than 165° C. On valves used for steam service or when a class “H” solenoid is used, do not install in hazardous atmosphere where ignition temperature is less than 180° C. See nameplate/retainer for service.

NOTE: These solenoids have an internal non-resettable thermal fuse to limit solenoid temperature in the event that extraordinary conditions occur which could cause excessive temperatures. These conditions include high input voltage, a jammed core, excessive ambient temperature or a shorted solenoid, etc. This unique feature is a standard feature only in solenoids with black explosionproof/dust-ignitionproof enclosures (Types 7 & 9).

⚠ CAUTION: To protect the solenoid valve or operator, install a strainer or filter, suitable for the service involved in the inlet side as close to the valve or operator as possible. Clean periodically depending on service conditions. See ASCO Series 8600, 8601, and 8602 for strainers.

Temperature Limitations

For maximum valve ambient temperatures, refer to chart. The temperature limitations listed, only indicate maximum application temperatures for field wiring rated at 90°C. Check catalog number prefix and watt rating on nameplate to determine maximum ambient temperature. See valve installation and maintenance instructions for maximum fluid temperature. NOTE: For steam service, refer to *Wiring* section, *Junction Box* for temperature rating of supply wires.

Temperature Limitations For Series 8003G or 8202G Solenoids for use on Valves Rated at 10.1, 11.6, 17.1, or 22.6 Watts			
Watt Rating	Catalog Number Coil Prefix	Class of Insulation	Maximum † Ambient Temp.
10.1 & 17.1	None, FB, KF, KP SC, SD, SF, & SP,	F	125°F (51.7°C)
10.1 & 17.1	HB, HT, KB, KH, SS, ST, SU,	H	140°F (60°C)
11.6 & 22.6	None, FB,KF, KP, SC, SD, SF, & SP.	F	104°F (40°C)
11.6 & 22.6	HP, HT, KB, KH, SS, ST, SU, & SV	H	104°F (40°C)

† Minimum ambient temperature –40° F (–40° C).

Positioning

This solenoid is designed to perform properly when mounted in any position. However, for optimum life and performance, the solenoid should be mounted vertically and upright to reduce the possibility of foreign matter accumulating in the solenoid base sub-assembly area.

Wiring

Wiring must comply with local codes and the National Electrical Code. All solenoids supplied with lead wires are provided with a grounding wire which is green or green with yellow stripes and a 1/2" conduit connection. To

facilitate wiring, the solenoid may be rotated 360°. For the watertight and explosionproof solenoid, electrical fittings must be approved for use in the approved hazardous locations.

▲ CAUTION: Cryogenic Applications – Solenoid lead wire insulation should not be subjected to cryogenic temperatures. Adequate lead wire protection and routing must be provided.

Additional Wiring Instructions For Optional Features:

- **Open–Frame solenoid with 1/4" spade terminals.**

For solenoids supplied with screw terminal connections use #12–18 AWG stranded copper wire rated at 90°C or greater. Torque terminal block screws to 10 ± 2 in–lbs [1,0 ± 1,2 Nm]. A tapped hole is provided in the solenoid for grounding, use a #10–32 machine screw. Torque grounding screw to 15 – 20 in–lbs [1,7 – 2,3 Nm]. On solenoids with screw terminals, the socket head screw holding the terminal block to the solenoid is the grounding screw. Torque the screw to 15 – 20 in–lbs [1,7 – 2,3 Nm] with a 5/32" hex key wrench.

- **Junction Box**

The junction box is used with spade or screw terminal solenoids only and is provided with a grounding screw and a 1/2" conduit connection. Connect #12–18 AWG standard copper wire only to the screw terminals. Within the junction box use field wire that is rated 90°C or greater for connections. For steam service use 105°C rated wire up to 50 psi or use 125°C rated wire above 50 psi. After electrical hookup, replace cover gasket, cover, and screws. Tighten screws evenly in a crisscross manner.

- **DIN Plug Connector Kit No.K236034**

1. The open–frame solenoid is provided with DIN terminals to accommodate the plug connector kit.
2. Remove center screw from plug connector. Using a small screwdriver, pry terminal block from connector cover.
3. Use #12–18 AWG stranded copper wire rated at 90°C or greater for connections. Strip wire leads back approximately 1/4" for installation in socket terminals. The use of wire–end sleeves is also recommended for these socket terminals. Maximum length of wire–end sleeves is not recommended.
4. Thread wire through gland nut, gland gasket, washer and connector cover. NOTE: Connector housing may be rotated in 90° increments from position shown for alternate positioning of cable entry.
5. Check DIN connector terminal block for electrical markings. Then make electrical hookup to terminal block according to markings on it. Snap terminal block into connector cover and install center screw.
6. Position connector gasket on solenoid and install plug connector. Torque center screw to 5 ± 1 in–lbs [0,6 ± 1,1 Nm].

NOTE: Alternating current (AC) and direct current (DC) solenoids are built differently. To convert from one to the other, it may be necessary to change the complete solenoid including the core and solenoid base sub–assembly, not just the solenoid. Consult ASCO.

Installation of Solenoid

Solenoids may be assembled as a complete unit. Tightening is accomplished by means of a hex flange at the base of the solenoid.

Installation of Panel Mounted Solenoid (See Figure 1)

1. Disassemble solenoid following instruction under *Solenoid Replacement* then proceed.
2. Install solenoid base sub–assembly through customer panel.
3. Position spring washer on opposite side of panel over solenoid base sub–assembly.
4. Replace solenoid, nameplate/retainer and red cap.
5. Make electrical hookup, see *Wiring* section.

Solenoid Temperature

Standard solenoids are designed for continuous duty service. When the solenoid is energized for a long period, the solenoid becomes hot and can be touched by hand only for an instant. This is a safe operating temperature.

MAINTENANCE

▲ WARNING: To prevent the possibility of death, serious injury or property damage, turn off electrical power, depressurize solenoid operator and/or valve, and vent fluid to a safe area before servicing.

Cleaning

All solenoid operators and valves should be cleaned periodically. The time between cleaning will vary depending on medium and service conditions. In general, if the voltage to the solenoid is correct, sluggish valve operation, excessive noise or leakage will indicate that cleaning is required. Clean strainer or filter when cleaning the valve.

Preventive Maintenance

- Keep the medium flowing through the solenoid operator or valve as free from dirt and foreign material as possible.
- While in service, the solenoid operator or valve should be operated at least once a month to insure proper opening and closing.
- Depending on the medium and service conditions, periodic inspection of internal valve parts for damage or excessive wear is recommended. Thoroughly clean all parts. Replace any worn or damaged parts.

Causes of Improper Operation

- **Faulty Control Circuit:** Check the electrical system by energizing the solenoid. A metallic *click* signifies that the solenoid is operating. Absence of the *click* indicates loss of power supply. Check for loose or blown fuses, open–circuited or grounded solenoid, broken lead wires or splice connections.
- **Burned–Out Solenoid:** Check for open–circuited solenoid. Replace if necessary. Check supply voltage; it must be the same as specified on nameplate/retainer and marked on the solenoid. Check ambient temperature and check that the core is not jammed.
- **Low Voltage:** Check voltage across the solenoid leads. Voltage must be at least 85% of rated voltage.

Solenoid Replacement

1. Disconnect conduit, coil leads, and grounding wire.
NOTE: Any optional parts attached to the old solenoid must be reinstalled on the new solenoid. For 3–way construction, piping or tubing must be removed from pipe adapter.
2. Disassemble solenoids with optional features as follows:
 - **Spade or Screw Terminals**
Remove terminal connections, grounding screw, grounding wire, and terminal block (screw terminal type only).
NOTE: For screw terminals, the socket head screw holding the terminal block serves as a grounding screw.
 - **Junction Box**
Remove conduit and socket head screw (use 5/32" hex key wrench) from center of junction box. Disconnect junction box from solenoid.
 - **DIN Plug Connector**
Remove center screw from DIN plug connector. Disconnect DIN plug connector from adapter. Remove socket head screw (use 5/32" hex key wrench), DIN terminal adapter, and gasket from solenoid.
3. Snap off red cap from top of solenoid base sub–assembly. For 3–way construction with pipe adapter (Figure 3), remove pipe adapter, nameplate and solenoid. Omit steps 4 and 5.
4. Push down on solenoid. Then using a suitable screwdriver, insert blade between solenoid and nameplate/retainer. Pry up slightly and push to remove.
NOTE: Series 8202G solenoids have a spacer between the nameplate/retainer and solenoid.
5. Remove solenoid from solenoid base sub–assembly.
6. Reassemble in reverse order of disassembly. Use exploded views for identification and placement of parts.
7. Torque pipe adapter to 90 inch–pounds maximum [10,2 Nm maximum]. Then make up piping or tubing to pipe adapter on solenoid.

Disassembly and Reassembly of Solenoids

1. Remove solenoid, see *Solenoid Replacement*.
2. Remove spring washer from solenoid base sub–assembly. For 3–way construction, remove plugnut gasket.
3. Unscrew solenoid base sub–assembly from valve body.
4. Remove internal solenoid parts for cleaning or replacement. Use exploded views for identification and placement of parts.
5. If the solenoid is part of a valve, refer to basic valve installation and maintenance instructions for further disassembly.
6. Torque solenoid base sub–assembly and adapter to 175±25 in–lbs [19,8±2,8 Nm].

ORDERING INFORMATION FOR ASCO SOLENOIDS

When Ordering Solenoids for ASCO Solenoid Operators or Valves, order the number stamped on the solenoid. Also specify voltage and frequency.

Torque Chart

Part Name	Torque Value Inch-Pounds	Torque Value Newton-Meters
solenoid base sub-assembly & adapter	175 ± 25	19,8 ± 2,8
pipe adapter	90 maximum	10,2 maximum

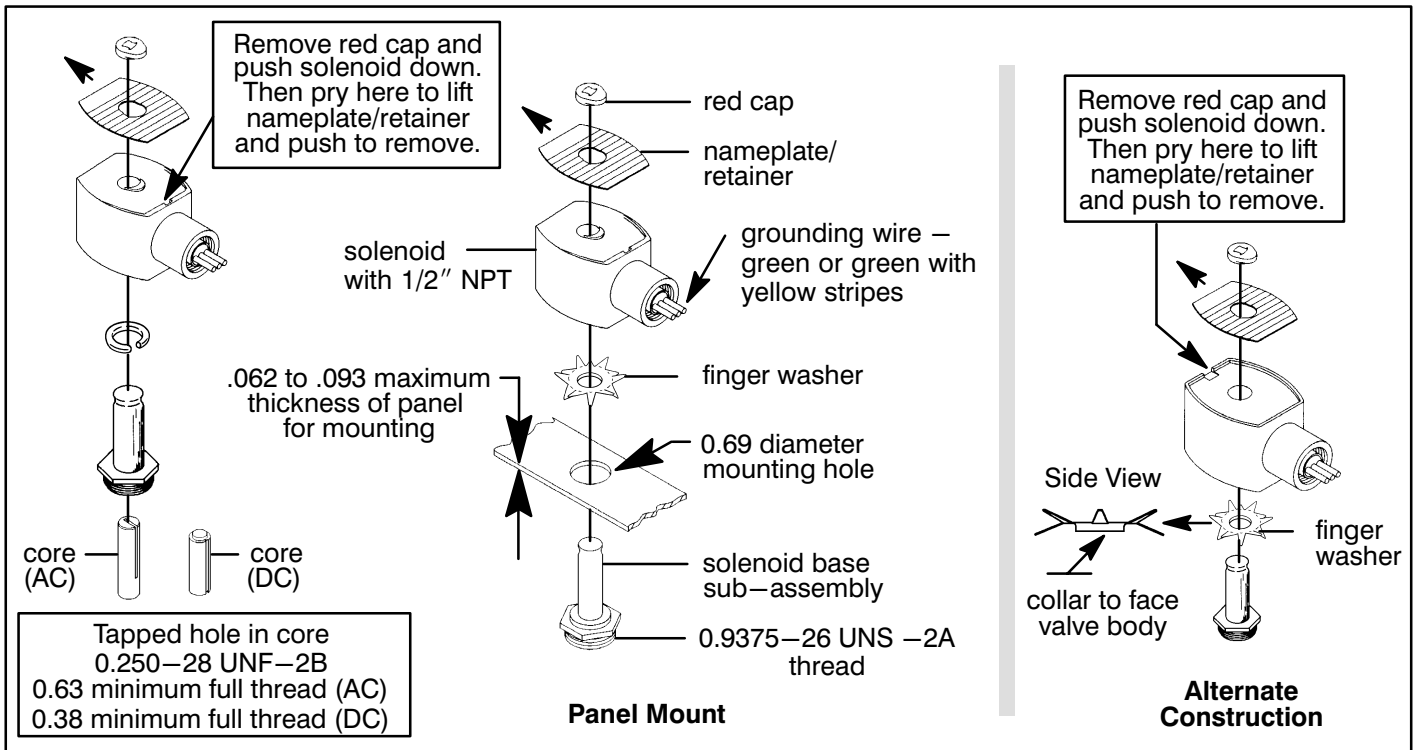

Figure 1. Series 8003G solenoids

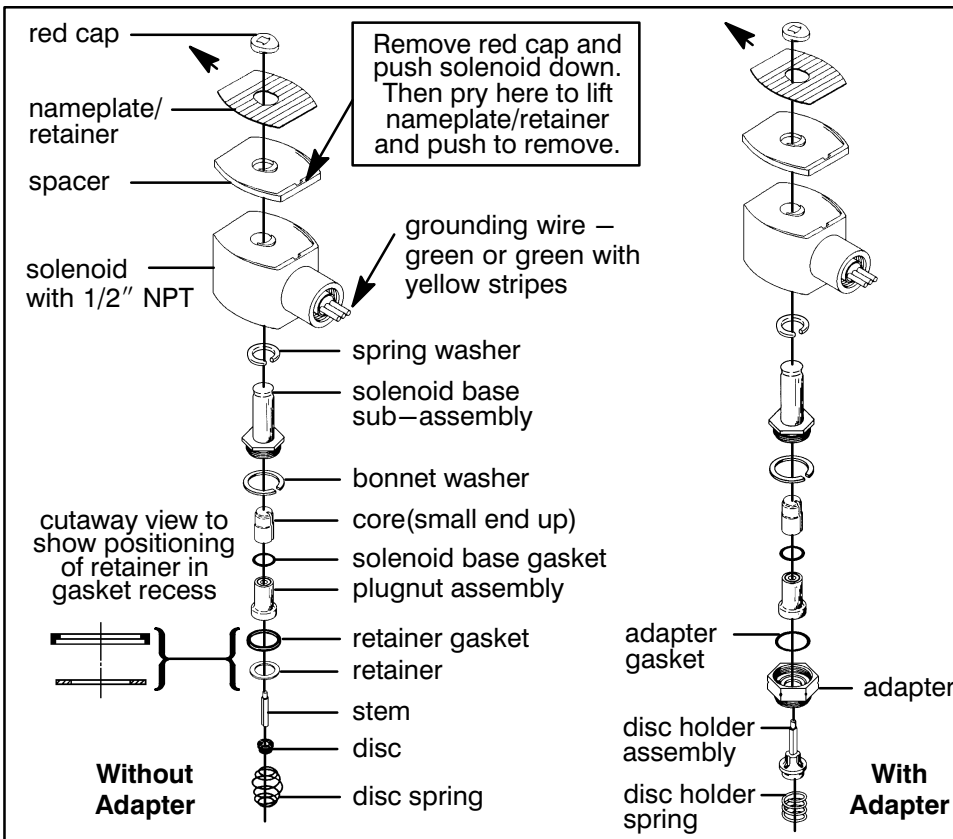

Figure 2. Series 8202G solenoids

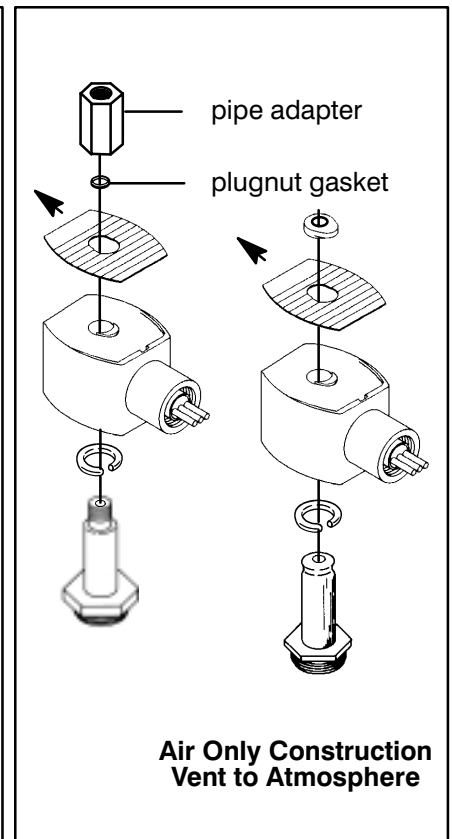

Figure 3. 3-Way Construction

Torque Chart

Part Name	Torque Value in Inch-Pounds	Torque Value in Newton-Meters
terminal block screws	10 ± 2	1,1 ± 0,2
socket head screw	15 – 20	1,7 – 2,3
center screw	5 ± 1	0,6 ± 0,1

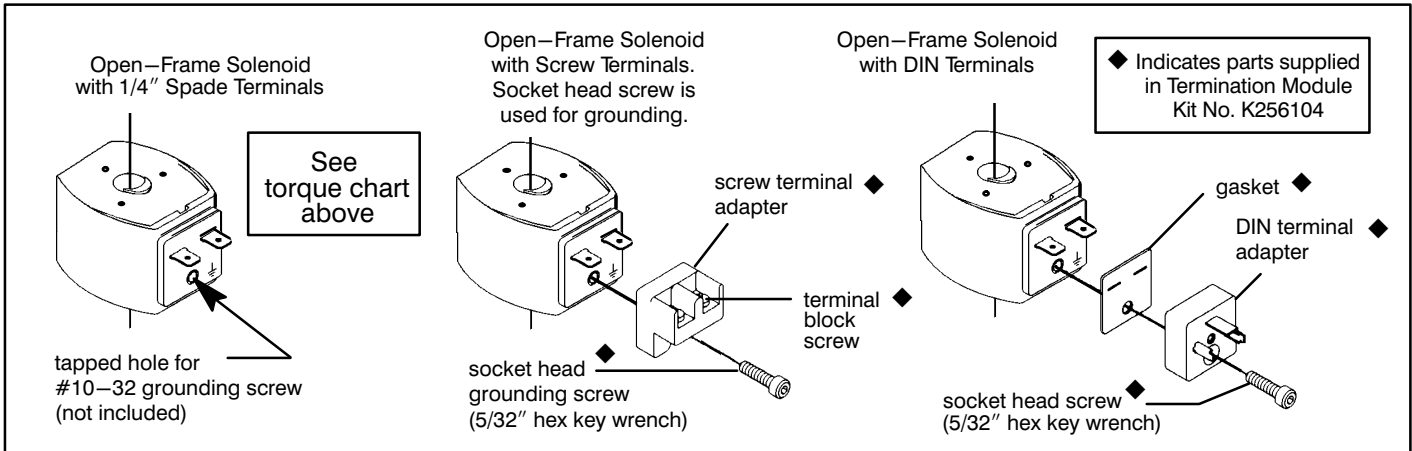

Figure 4. Open-frame solenoids

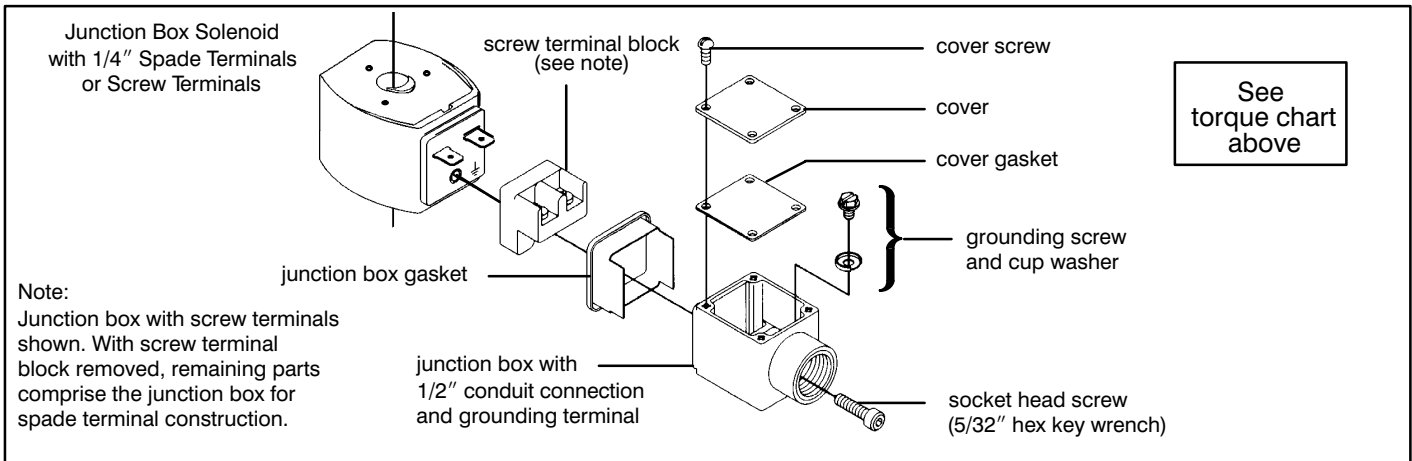

Figure 5. Junction box (optional feature)

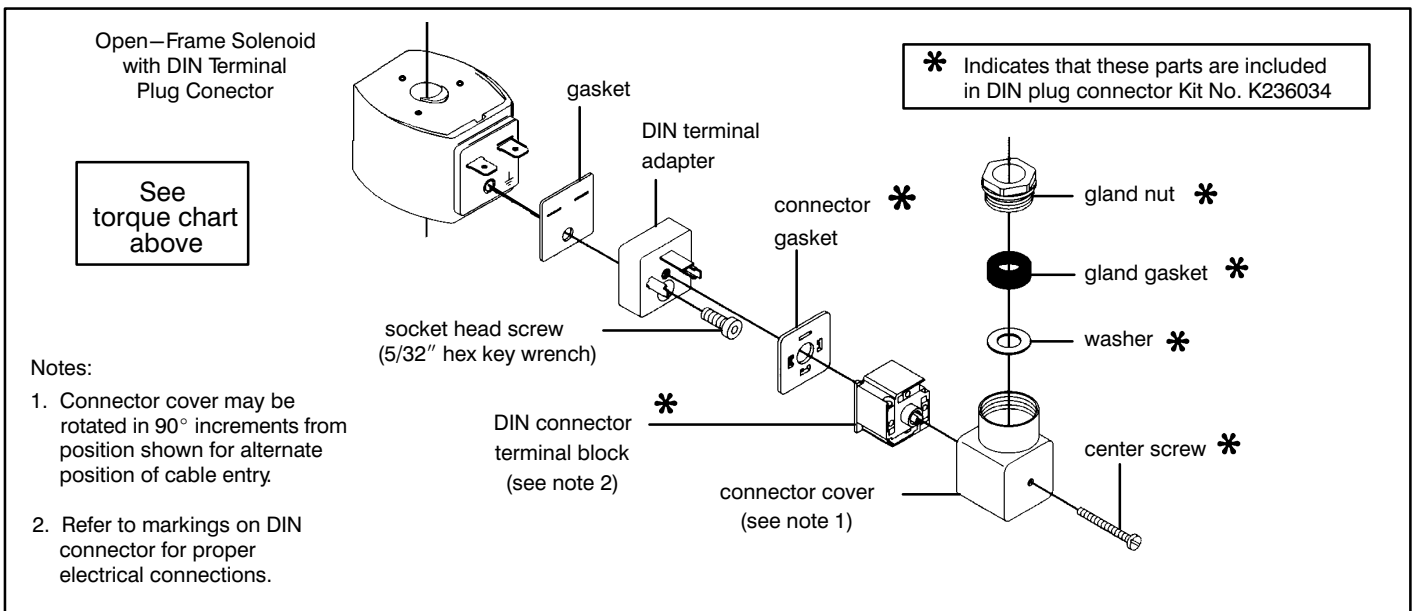

Figure 6. DIN plug connector kit No. K236034 (optional feature)



GENERAL INSTALLATION AND MAINTENANCE INSTRUCTIONS

Note: These General Installation and Maintenance Instructions must be read in conjunction with the instruction Sheet for the specific product.

INSTALLATION

ASCO/JOUCOMATIC components are intended to be used only within the technical characteristics as specified on the nameplate. Changes to the equipment are only allowed after consulting the manufacturer or its representative. Before installation depressurize the piping system and clean internally. The equipment may be mounted in any position if not otherwise indicated on the product by means of an arrow. The flow direction and pipe connection of valves are indicated on the body.

The pipe connections have to be in accordance with the size indicated on the nameplate and fitted accordingly.
Caution:

- Reducing the connections may cause improper operation or malfunctioning.
- For the protection of the equipment install a strainer or filter suitable for the service involved in the inlet side as close to the product as possible.
- If tape, paste, spray or a similar lubricant is used when tightening, avoid particles entering the system.
- Use proper tools and locate wrenches as close as possible to the connection point.
- To avoid damage to the equipment, DO NOT OVERTIGHTEN pipe connections.
- Do not use valve or solenoid as a lever.
- The pipe connections should not apply any force, torque or strain to the product.

ELECTRICAL CONNECTION

In case of electrical connections, they are only to be made by trained personnel and have to be in accordance with the local regulations and standards.

Caution:

- Turn off electrical power supply and de-energize the electrical circuit and voltage carrying parts before starting work.
- All electrical screw terminals must be properly tightened according to the standards before putting into service.
- Dependent upon the voltage electrical components must be provided with an earth connection and satisfy local regulations and standards

The equipment can have one of the following electrical terminals:

- Spade plug connections according to ISO-4400 or 3 x DIN-46244 (when correctly installed this connection provides IP-65 protection).
- Embedded screw terminals in metal enclosure with "Pg" cable gland.
- Spade terminals (AMP type).
- Flying leads or cables.

PUTTING INTO SERVICE

Before pressurizing the system, first carry-out an electrical test. In case of solenoid valves, energize the coil a few times and notice a metal click signifying the solenoid operation.

SERVICE

Most of the solenoid valves are equipped with coils for continuous duty service. To prevent the possibility of personal or property damage do not touch the solenoid which can become hot under normal operation conditions.

SOUND EMISSION

The emission of sound depends on the application, medium and nature of the equipment used. The exact determination of the sound level can only be carried out by the user having the valve installed in his system.

MAINTENANCE

Maintenance of ASCO/JOUCOMATIC products is dependent on service conditions. Periodic cleaning is recommended, the timing of which will depend on the media and service conditions. During servicing, components should be examined for excessive wear. A complete set of internal parts is available as a spare parts or rebuild kit. If a problem occurs during installation/maintenance or in case of doubt please contact ASCO/JOUCOMATIC or authorized representatives.

A separate Declaration of Incorporation relating to EEC-Directive 89/392/EEC Annex II B is available on request. Please provide product identification number and serial numbers of products concerned.

The product complies with the essential requirements of the EMC Directive 89/338/EEC and amendments and the Low Voltage directives 73/23/EEC and 93/68/EEC. A separate Declaration of Conformity is available on request. Please provide product identification number and serial numbers of the products concerned.



INSTRUCTIONS GÉNÉRALES D'INSTALLATION ET D'ENTRETIEN

Nota : Ces instructions générales d'installation et d'entretien complètent la notice spécifique du produit.

MONTAGE

Les composants ASCO/JOUCOMATIC sont conçus pour les domaines de fonctionnement indiqués sur la plaque signalétique ou la documentation. Aucune modification ne peut être réalisée sur le matériel sans l'accord préalable du fabricant ou de son représentant. Avant de procéder au montage, dépressuriser les canalisations et effectuer un nettoyage interne.

A moins qu'une flèche ou la notice n'indique un sens de montage spécifique de la tête magnétique, le produit peut être monté dans n'importe quelle position.

Le sens de circulation du fluide est indiqué par repères sur le corps et dans la documentation.

La dimension des tuyauteries doit correspondre au raccordement indiqué sur le corps, l'étiquette ou la notice.

Attention :

- Une restriction des tuyauteries peut entraîner des dysfonctionnements.
- Afin de protéger le matériel, installer une crépine ou un filtre adéquat en amont, aussi près que possible du produit.
- En cas d'utilisation de ruban, pâte, aérosol ou autre lubrifiant lors du serrage, veiller à ce qu'aucun corps étranger ne pénètre dans le circuit.
- Utiliser un outillage approprié et placer les clés aussi près que possible du point de raccordement.
- Afin d'éviter toute détérioration, NE PAS TROP SERRER les raccords des tuyauteries.
- Ne pas se servir de la vanne ou de la tête magnétique comme d'un levier.
- Les tubes de raccordement ne devront exercer aucun effort, couple ou contrainte sur le produit.

RACCORDEMENT ÉLECTRIQUE

Le raccordement électrique doit être réalisé par un personnel qualifié et selon les normes et règlements locaux.

Attention :

- Avant toute intervention, couper l'alimentation électrique pour mettre hors tension les composants.
- Toutes les bornes à vis doivent être serrées correctement avant la mise en service.
- Selon la tension, les composants électriques doivent être mis à la terre conformément aux normes et règlements locaux.

Selon les cas, le raccordement électrique s'effectue par :

- Connecteur débrochable ISO4400 ou 3 x DIN46244 avec degré de protection IP65 lorsque le raccordement est correctement effectué.
- Bornes à vis solidaires du bobinage, sous boîtier métallique avec presse-étoupe "Pg - -".
- Cosses (type AMP).
- Fils ou câbles solidaires de la bobine.

MISE EN SERVICE

Avant de mettre le circuit sous pression, effectuer un essai électrique. Dans le cas d'une électrovanne, mettre la bobine sous tension plusieurs fois et écouter le "clac" métallique qui signale le fonctionnement de la tête magnétique.

FONCTIONNEMENT

La plupart des électrovannes comportent des bobinages prévus pour mise sous tension permanente. Pour éviter toute brûlure, ne pas toucher la tête magnétique qui, en fonctionnement normal et en permanence sous tension, peut atteindre une température élevée.

BRUIT DE FONCTIONNEMENT

Le bruit de fonctionnement varie selon l'utilisation, le fluide et le type de matériel employé. L'utilisateur ne pourra déterminer avec précision le niveau sonore émis qu'après avoir monté le composant sur l'installation.

ENTRETIEN

L'entretien nécessaire aux produits ASCO/JOUCOMATIC varie avec leurs conditions d'utilisation. Il est souhaitable de procéder à un nettoyage périodique dont l'intervalle varie suivant la nature du fluide, les conditions de fonctionnement et le milieu ambiant. Lors de l'intervention, les composants doivent être examinés pour détecter toute usure excessive. Un ensemble de pièces internes est proposé en pièces de rechange pour procéder à la réparation. En cas de problème lors du montage/entretien ou en cas de doute, veuillez contacter ASCO/JOUCOMATIC ou ses représentants officiels.

Conformément à la directive CEE 89/392/CEE Annexe II B, une Déclaration d'Incorporation peut être fournie sur demande. Veuillez nous indiquer le numéro d'accusé de réception (AR) et les références ou codes des produits concernés.

Ce produit est conforme aux prescriptions les plus importantes de la directive CEM 89/338/CEE et amendements et aux directives basse tension 73/23/CEE et 94/68/CEE. Une déclaration de conformité peut être fournie sur simple demande. Veuillez nous indiquer le numéro d'accusé de réception (AR) ainsi que les numéros de série des produits concernés.



ALLGEMEINE BETRIEBSANLEITUNG

ACHTUNG: Diese Allgemeine Betriebsanleitung gilt in Zusammenhang mit der jeweiligen Betriebsanleitung für die speziellen Produkte.

EINBAU

Die ASCO/JOUCOMATIC-Komponenten dürfen nur innerhalb der auf den Typenschildern angegebenen Daten eingesetzt werden. Veränderungen an den Produkten sind nur nach Rücksprache mit ASCO/JOUCOMATIC zulässig.

Vor dem Einbau der Ventile muß das Rohrleitungssystem drucklos geschaltet und innen gereinigt werden.

Die Einbaulage der Produkte ist generell beliebig. Ausnahme: Die mit einem Pfeil gekennzeichneten Produkte müssen entsprechend der Pfeilrichtung montiert werden.

Die Durchflußrichtung und der Eingang von Ventilen sind gekennzeichnet.

Die Rohranschlüsse sollten entsprechend den Größenangaben auf den Typenschildern mit handelsüblichen Verschraubungen durchgeführt werden. Dabei ist folgendes zu beachten:

- Eine Reduzierung der Anschlüsse kann zu Leistungs- und Funktionsminderungen führen.
- Zum Schutz der Ventile sollten Schmutzfänger oder Filter so dicht wie möglich in den Ventileingängen integriert werden.
- Bei Abdichtung am Gewinde ist darauf zu achten, daß kein Dichtungsmaterial in die Rohrleitung oder das Ventil gelangt.
- Zur Montage darf nur geeignetes Werkzeug verwendet werden.
- Konische Verschraubungen sind sorgfältig anzuziehen. Es ist darauf zu achten, daß beim Anziehen das Gehäuse nicht beschädigt wird.
- Spule und Führungsrohr von Ventilen dürfen nicht als Gegenhalter benutzt werden.
- Die Rohrleitungsanschlüsse sollen fluchten und dürfen keine Spannungen auf das Ventil übertragen.

ELEKTRISCHER ANSCHLUß

Der elektrische Anschluß ist von Fachpersonal entsprechend den geltenden VDE- und CEE-Richtlinien auszuführen. Es ist besonders auf folgendes zu achten:

- Vor Beginn der Arbeiten ist sicherzustellen, daß alle elektrischen Leitungen und Netzteile spannungslos geschaltet sind.
- Alle Anschlußblekmen sind nach Beendigung der Arbeiten vorschriftsmäßig entsprechend den geltenden Regeln anzuziehen.
- Je nach Spannungsbereich muß das Ventil nach den geltenden Regeln einen Schutzleiteranschluß erhalten.

Der Magnetantrieb kann je nach Bauart folgende Anschlüsse haben:

- Anschluß für Geräter Steckdose nach DIN 43650 Form A/ISO 4400 oder 3x DIN 46244 (durch ordnungsgemäße Montage der Geräter Steckdose wird Schutzklasse IP 65 erreicht).
- Anschlüsse innerhalb eines Blechgehäuses mittels Schraubklemmen. Kabeleinführung ins Gehäuse mit PG-Schraubung.
- Offene Spulen mit Flachstecker (AMP-Fahren) oder mit eingegossenen Kabelenden.

INBETRIEBNAHME

Vor Druckbeaufschlagung des Produktes sollte eine elektrische Funktionsprüfung erfolgen:

Bei Ventilen Spannung an der Magnetspule mehrmals ein- und ausschalten. Es muß ein Klicken zu hören sein.

BETRIEB

Die meisten Ventile sind mit Spulen für Dauerbetrieb ausgerüstet. Zur Vermeidung von Personen- und Sachschäden sollte jede Berührung mit dem Ventil vermieden werden, da die Magnetspule bei längerem Betrieb sehr heiß werden kann.

GERÄUSCHEMISSION

Diese hängt sehr stark vom Anwendungsfall, den Betriebsdaten und dem Medium, mit denen das Produkt beaufschlagt wird, ab. Eine Aussage über die Geräuschemission des Produktes muß deshalb von demjenigen getroffen werden, der das Produkt innerhalb einer Maschine in Betrieb nimmt.

WARTUNG

Die Wartung hängt von den Einsatzbedingungen ab. In entsprechenden Zeitabständen muß das Produkt geöffnet und gereinigt werden. Für die Überholung der ASCO/JOUCOMATIC-Produkte können Ersatzzeitsätze geliefert werden. Treten Schwierigkeiten bei Einbau, Betrieb oder Wartung auf, sowie bei Unklarheiten, ist mit ASCO/JOUCOMATIC Rücksprache zu halten.

(ASCO/JOUCOMATIC Produkte sind entsprechend der EG-Richtlinie 89/392/EWG gefertigt.)

Eine separate Herstellererklärung im Sinne der Richtlinie 89/392/EWG Anhang II B ist auf Anfrage erhältlich. Geben Sie bitte für die Produkte die Nummer der Auftragsbestätigung und die Seriennummer an.

Dieses Produkt entspricht den grundlegenden Bestimmungen der EMV-Richtlinie 89/338/EWG, einschl. Nachträge, sowie den Niederspannungsrichtlinien 73/23/EWG u. 93/68/EWG. Bitte geben Sie die Auftragsbestätigungsnummer und die Seriennummern der betreffenden Produkte an.



INSTRUCCIONES GENERALES DE INSTALACION Y MANTENIMIENTO

Nota: Estas Instrucciones Generales de Instalación y Mantenimiento deben considerarse en conjunción con la Hoja de Instrucciones de cada producto.

INSTALACION

Los componentes ASCO/JOUCOMATIC sólo deben utilizarse dentro de las especificaciones técnicas que se especifican en su placa de características o catálogo. Los cambios en el equipo sólo estarán permitidos después de consultar al fabricante o a su representante. Antes de la instalación despresurice el sistema de tuberías y limpie internamente.

El equipo puede utilizarse en cualquier posición si no estuviera indicado lo contrario sobre el mismo mediante una flecha o en el catálogo.

En el cuerpo o en el catálogo se indican el sentido del fluido y la conexión de las válvulas a la tubería.

Las conexiones a la tubería deben corresponder al tamaño indicado en la placa de características la etiqueta o el catálogo y ajustarse adecuadamente.

Precaución:

- La reducción de las conexiones puede causar operaciones incorrectas o defectos de funcionamiento.
- Para la protección del equipo se debe instalar, en la parte de la entrada y tan cerca como sea posible del producto, un filtro adecuado.
- Si se utilizara cinta, pasta, spray u otros lubricantes en el ajuste, se debe evitar que entren partículas en el producto.
- Se debe utilizar las herramientas adecuadas y colocar llaves inglesas lo mas cerca posible del punto de conexión.
- Para evitar daños al equipo, NO FORZAR las conexiones a la tubería.
- No utilizar la válvula o el solenoide como palanca.
- Las conexiones a la tubería no producirán ninguna fuerza, par o tensión sobre el producto.

CONEXION ELECTRICA

Las conexiones eléctricas serán realizadas por personal cualificado y deberán adaptarse a las normas y regulaciones locales.

Precaución:

- Antes de comenzar el trabajo, desconecte el suministro de energía eléctrica y desenergice el circuito eléctrico y los elementos portadores de tensión.
- Todos los terminales eléctricos deben estar apretados adecuadamente según normas antes de su puesta en servicio.
- Según el voltaje, los componentes eléctricos deben disponer de una conexión a tierra y satisfacer las normas y regulaciones locales.

El equipo puede tener uno de los siguientes terminales eléctricos:

- Conexiones desenchufables según ISO 4400 o 3 x DIN-46244 (cuando se instala correctamente esta conexión proporciona una protección IP-65).
- Terminales de tornillo con carcasa metálica con entrada de cable de conexión roscada "PG".
- Conector desenchufable (tipo AMP).
- Salida de cables.

PUESTA EN MARCHA

Se debe efectuar una prueba eléctrica antes de someter a presión el sistema. En el caso de las válvulas solenoides, se debe energizar varias veces la bobina y comprobar que se produce un sonido metálico que indica el funcionamiento del solenoide.

SERVICIO

La mayor parte de las válvulas solenoides se suministran con bobinas para un servicio continuo. Con el fin de evitar la posibilidad de daños personales o materiales no se debe tocar el solenoide, ya que puede haberse calentado en condiciones normales de trabajo.

EMISION DE RUIDOS

La emisión de ruidos depende de la aplicación, medio y naturaleza del equipo utilizado. Una determinación exacta del nivel de ruido sólo puede llevarse a cabo por el usuario que disponga la válvula instalada en su sistema.

MANTENIMIENTO

El mantenimiento de los productos ASCO/JOUCOMATIC depende de las condiciones de servicio. Se recomienda una limpieza periódica, dependiendo de las condiciones del medio y del servicio. Durante el servicio, los componentes deben ser examinados por si hubieran desgastados excesivos. Se dispone de un juego completo de partes internas como recambio o kit de montaje. Si ocurriera un problema durante la instalación/mantenimiento o en caso de duda contactar con ASCO/JOUCOMATIC o representantes autorizados.

Se dispone, por separado y bajo demanda, de una Declaración de Incorporación conforme a la Directiva CEE 89/392/EEC Anexo II B. Rogamos que nos faciliten los códigos y números de aceptación de pedido correspondientes.

Este producto es conforme a las principales prescripciones de la directiva CEM 89/336/CEE y a las enmiendas y directivas baja tensión 73/23/CEE y 94/68/CEE. Si lo desea, podemos facilitarle una Declaración de Conformidad por separado. Rogamos faciliten el número de confirmación de pedido y los números de serie de los respectivos productos.

ASCOMATIC S.A. de C.V.
 Bosques de Duraznos No. 65—1003A
 Fraccionamiento Bosques de las Lomas
 Delegación Miguel Hidalgo
 Mexico, D.F. CP11700
 Tel: (52)—55—5596—7741
 Fax: (52)—55—5596—7719

ASCO Valve Canada
 P.O. Box 160 (Airport Road)
 Brantford, Ontario N3T 5M8
 Tel: (519) 758—2700
 Fax: (519) 758—5540



ISTRUZIONI DI INSTALLAZIONE E DI MANUTENZIONE GENERALE

Nota: Queste Istruzioni devono essere lette in congiunzione con il manuale specifico del prodotto.

INSTALLAZIONE

Le elettrovalvole devono essere utilizzate esclusivamente rispettando le caratteristiche tecniche specificate sulla targhetta. Variazioni sulle valvole o sui piloti sono possibili solo dopo aver consultato il costruttore o i suoi rappresentanti. Prima dell'installazione depressurizzare i tubi e pulire internamente.

Le elettrovalvole possono essere montate in tutte le posizioni. Diversamente, una freccia posta sulla valvola indica che deve essere montata in posizione verticale e dritta.

La direzione del flusso è indicata sul corpo della valvola per mezzo di una freccia oppure con l'etichetta "IN", "1", "A", o "P".

I raccordi devono essere conformi alla misura indicata sulla targhetta apposta.

Attenzione:

- Ridurre i raccordi può causare operazioni sbalziate o malfunzionamento.
- Per proteggere il componente installare, il più vicino possibile al lato ingresso, un filtro adatto al servizio.
- Se si usano nastro, pasta, spray o lubrificanti simili durante il serraggio, evitare che delle particelle entrino nel corpo della valvola.
- Usare un'attrezzatura appropriata e utilizzare le chiavi solo sul corpo della valvola.
- Per evitare danni al corpo della valvola, NON SERRARE ECCESSIVAMENTE i tubi.
- Non usare la valvola o il pilota come una leva.
- I raccordi non devono esercitare pressione, torsione o sollecitazione sull'elettrovalvola.

ALLACCIAMENTO ELETTRICO

L'allacciamento elettrico deve essere effettuato esclusivamente dal personale specializzato e deve essere conforme alle Norme locali.

Attenzione:

- Prima di mettere in funzione togliere l'alimentazione elettrica, disaccettare il circuito elettrico e le parti sotto tensione.
- I morsetti elettrici devono essere correttamente avvitati, secondo le Norme, prima della messa in servizio.
- Le elettrovalvole devono essere provviste di morsetti di terra a seconda della tensione e delle Norme di sicurezza locali.

I piloti possono avere una delle seguenti caratteristiche elettriche:

- Connettore ISO-4400 o 3 x DIN-46244 (se installato correttamente è IP-65).
- Morsetteria racchiusa in custodia metallica. Entrata cavi con pressacavi tipo "PG".
- Bobina con attacchi FASTON (tipo AMP).
- Bobine con fili o cavo.

MESSA IN FUNZIONE

Prima di dare pressione alla valvola, eseguire un test elettrico. Eccitare la bobina diverse volte fino a notare uno scatto metallico che dimostra il funzionamento del pilota.

SERVIZIO

Molte elettrovalvole sono provviste di bobine per funzionamento continuo. Per prevenire la possibilità di danneggiare cose o persone, non toccare il pilota. La custodia della bobina o del pilota può scaldarsi anche in normali condizioni di funzionamento.

EMMISSIONE SUONI

L'emissione di suoni dipende dall'applicazione e dal tipo di elettrovalvola. L'utente può stabilire esattamente il livello del suono solo dopo aver installato la valvola sul suo impianto.

MANUTENZIONE

Generalmente questi componenti non necessitano spesso di manutenzione. Comunque, in alcuni casi è necessario fare attenzione a depositi o ad eccessiva usura. Questi componenti devono essere puliti periodicamente, il tempo che intercorre tra una pulizia e l'altra varia a seconda delle condizioni di funzionamento. Il ciclo di durata dei componenti dipende dalle condizioni di funzionamento. Incaso di usura è disponibile un set completo di parti interne per la revisione. Se si incontrano problemi durante l'installazione e la manutenzione o se si hanno dei dubbi, consultare ASCO/JOUCOMATIC o i suoi rappresentanti.

L'utente può richiedere al costruttore una dichiarazione separata riguardante le Direttive EEC 89/392/EEC e 91/368/EEC (vedere allegato II B) fornendo il numero di serie e il riferimento dell'ordine relativo.

Questo prodotto soddisfa i requisiti essenziali della direttiva CEM 89/336/CEE nonché gli emendamenti e le direttive sulla bassa tensione 73/23/CEE e 94/68/CEE. Una Dichiarazione di Conformità separata può essere ottenuta su richiesta. Si prega di fornire il numero della conferma dell'ordinativo ed i numeri di serie dei relativi prodotti.

ASCOTECH S.A. de C.V.
 Circuito Del Progreso No.27
 Parque Industrial Progreso
 Mexicali, B.C. Mexico
 Tel: (011)—52—686—559—8500
 Fax: (011)—52—686—559—8548



ALGEMENE INSTALLATIE- EN ONDERHOUDSINSTRUKTIES

N.B.: Deze algemene instructies l.a.v. installatie en onderhoud moeten in acht worden genomen tezamen met de specifieke voorschriften van het product.

INSTALLATIE

ASCO/JOUCOMATIC producten mogen uitsluitend toegepast worden binnen de op de naamplaat aangegeven specificaties. Wijzigingen, zowel elektrisch als mechanisch, zijn alleen toegestaan na overleg met de fabrikant of haar vertegenwoordiger. Voor het inbouwen dient het leidingsstelsel drukloos gemaakt te worden en inwendig gereinigd.

De positie van de afsluiter is naar keuze te bepalen, behalve in die gevallen waarbij het tegendeel door pijlen wordt aangegeven. De doorstroomrichting wordt bij afsluiters aangegeven op het afsluiterhuis.

De pijp aansluiting moet overeenkomstig de naamplaatgegevens plaatsvinden.

Hierbij moet men letten op:

- Een reductie van de aansluitingen kan tot prestatie- en funktiestoornissen leiden.
- Ter bescherming van de interne delen wordt een filter in het leidingsnet aanbevolen.
- Bij het gebruik van draadafsluitingsgestak of tape mogen er geen deeltjes in het leidingswerk geraken.
- Men dient uitsluitend geschikt gereedschap voor de montage te gebruiken.
- Bij konische/tapse koppelingen moet met een zodanig koppel worden gewerkt dat het product niet wordt beschadigd.
- Het product, de behuizing of de spoel mag niet als hefboom worden gebruikt.
- De pijp aansluitingen mogen geen krachten of momenten op het product overdragen.

ELEKTRISCHE AANSLUITING

In geval van elektrische aansluiting dient dit door vakkundig personeel te worden uitgevoerd volgens de door de plaatselijke overheid bepaalde richtlijnen.

Men dient in het bijzonder te letten op:

- Voordat men aan het werk begint moeten alle spanningsvoerende delen spanningsloos worden gemaakt.
- Alle aansluitklemmen moeten na het beëindigen van het werk volgens de juiste normen worden aangedraaid.
- Al naar gelang het spanningsbereik, moet het product volgens de geldende normen van een aarding worden voorzien.

Het product kan de volgende aansluitingen hebben:

- Steker aansluiting volgens ISO-4400 of 3x DIN-46244 (bij juiste montage wordt de dichtheidsklasse IP-65 verkregen).
- Aansluiting binnen in het metaal huis d.m.v. schroefaansluiting. De kabeldoover heeft een "PG" aansluiting.
- Spoelen met platte stekker (AMP type).
- Losse of aangegoten kabels

IN GEBRUIK STELLEN

Voordat de druk aangesloten wordt dient een elektrische test te worden uitgevoerd. Ingeval van magneetafsluiters, legt men meerdere malen spanning op de spoel aan waarbij een duidelijk "klikken" hoorbaar moet zijn bij juist functioneren.

GEBRUIK

De meeste magneetafsluiters zijn uitgevoerd met spoelen voor continu gebruik. Omdat persoonlijke of zakelijke schade kan ontstaan bij aanraking dient men dit te vermijden, daar bij langdurige inschakeling de spoel of het spoelhuis heet kan worden.

GELUIDSEMISSIE

Dit hangt sterk af van de toepassing en het gebruikte medium. De bepaling van het geluidsniveau kan pas uitgevoerd worden nadat het ventiel is ingebouwd.

ONDERHOUD

Het onderhoud aan de afsluiters is afhankelijk van de bedrijfsomstandigheden.

In bepaalde gevallen moet men bedacht zijn op media welke sterke vervuiling binnen in het product kunnen veroorzaken. Men dient dan regelmatig inspecties uit te voeren door de afsluiter te openen en te reinigen. Indien ongewone slijtage optreedt dan zijn reserve onderdelen sets beschikbaar om een inwendige revisie uit te voeren.

Ingeval problemen of onduidelijkheden tijdens montage, gebruik of onderhoud optreden dan dient men zich tot ASCO of haar vertegenwoordiger te wenden.

Een aparte fabrikanten verklaring van inbouw, in de zin van EU-richtlijn 89/392/EEG aanhangsel IIB kan door de afnemer na opgave van orderbevestigingsnummer en serienummer verkregen worden.

Dit product voldoet aan de essentiële vereisten van de EMC Richtlijn 89/336/EEG en amendementen, net als aan de richtlijnen 73/23/EEG en 93/68/EEG inzake laagspanning. Een afzonderlijke verklaring van overeenstemming is op verzoek verkrijgbaar. Vermeld a.u.b. het nummer van de opdrachtbevestiging en de serienummers van de betreffende producten.



Innovative Liquid Vaporizing and Gas Mixing Solutions

WARRANTY REGISTRATION

Type of Equipment: _____ Serial Number: _____
 ASDI Sales Order #: _____ Order Date: _____
 Purchased By: _____

To help us give you better service, please fill out this warranty registration form and return it to ASDI to register your purchase and for follow up on the performance of ASDI equipment. We are dedicated to producing a quality product and if a problem occurs, ASDI wants to know about it.

Please help us with a small amount of information about your company and how the equipment will be used. When contacting ASDI, please have the type of equipment and the serial number handy so we can give you accurate information. If you have had any kind of problem with this equipment, or you have any comments, please attach a separate sheet to this form. Keep a copy for your records.

End Customer/Company Name: _____
 Address: _____ Tel: _____
 City: _____ Fax: _____
 State: _____ Zip: _____

Name of individual to contact for follow up information: _____
 Title: _____

Usage - Circle one: Base Load Standby System Peak Shaving
 Other: _____

In what application is the equipment being used? _____
 When was the equipment put in service? _____/_____/_____

Note: If you have more than one piece of ASDI equipment, fill out one warranty sheet and staple the others to it, ASDI will do the rest.

Algas-SDI International, LLC
151 South Michigan Street
Seattle, Washington 98108
USA

Ph.: 1.206.789.5410
Fax.: 1.206.789.5414

www.algas-sdi.com

