

Installation, Operation, Maintenance Disassembly and Assembly Instructions for Models L422 (POL) and L423 (QCC)

June 2000

Form FVC 041 - Rev. 1

KEEP THIS DOCUMENT WITH THE PRODUCT UNTIL IT REACHES THE END USER.

WARNING

Before installation or removal of either hose end valve, the system must be purged completely of all product. Use proper safety equipment at all times. For LP-Gas service follow NFPA / ANSI 58 Standard for the Storage and Handling of Liquefied Petroleum Gases, plus all Local and State Safety Regulations. To insure long term safe operation, the manufacturer recommends that under normal service conditions this product should be inspected at least once every five (5) years and be repaired or replaced as required. To prevent the accidental opening of any valve, never carry or grasp a valve by its handwheel or handle.

CAUTION: Contact with or inhalation of Liquid Anhydrous Ammonia or L-P Gas or their vapors can cause serious injury or death. Dispersment must be in accordance with local regulations.
For the proper handling and storage of Anhydrous Ammonia refer to ANSI Standard K61.1.
For the proper handling and storage of Liquified Petroleum Gas refer to NFPA Pamphlet 58.

TOOLS REQUIRED: Safety Equipment (i.e. gloves, goggles, and clothing), 12" Adjustable Wrench, a 3/16" diameter Drift Pin, a small Ball Peen Hammer, and a 7/16" Open End or Boxed End Wrench.

Removal of Valve for Repair or Replacement

REFER TO FIGURE 1 FOR THE FOLLOWING STEPS:

Step 1: Safety Equipment (i.e. gloves, goggles, and clothing) must be worn before continuing with the next step.

Step 2: Before removing valve, place in FULL OPEN POSITION to insure all pressure is bled from the system.

NOTE: See Warning at top of page.

Disassembly Procedure for Repair

REFER TO FIGURE 1 FOR THE FOLLOWING STEPS:

Step 1: With valve secured in a bench vise, remove the 3/16" diameter Roll Pin (3) which allows the Handle Assembly (1) to be removed from the complete Stem and Disc Holder Assembly (2).

Step 2: Remove Bonnet (5) from Body (13).

NOTE: The Bonnet will move upward approximately 1/16" after the last thread is disengaged from the Body, allowing the Seat Spring (12) to relax to its maximum length. Remove the entire Bonnet Assembly from the Body (13).

Step 3: With the Bonnet Assembly in hand, remove the complete Stem and Disc Holder Assembly (2) and Seat Spring (12) from the Bonnet (5).

Step 4: Remove the Swivel Pad (4) and O-ring (6) from the top of the Bonnet (5). To remove the Seal Sleeve (9), O-ring (8), and Seal Washer (10) from the Bonnet (5), place the 3/16" Drift Pin thru the top hole of the Bonnet (5), and gently push against the top shoulder of the Bonnet Bushing (7).

NOTE: Take care not to let the Drift Pin scratch the Bonnet / O-ring sealing surface as the seal is removed.

CAUTION: NO FURTHER DISASSEMBLY OF THE VALVE IS POSSIBLE. The Inner Barrel of both valves is permanently crimped to the Body (13) at location (A), and cannot be removed. The Fill Valve Seat is permanently crimped to the Inner Barrel Assembly at location (B) and cannot be removed. Any attempt to remove either of these two permanently crimped components could result in damage to the valve, which will cause further operation of the valve to be unsafe for personnel.

Step 5: Fill Valve Seat O-ring (14) may be replaced as often as required.

(OVER)

REFER TO FIGURE 1 FOR THE FOLLOWING STEPS:

- Step 1: Install complete Stem and Disc Holder Assembly (2) thru the top of Body (13) until the Teflon disc rests on the seat inside of Inner Barrel Assembly at location (C). Place Seat Spring (12) over stem to rest on shoulder of stem. Place Seal Washer (10) over stem and push down to rest on top of the Seat Spring (12).
- Step 2: Place O-ring (8) over Seal Sleeve (9) and lubricate O-ring with a good quality grease compatible with the service conditions.
- Step 3: Place O-ring and Seal Sleeve Assembly over Stem with the shoulder side of the Seal Sleeve (9) facing up. Install Bonnet Bushing (7) over Stem.
- Step 4: Install Bonnet Gasket (11) in groove on Body (13). Install Bonnet (5) over Stem and press down firmly to engage threads on Bonnet with internal threads on Body. In order to properly install Bonnet Bushing (7), O-ring (8) and Seal Sleeve (9) into the bore of Bonnet (5), a straight downward push on Bonnet (5) is required for proper alignment. Maintaining a downward push while rotating Bonnet (5) will engage the Bonnet threads in the Body (13). Tighten the Bonnet hard against Bonnet Gasket (11).
- Step 5: Place O-ring (6) into groove on Bonnet (5) and install Swivel Pad (4) over Stem. Lubricate the top surface of Swivel Pad (4) with a small amount of grease.
- Step 6: Place Handle Assembly (1) over Stem, and replace Roll Pin (3).
- Step 7: Open and Close Valve several times, then pressure test Valve for leaks around the Stem and at the Outlet Connections before returning to service.

Installation of New or Repaired Hose End Valves

- Step 1: Apply Teflon tape or sealant on male pipe threads of hose end, and place Valve in Open position.
- Step 2: Install Valve to hose and tighten, taking care to not overtighten.

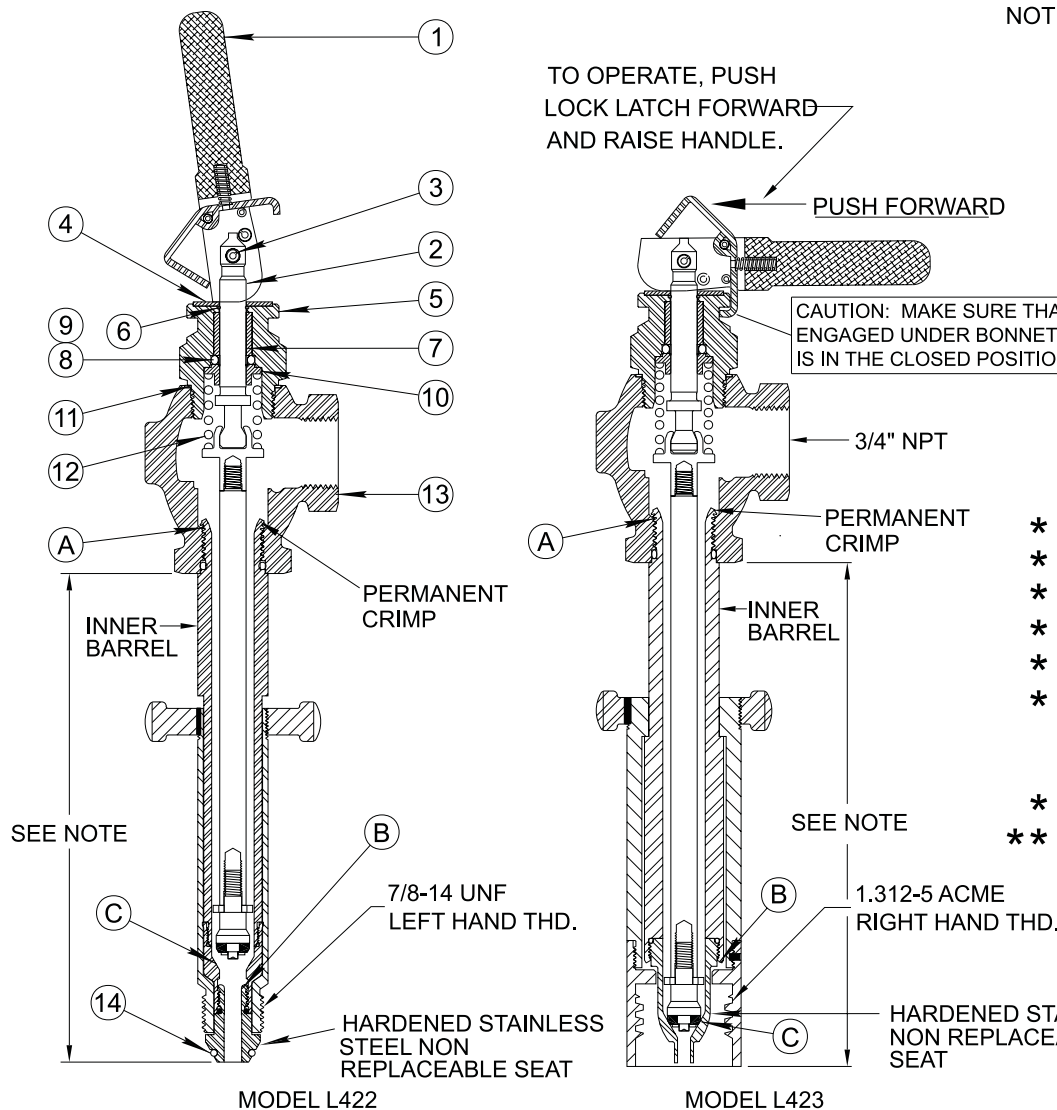

NOTE: THE OUTLET SIDE OF BOTH VALVES IS PERMANENTLY CRIMPED TO THE BODY & CANNOT BE REMOVED. SEE CAUTION AT DISASSEMBLY PROCEDURE.

- ** STEM ASSEMBLY ONLY 422-1300
- ** STEM ASSEMBLY ONLY 423-1300
- * SEAL KIT 422-0022

CAUTION: MAKE SURE THAT HANDLE LOCK LATCH IS ENGAGED UNDER BONNET FLANGE (5) WHEN VALVE IS IN THE CLOSED POSITION.

14	1	FILL VALVE SEAT O-RING
13	1	BODY
12	1	SEAT SPRING
*	11	BONNET GASKET
*	10	SEAL WASHER
*	9	SEAL SLEEVE
*	8	O-RING
*	7	BONNET BUSHING
*	6	O-RING
*	5	BONNET
*	4	SWIVEL PAD
*	3	ROLL PIN
**	2	STEM ASSEMBLY
**	1	HANDLE ASSEMBLY
NO. QTY.		DESCRIPTION
MODEL L422 & L423		