

MANUFACTURED BY PARKER - PGI DIVISION

Service Manual for Flo-Max O-Ring Replacement Kits FM150-0022 & FM150-0024

November 2013 Form FVCFM150-1100-SK - Rev 02

KEEP THIS DOCUMENT WITH THE PRODUCT UNTIL IT REACHES THE END USER.

User Safety Responsibility Statement for All Parker Products

FAILURE OR IMPROPER SELECTION OR IMPROPER USE OF THE PRODUCTS DESCRIBED HEREIN OR RELATED ITEMS CAN CAUSE DEATH, PERSONAL INJURY AND PROPERTY DAMAGE.

- This document and other information from Parker-Hannifin Corporation, its subsidiaries and authorized distributors provide product or system options for further investigation by users having technical expertise.
- The user, through its own analysis and testing, is solely responsible for making the final selection of the system and components and assuring that all performance, endurance, maintenance, safety and warning requirements of the application are met. The user must analyze all aspects of the application, follow applicable industry standards, and follow the information concerning the product in the current product catalog and in any other materials provided from Parker or its subsidiaries or authorized distributors.

To the extent that Parker or its subsidiaries or authorized distributors provide component or system options based upon data or specifications provided by the user, the user is responsible for determining that such data and specifications are suitable and sufficient for all applications and reasonably foreseeable uses of the components or systems.

ITEM	QTY.	PART NO.	DESCRIPTION
1	1	FM150-5012	BALL CARRIER INSTALLATION TOOL (not shown) Included with FM150-0022 ONLY
2	2	P5-197-R0	O-RING (2-220)
3	1	P5-169-R0	O-RING (2-128)
4	1	110-2003	O-RING (2-127)
5	1	P5-304-R0	Quad O-Ring (QR-132)
6	1	P5-086-R0	O-RING (2-030)

Service Kit Number FM150-0022

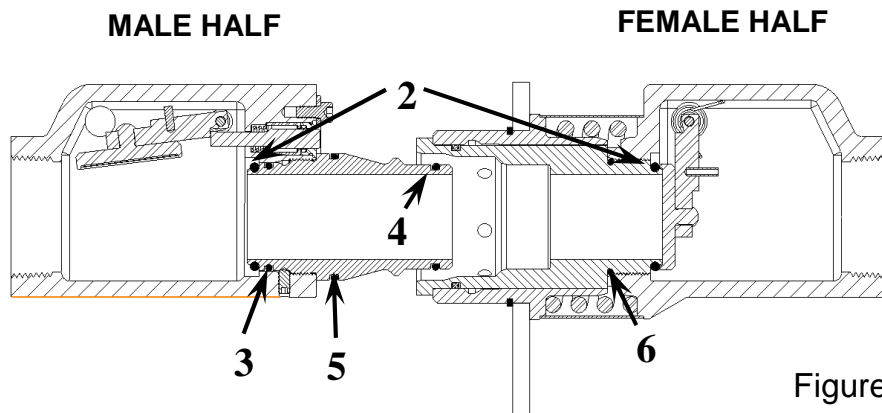

Figure 1

Tools Needed: Large Flat Blade Type Screwdriver, 3/32" Allen Wrench, 5/32" Allen Wrench, Large Adjustable Wrench, Non-Petroleum Based Lubricant

Manual Disconnect Instructions (Refer to FVC078)

See Installation, Operation and Maintenance Manual number FVC078, for warnings and manual disconnect instructions.

While this information is presented in good faith and believed to be accurate, individuals using this literature must exercise their independent judgment in evaluating product selection and determining product appropriateness for their particular purpose, system requirements and certifications. The manufacturer reserves the right to change product designs and specifications without notice.

To Replace O-Rings ②, ③ & ④ on the Male Half (See FIGURE 1 for item numbers.)

1. Secure the Male Half in a bench vise with the Male Plug facing upward. Using a 3/32" Allen wrench, loosen the Set Screw until its end is about 1/8" out from the body.



4. Lubricate the new O-Rings & Quad Ring with a non-petroleum based lubricant and replace them as designated in Figure 1.
5. Lightly lubricate the Male Plug threads with a non-petroleum based

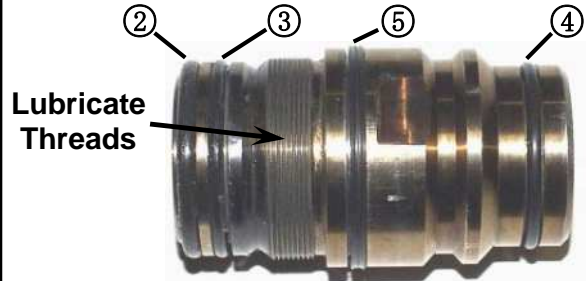

2. Using a 5/32" Allen wrench, remove the Cap Screw and Housing Retainer from the Male Body.

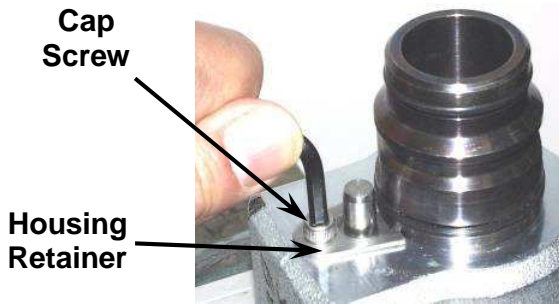

6. Install the Male Plug into the Body, **hand-tight only**.
7. Place the Retainer over the threaded hole, secure with the Cap Screw, and tighten with the 5/32" Allen wrench.



3. Using a large adjustable wrench, turn the Male Plug counter-clockwise and remove it from the Body.

NOTE: Use caution to avoid damage to the Plunger.

**AVOID
DAMAGE
TO THE
PLUNGER**

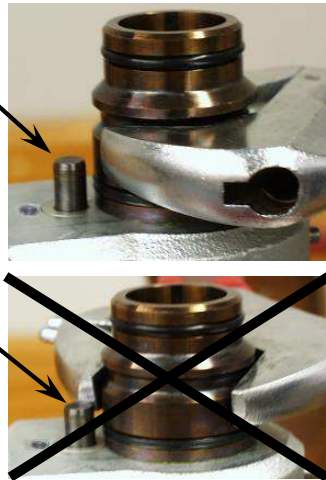

NOTE: If the Check Valve Plunger is to be replaced (Service Kit Number FM125-0023), see the FVC065 for instructions.

8. **Taking care not to damage the Plunger, tighten the Male Plug with a large adjustable wrench.**
9. Tighten the Set Screw on the side of the Body, using the 3/32" Allen wrench.

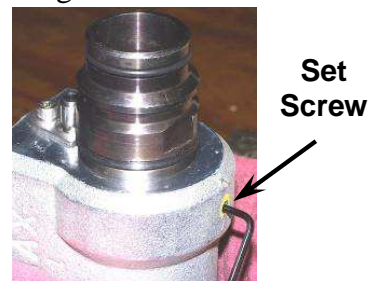

10. The manufacturer suggests that an air test be performed on the entire assembly prior to returning to service.
11. After testing, refer to Installation, Operation and Maintenance Manual number FVC078 for warnings and re-installation instructions.

While this information is presented in good faith and believed to be accurate, Individuals using this literature must exercise their independent judgment in evaluating product selection and determining product appropriateness for their particular purpose, system requirements and certifications. The manufacturer reserves the right to change product designs and specifications without notice.

To Replace O-Rings ② & ⑥ on the Female Half (See FIGURE 1 for item numbers.)

1. Using a screwdriver, remove the Retaining Ring from the bracket to release the Female Half.
2. Secure the Female Half in a bench vise with the Spring Trigger facing upward.



3. Place the Ball Carrier Installation Tool inside the Ball Carrier.

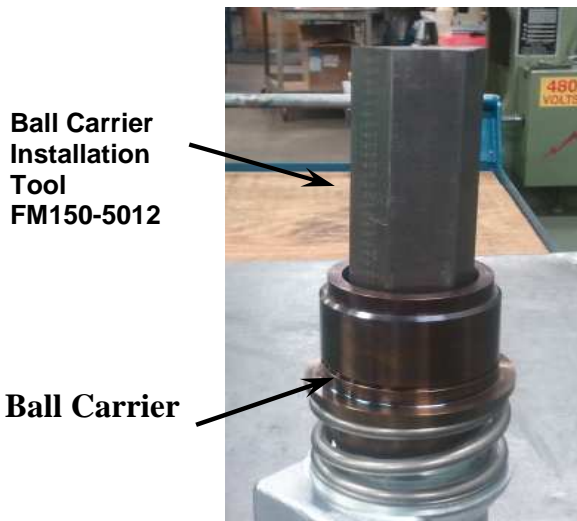

4. Using the large adjustable wrench, turn the Installation Tool counter clock-wise until the Ball Carrier is free from the body.



CAUTION
Do not remove the Ball Carrier from the Spring Trigger. Doing so will release the Latch Balls from the assembly.

NOTE: In the event that the Latch Balls are released from the assembly, hold the Male Plug at the bottom with the Spring Trigger exposing the six ball cavities. Place one Latch Ball into each cavity and slide the Spring Trigger upward, over the balls.

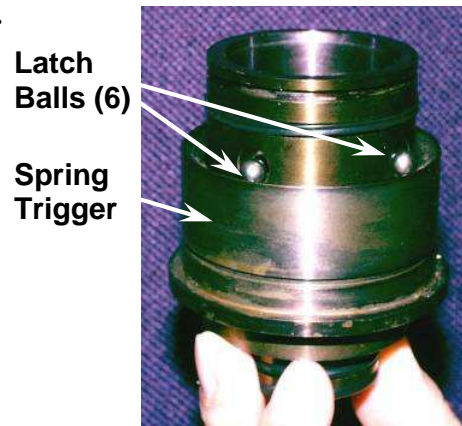

5. Lubricate the new O-Rings with a non-petroleum based lubricant and replace the O-Rings as designated in Figure 1.

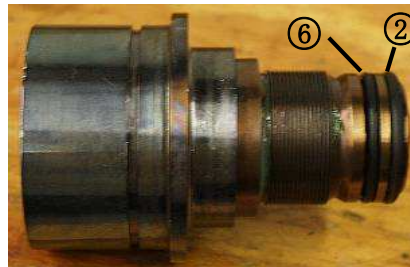

While this information is presented in good faith and believed to be accurate, Individuals using this literature must exercise their independent judgment in evaluating product selection and determining product appropriateness for their particular purpose, system requirements and certifications. The manufacturer reserves the right to change product designs and specifications without notice.

To Replace O-Rings ② & ③ on the Female Half (See FIGURE 1 for item numbers.)

6. To re-assemble the Female Half, place the Spring on top of the Body.



9. Using the Ball Carrier Installation Tool, tighten the Ball Carrier until there it meets the Body.



Tighten the Ball Carrier until it meets the Body.

7. Lightly lubricate the Ball Carrier threads with a non-petroleum based lubricant.

Lubricate Threads Lightly

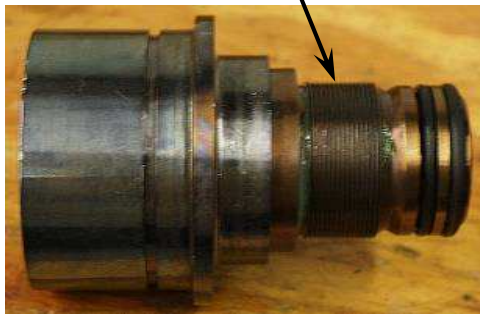

8. Place the Ball Carrier atop the Spring and thread into the Body.



10. The manufacturer suggests that an air test be performed on the entire assembly prior to returning to service.

11. After testing, refer to Installation, Operation and Maintenance Manual number FVC062 for warnings and re-installation instructions.

While this information is presented in good faith and believed to be accurate, Individuals using this literature must exercise their independent judgment in evaluating product selection and determining product appropriateness for their particular purpose, system requirements and certifications. The manufacturer reserves the right to change product designs and specifications without notice.