

MANUFACTURED BY PARKER - PGI DIVISION

Installation, Operation & Maintenance Manual for FM126 EZ Bracket

May 2014

Form FVC085 Rev 03

IMPORTANT: KEEP THIS DOCUMENT WITH THE PRODUCT UNTIL IT REACHES THE END USER.

WARNING!

The EZ Bracket is designed to provide the full freedom of motion required for mounting a safety breakaway coupler. The cam action feature on the bracket handle will assist in manually connecting the breakaway coupler. Either the Squibb-Taylor 1-1/4" Flomax or the Pioneer 1" or 1-1/4" couplers can be used with the EZ Brackets.

WARNING! FAILURE TO READ AND UNDERSTAND THE INSTRUCTIONS CONTAINED IN THIS INSTALLATION, OPERATION AND MAINTENANCE MANUAL CAN LEAD TO PROPERTY DAMAGE AND SERIOUS INJURY OR DEATH.

If you have any questions about anything contained in this manual or desire additional copies, please call Squibb Taylor at 1-800-345-8105 and ask for customer service.

WARNING! PROPER OPERATION OF THIS DEVICE AND YOUR SAFETY DEPENDS ON THE FOLLOWING:

- 1. The mounted coupler must be able to freely swivel approximately 80 degrees to each side AND about 30 degrees up or down.** This must be done so the coupler will be presented with a straight pull by the hose in the event of a situation where the nurse tank comes free of its attachment to the tool bar. If the coupler cannot swivel properly, the hose may pull at an angle which causes the separation force to increase greatly and may bind the coupler preventing separation. **Since pull away events often occur in a turn, the ability of the coupler to swivel as described is critical to proper operation of this device.**
- 2. All piping and valves in the system should be able to withstand a pull force of at least 900 Lbs.**
- 3. The plate on the bracket which contains the slot must be able to move at least 1/3 inch toward the Nurse Tank to allow unlatching of the coupler in the event of a pull away.** The hose and fittings attached to the coupler at the swivel bracket must not catch on anything that would prevent movement of the coupler toward the Nurse Tank during a pull away, otherwise the coupler will not separate.
- 4. Manually connect and disconnect this device before every usage season. Verify ease of movements between the plates and repair or replace as required.**
- 5. WARNING!**
 - **Contact with NH₃ liquid or inhalation of NH₃ vapors can cause serious injury or death.**
 - **Protective clothing, goggles and gloves must be worn at all times.**
 - **Emergency water must be available to flood any NH₃ contact area on the body.**

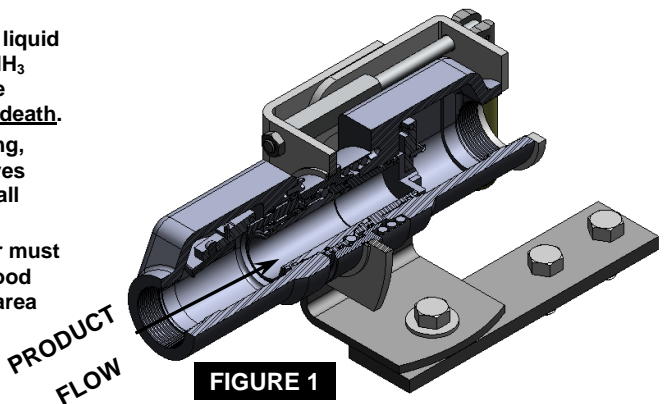

While this information is presented in good faith and believed to be accurate, Individuals using this literature must exercise their independent judgment in evaluating product selection and determining product appropriateness for their particular purpose, system requirements and certifications. The manufacturer reserves the right to change product designs and specifications without notice.

User Safety Responsibility Statement for All Parker Products

FAILURE OR IMPROPER SELECTION OR IMPROPER USE OF THE PRODUCTS DESCRIBED HEREIN OR RELATED ITEMS CAN CAUSE DEATH, PERSONAL INJURY AND PROPERTY DAMAGE.

- This document and other information from Parker-Hannifin Corporation, its subsidiaries and authorized distributors provide product or system options for further investigation by users having technical expertise.
- The user, through its own analysis and testing, is solely responsible for making the final selection of the system and components and assuring that all performance, endurance, maintenance, safety and warning requirements of the application are met. The user must analyze all aspects of the application, follow applicable industry standards, and follow the information concerning the product in the current product catalog and in any other materials provided from Parker or its subsidiaries or authorized distributors.

To the extent that Parker or its subsidiaries or authorized distributors provide component or system options based upon data or specifications provided by the user, the user is responsible for determining that such data and specifications are suitable and sufficient for all applications and reasonably foreseeable uses of the components or systems.

Bracket Installation Instructions

It is mandatory that the EZ Bracket be installed so that it allows the Coupler full freedom to always, and under any condition, align itself for a straight line pull from the nurse tank hose. It is also mandatory that the EZ Bracket assembly be mounted on the tool bar at a location that will ensure the nurse tank hose will not be pinched or restricted from full movement freedom during operation.

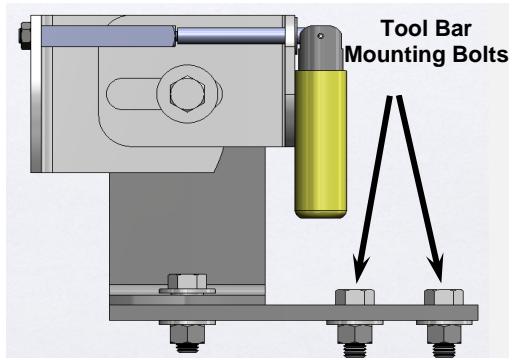

FIGURE 2

WARNING:
Improper constraint of a Coupler outlet hose can cause a **SERIOUSLY UNSAFE CONDITION.**

REFER TO FIGURE 3 — PROPER INSTALLATION

Figure 3 specifies the minimum outlet hose constraint parameters to assure safe rotation of the EZ Bracket.

The outlet hose must have a minimum height of 20 inches and must not be tied down or restricted for at least 4 feet from the EZ Bracket mounting the Coupler.

If these minimum parameters are met, the coupler will have ample slack in the outlet hose to allow the coupler to swivel freely and separate properly in the event of a pull-away.

While this information is presented in good faith and believed to be accurate, Individuals using this literature must exercise their independent judgment in evaluating product selection and determining product appropriateness for their particular purpose, system requirements and certifications. The manufacturer reserves the right to change product designs and specifications without notice.

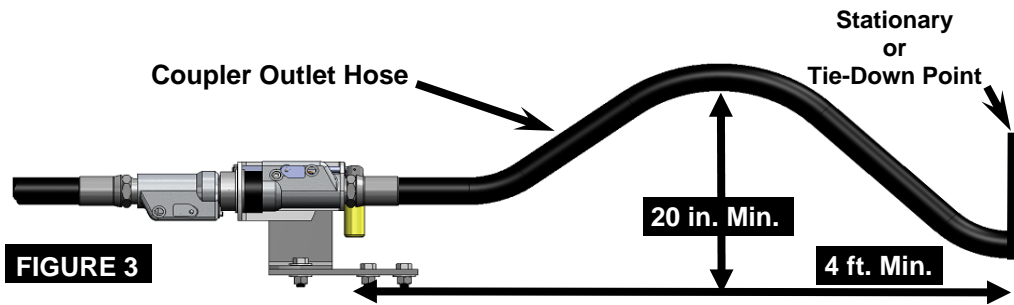

FIGURE 3

WARNING!
THE EZ BRACKET AND INSTALLED COUPLER OUTLET HOSE MUST BE FREE TO SWIVEL AT LEAST 80° TO EACH SIDE AND 30° UP OR DOWN.

Coupler Installation Instructions

Squibb-Taylor Flo-Max Breakaway Coupler is illustrated throughout these instructions. Pioneer 1-1/4" Breakaway Coupler must be installed with a Squibb-Taylor adapter part number A2084 in order to function properly. Pioneer 1" Breakaway Coupler must be installed with a Squibb-Taylor adapter part number A2085 in order to function properly.

1. Open bracket as far as necessary to install female half by rotating handle counter clockwise, figure 4.
2. Screw the handle in until bracket is in contact with the rear of the coupler and install the retaining ring.

Retaining Ring

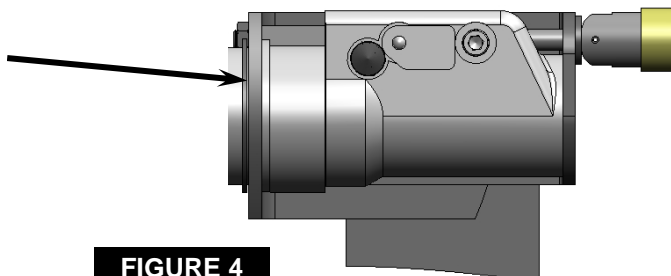

FIGURE 4

3. Actuate cam action by pivoting the bracket handle 80-90 degrees as shown in figure 5. Hold in this position and push the Male half of the Coupler in place, which will allow the Male half to move to its operating position.

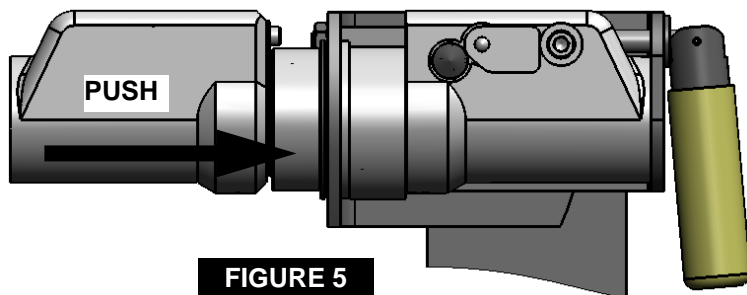

FIGURE 5

While this information is presented in good faith and believed to be accurate, Individuals using this literature must exercise their independent judgment in evaluating product selection and determining product appropriateness for their particular purpose, system requirements and certifications. The manufacturer reserves the right to change product designs and specifications without notice.

Coupler Installation Instructions (cont'd)

- Once the Male half is fully engaged, return the handle to the horizontal position to lock the coupler halves together. Pull the Male Half to make sure the latch is engaged. Rotate the bracket handle 5-6 turns counter clockwise so that it is no longer in contact with bracket and let it hang freely as shown in figure 6. This is the normal operating position and will ensure the coupler will not disengage accidentally.

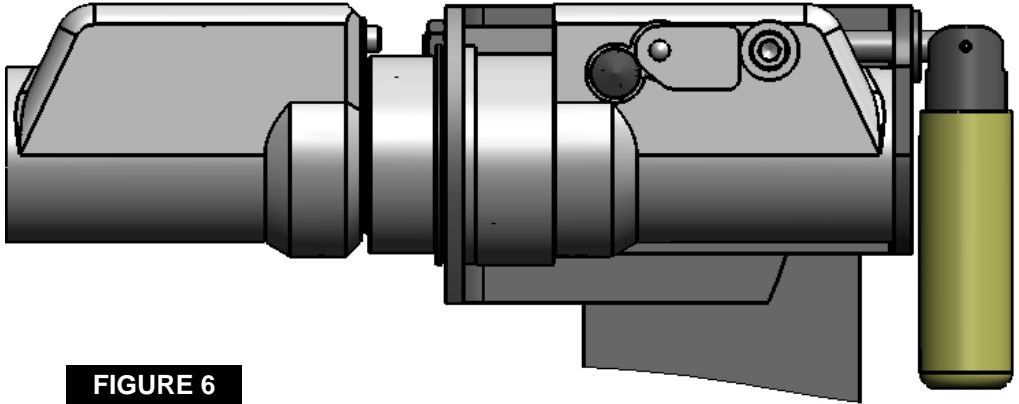

FIGURE 6

- GRASP THE SUPPLY HOSE AND MAKE SURE THE EZ BRACKET CAN FREELY MOVE 80° RIGHT, 80° LEFT, 30° UP AND 30° DOWN, AS A MINIMUM. See FIGURE 3 - PROPER INSTALLATION.**
 - Manually disconnect the coupler as described in step 3+4 on page 6 to verify proper installation.
 - Reconnect the coupler as described in steps 1 through 7 below.
 - Open valves according to applicator manufacturer's instructions when ready to apply NH₃.
-

While this information is presented in good faith and believed to be accurate, Individuals using this literature must exercise their independent judgment in evaluating product selection and determining product appropriateness for their particular purpose, system requirements and certifications. The manufacturer reserves the right to change product designs and specifications without notice.

Coupler Reconnection After Separation

Before attempting to reconnect the Coupler:

1. CLOSE ALL VALVES AND INSPECT ALL HOSES, VALVES AND FITTINGS FOR PROPER CONDITION.

WARNING!

ALL BLEED VALVE MUST BE LEFT OPEN TO PREVENT RESIDUAL LIQUID FROM RE-PRESSURING THE HOSE.

2. **Make sure all Bleed Valves are open**, then insert the Male half into the Female Socket as far as possible using only hand pressure as shown in figure 7.

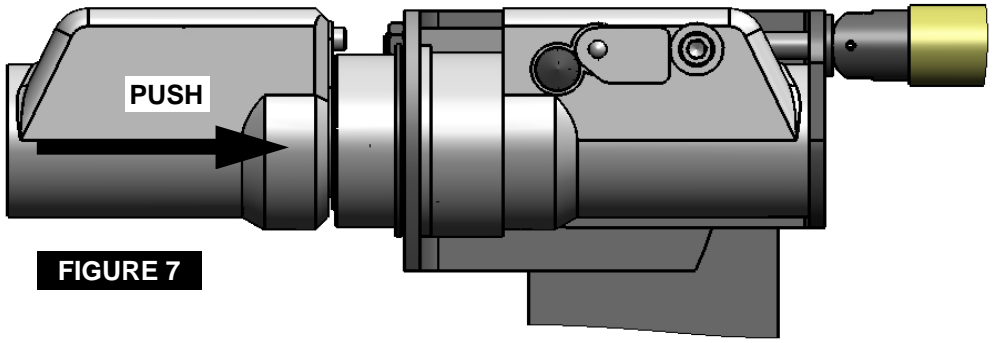

FIGURE 7

3. Actuate cam action by pivoting the bracket handle 80-90 degrees as shown in figure 8. Hold in this position and push the male half in place, which will allow the Male Half to move to its operating position.

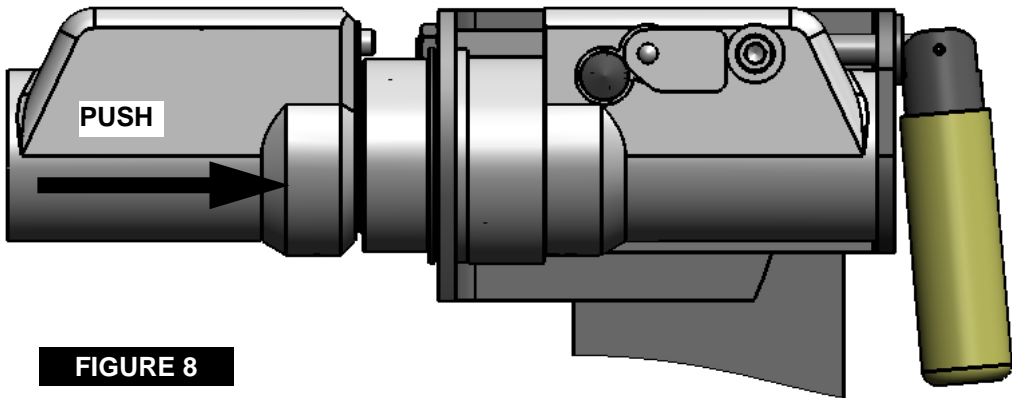

FIGURE 8

While this information is presented in good faith and believed to be accurate, Individuals using this literature must exercise their independent judgment in evaluating product selection and determining product appropriateness for their particular purpose, system requirements and certifications. The manufacturer reserves the right to change product designs and specifications without notice.

Coupler Reconnection After Separation (cont'd.)

4. Once the male half is fully engaged, return the handle to the horizontal position to lock the coupler halves together. Pull the Male Half to make sure the latch is engaged. Rotate the bracket handle 5-6 turns counter clockwise so that it is no longer in contact with bracket and let it hang freely as shown in figure 9. This is the normal operating position and will ensure the coupler will not disengage accidentally.

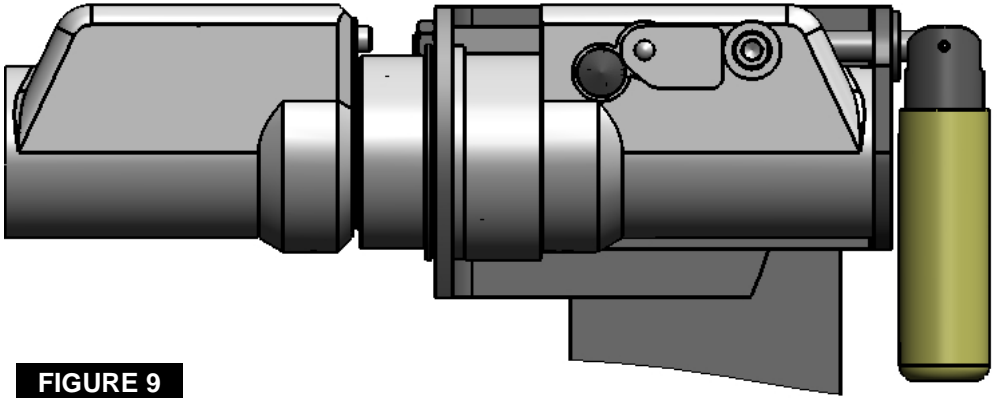

FIGURE 9

5. **GRASP THE SUPPLY HOSE AND MAKE SURE THE MOUNTING BRACKET CAN FREELY MOVE 80° RIGHT, 80° LEFT, 30° UP AND 30° DOWN, AS A MINIMUM. See FIGURE 3 - PROPER INSTALLATION.**

6. CLOSE ALL BLEED VALVES.

7. Open valves according to applicator manufacturer's instructions when ready to apply NH_3 .

While this information is presented in good faith and believed to be accurate, Individuals using this literature must exercise their independent judgment in evaluating product selection and determining product appropriateness for their particular purpose, system requirements and certifications. The manufacturer reserves the right to change product designs and specifications without notice.

Manual Disconnect Coupler Instructions (cont'd.)

1. CLOSE THE NURSE TANK WITHDRAWAL VALVE.
2. OPEN ALL BLEED VALVES ON THE MALE HALF TO RELIEVE PRESSURE IN THE NURSE TANK HOSE. LEAVE THE BLEED VALVE OPEN.
NOTE: Pressure may be trapped in the Female Half, but the Coupler may still be reconnected.

WARNING!
THE BLEED VALVE MUST BE LEFT OPEN TO PREVENT RESIDUAL LIQUID FROM RE-PRESSURING THE HOSE.

3. Screw the handle in until it makes contact with the rear of the coupler, as shown in figure 10.

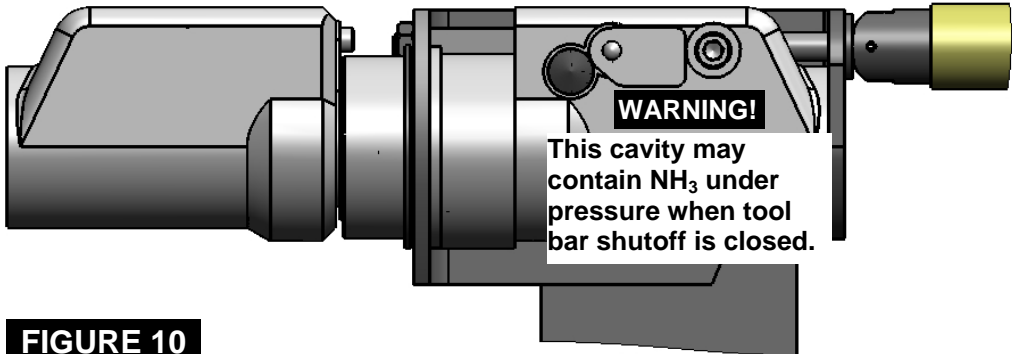

FIGURE 10

4. Actuate cam action by pivoting the bracket handle 80-90 degrees, as shown in figure 11. Hold in this position and remove the Male half by pulling on it to separate the two halves.

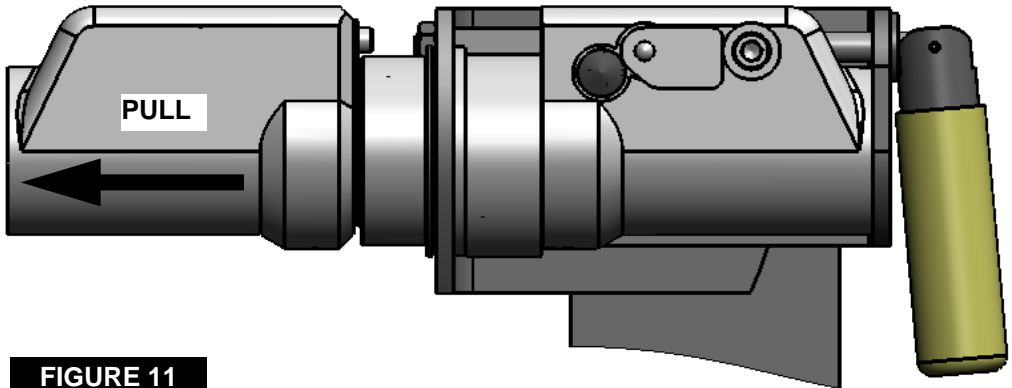
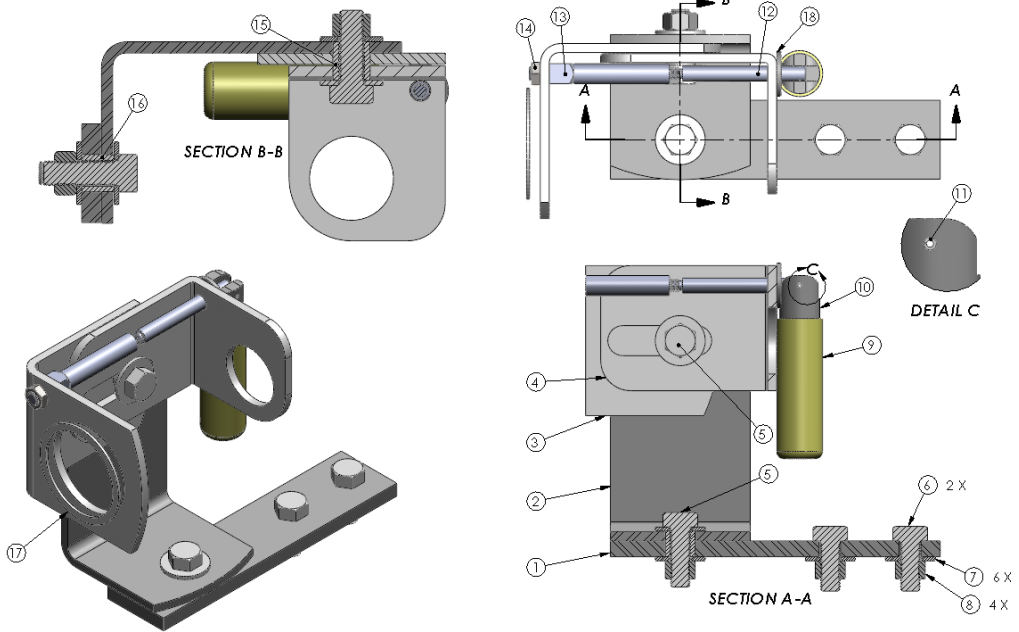

FIGURE 11

5. Once the male half is removed, return the handle to the horizontal position and screw out the bracket handle 5-6 turns so that it is no longer in contact with the bracket and able to hang freely.

While this information is presented in good faith and believed to be accurate, Individuals using this literature must exercise their independent judgment in evaluating product selection and determining product appropriateness for their particular purpose, system requirements and certifications. The manufacturer reserves the right to change product designs and specifications without notice.



NO.	PART NO.	DESCRIPTION	QTY.
1	RB1-2008	TOOLBAR MOUNTING BRACKET	1
2	RB1-2006	HORIZONTAL ROTATION BRACKET	1
3	FM125-2007	ADAPTER BRACKET	1
4	FM126-2014	FM126 SIDE PLATE	1
5	P6-212-10	1/2"-13 X 1-1/2" HEX CAP SCREW	2
6	P6-211-10	1/2"-13 X 1-1/4" HEX CAP SCREW	2
7	P6-214-10	1/2" WASHER	6
8	P6-213-10	1/2"-13 HEX NUT PREVAILING TORQUE	4
9	FM150-2022	FM150 SWIVEL BRACKET HANDLE SLEEVE	1
10	FM150-5016	LEVER CAM NON-LOCK	1
11	P4-025-R0	1/8" DIA X 1" LONG ROLL PIN	1
12	FM126-5015	SHORT ROD	1
13	FM126-5017	1/2" SQUARE STANDOFF	1
14	312-2015	3/8-24 HEX JAM NUT	1
15	FM150-5013	BUSHING	1
16	RB1-5012	BUSHING	1
17	RBI-2003	SPIRAL RETAINING RING RSN-250	1
18	FM126-5010	FLAT WASHER	1
19	FVC085	IOM	1

While this information is presented in good faith and believed to be accurate, Individuals using this literature must exercise their independent judgment in evaluating product selection and determining product appropriateness for their particular purpose, system requirements and certifications. The manufacturer reserves the right to change product designs and specifications without notice.