

Installation, Operation & Maintenance Manual

Stationary Coro-Vane® Pumps for LPG and NH₃

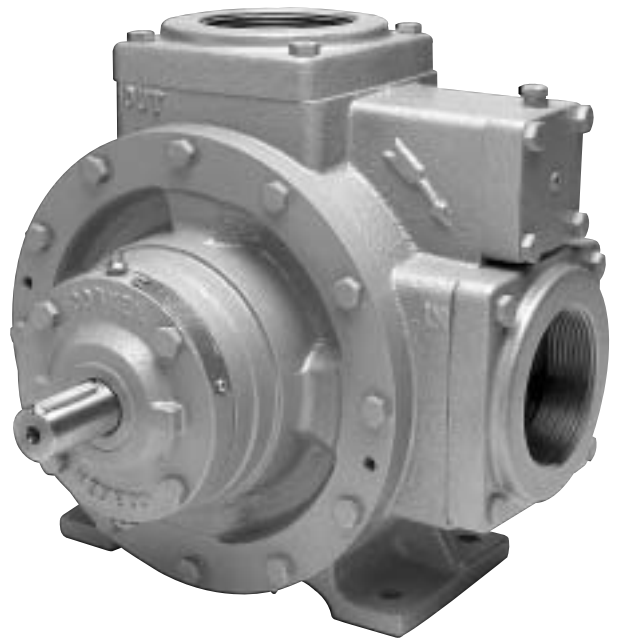

C51 Model



1021 Model

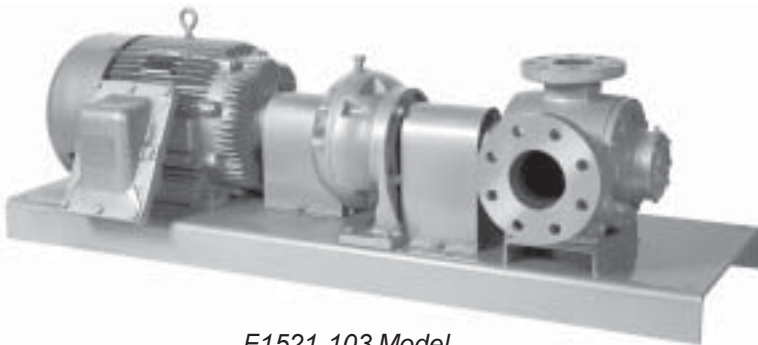

F1521-103 Model

Warning: (1) Periodic inspection and maintenance of Corken products is essential. (2) Inspection, maintenance and installation of Corken products must be made only by experienced, trained and qualified personnel. (3) Maintenance, use and installation of Corken products must comply with Corken instructions, applicable laws and safety standards (such as NFPA Pamphlet 58 for LP-Gas and ANSI K61.1-1972 for Anhydrous Ammonia). (4) Transfer of toxic, dangerous, flammable or explosive substances using Corken products is at user's risk and equipment should be operated only by qualified personnel according to applicable laws and safety standards.

Solutions beyond products...

CORKEN
IBEX

Warning

Install, use and maintain this equipment according to Corken's instructions and all applicable federal, state, local laws and codes. Periodic inspection and maintenance is essential.

Corken One Year Limited Warranty

Corken, Inc. warrants that its products will be free from defects in material and workmanship for a period of 12 months following date of purchase from Corken. Corken products which fail within the warranty period due to defects in material or workmanship will be repaired or replaced at Corken's option, when returned, freight prepaid to Corken, Inc., 3805 N.W. 36th Street, Oklahoma City, Oklahoma 73112.

Parts subject to wear or abuse, such as mechanical seals, vanes, piston rings, packing and other parts showing signs of abuse are not covered by this limited warranty. Also, equipment, parts and accessories not manufactured by Corken but furnished with Corken products are not covered by this limited warranty and purchaser must look to the original manufacturer's warranty, if any. This limited warranty is void if the Corken product has been altered or repaired without the consent of Corken.

All implied warranties, including any implied warranty of merchantability or fitness for a particular purpose, are expressly negated to the extent permitted by law and shall in no event extend beyond the expressed warranty period.

Corken disclaims any liability for consequential damages due to breach of any written or implied warranty on Corken products. Transfer of toxic, dangerous, flammable or explosive substances using Corken products is at the user's risk. Such substances should be handled by experienced, trained personnel in compliance with governmental and industrial safety standards.

Important notes relating to the European Union (EU) Machinery Directive

Pumps delivered without electric motors are not considered as machines in the EU Machinery Directive. These pumps will be delivered with a Declaration of Incorporation. The fabricator of the machinery must assure and declare full compliance with this Directive before the machine in which the pump will be incorporated, or of which it is a part, is put into service.

Contacting the Factory

Before you contact the factory, note the model number and serial number of your pump. The serial number directs us to a file containing all information on material specifications and test data applying to your specific pump. When ordering parts, the Corken service manual or Installation, Operations and Maintenance (IOM) manual should be consulted for the proper part numbers. ALWAYS INCLUDE THE MODEL NUMBER AND SERIAL NUMBER WHEN ORDERING PARTS.

The model and serial numbers are shown on the nameplate of the unit. Record this information for future reference.

Model no. _____

Serial no. _____

Date purchased _____

Date installed _____

Purchased from _____

Installed by _____

Table of Contents

Principles of Your Coro-Vane® Pump	4
Exclusive Features of Your Coro-Vane® Pump	4
Installation of Your Coro-Vane® Pump	4
Inlet Piping	5
Outlet Piping	5
By-Pass System	5
Vapor Equalizing System	5
Driver Installation	5
Operation of Your Coro-Vane® Pump	6
Piping Diagram	7
Maintenance of Your Coro-Vane® Pump System	8
Pump Maintenance Schedule	8
Preventative Maintenance Program	9
Seal Replacement Instructions	10
Parts Details For A Stationary Coro-Vane® Seal Assembly	13 and 14
Repair Kits	15
Parts Details For All Stationary Coro-Vane® Models	16–22
Appendix A	
Model Number and Identification Code	23 and 24
Appendix B	
Operating, Material and Flange Specifications	25 and 26
Appendix C	
Performance Curves	27–30
Appendix D	
Outline Dimensions	31–36
Appendix E	
V-Belt Selection Guide	37
Appendix F	
Troubleshooting Guide	38
Appendix G	
Storage of Your Coro-Vane® Stationary Pump	39

Principles of Your Coro-Vane® Pump

The Corken Coro-Vane® pumps are a special type of rotary positive displacement pump, known as a sliding vane pump.

The sliding vane pump has many of the positive displacement advantages of the gear pump, plus the ability to compensate for wear, and operate at a lower noise level.

The sliding vane pump consists of a rotor turning in a cam (liner) machined eccentrically in relation to the rotor; thereby displacing the liquid trapped between the rotor, cam and vanes. The Corken Coro-Vane® pumps are made with vanes produced from advanced polymers which exhibit extremely low coefficients of friction. The vanes are self-adjusting for wear which gives the pump long life.

Exclusive Features of Your Coro-Vane® Pump

The pumping of volatile liquids is one of the most difficult of all pumping jobs, so more attention must be given to the design and manufacture of the pump and to its installation and operation.

In addition to being especially suited for handling volatile liquids, your Coro-Vane® pump has a number of features to help make it more easily operated and maintained.

The Coro-Vane® pump is manufactured in six models: the Models C51 and F51 small stationary and the Models 521, 1021, F1021 and F1521 stationary pumps. The Models F1021 and F1521 have ANSI flanged connections. All six models have been registered and listed by the UNDERWRITERS' LABORATORIES, INC. for use in the handling of LP-Gas and Ammonia.

The CASE AND HEADS are made of ductile iron for extra strength and toughness.

The VANES are manufactured of advanced polymers to provide excellent life and quiet operation. After long service, the vanes are simply and inexpensively replaced.

Both the CAM and the SIDEPLATES are easily replaced should the need arise.

The MECHANICAL SEAL is designed for longer life under greater loads and may be inspected or replaced without disturbing the piping of the pump. No special tools are needed.

BEARINGS are heavy-duty roller type for long bearing life.

PRESSURE GAUGE connections, 1/4" pipe thread, are provided.

The PUMP NOZZLES on Models 521 and 1021 are equipped with flanges to simplify piping. It is not necessary to provide unions in the piping system near the pump because the flanges serve this purpose.

The RELIEF VALVE is built-in as part of the pump on models 521 and 1021 and is adjustable under pressure.

NOTE: EVEN WITH THIS INTERNAL SAFETY VALVE, AN EXTERNAL BY-PASS VALVE MUST BE INSTALLED.

Installation of Your Corken Coro-Vane® Pump

The installation of the Coro-Vane® pump is simple. However, in order for the pump to deliver optimum performance, the principles discussed in this book should be followed. The piping details are furnished to illustrate methods proved by hundreds of installations. Your own needs may require slight variations, but every effort should be made to follow the recommendations identified in this manual.

No pump can discharge more liquid than it receives, so the pump location and the inlet piping must be given careful attention. If the inlet piping is inadequate to supply the demand of the pump, you may expect trouble. The inlet sizes shown in figure 2, page 7, are the smallest size piping you can use with success.

For the transfer of flammable liquids like LPG, the pump must be installed according to the applicable local safety and health regulations. The installer and/or the user must take into account the following:

- The pump must be located as near the storage tank as possible. The complete inlet line, including the vertical line from the tank must not exceed twelve feet (3.7 m) in length.
- The bottom of the tank must be no less than two feet (0.6 m) above the pump inlet nozzle, with four feet (1.2m) considered standard.
- The foundation for the pump is important. The foundation must be firm, level and preferably made of concrete. The suggestions in figure 1 should be observed.

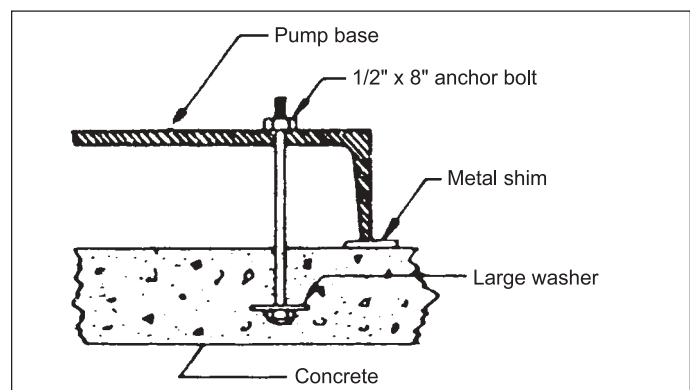

Figure 1

- Potential risk due to local conditions regarding the installation and operation (e.g. poor ventilation and additional risks due to other elements in the vicinity, etc.).
- Qualification of the personnel.
- Type of liquid being transferred.

- Specific safety measures to be applied (e.g. gas detection, automatic shut-off valves, personal protective equipment, etc.).

The following table shows the weight of the bare pump for each model. For handling a bare pump, lifting slings should be used. Web slings are preferred over metal slings to minimize damage to the paint. See Appendix D for outline dimensions.

Model	Shipping Weight	
	lb	kg
C51	50	22.7
F51	25	11.3
521	132	59.9
1021	200	90.7
F1021	200	90.7
F1521	235	106.6

The Inlet Piping Should Include the Following:

1. The tank excess flow valve (EFV) should have a flow rate of 1-1/2 to 2 times the capacity of the pump. Do not use an EFV without knowing its flow capacity.
2. The tank shut-off valve must be a free-flow type and not a standard globe valve.
3. A strainer of the “Y” type, with 30 to 40 mesh screen, must be on the inlet line of the pump. (Mesh size indicates the number of openings per lineal inch).
4. Use a flexible connection in the pump inlet and outlet piping to compensate for piping strains.
5. Use an eccentric swage at the pump inlet nozzle to change the line size (flat side up).
6. Make the inlet line level or slope it downward to the pump.
7. The minimum inlet piping sizes shown in figure 2, page 7, must be observed.

The Outlet Piping Should Include the Following:

1. A pressure gauge should be installed in the pump outlet or near it. A pressure gauge is necessary to determine the efficiency of your pumping system.
2. A hydrostatic relief valve is required by most state laws and for your own safety.
3. If the outlet piping exceeds 50 feet (15.2 m) in length a check valve should be installed near the pump outlet.
4. The minimum outlet piping sizes shown in figure 2, page 7 should be observed.

The By-Pass System Must Include the Following:

1. A pump by-pass system must be installed. If the pump discharge is shut off before the driver is stopped,

dangerously high pressures can develop, unless a by-pass valve is installed to permit the pump to discharge back to the supply tank, at a predetermined pressure.

2. The pump may have an internal relief valve, but it is intended as a safety relief valve device and not an operational by-pass.
3. Always install an external by-pass relief valve (such as the Corken B177) in the pump discharge line. The by-pass valve may discharge into the tank at any convenient opening, either liquid or vapor; however, it should not connect into the pump inlet piping system.

Pump Model	Max Differential Pressure
521, 1021, F1021	125 psi (8.8 kg/cm ²)
F1521	100 psi (7.0 kg/cm ²)

A Vapor Equalizing System Should be Included:

To obtain maximum performance from your Coro-Vane® pump, a vapor equalizing system should be installed. This system is simply a pipe connecting the vapor sections of the tank being unloaded and the tank being filled. This equalizing line allows vapor to move freely between the two tanks (in either direction) and assures that both tanks remain at the same pressure.

As liquid is withdrawn from a tank, it must be replaced by an equal amount of vapor or the pressure in the tank will drop. If an equalizing line is not present, this vapor is formed by “boiling” of the liquid and a reduction of the tank’s pressure. Meanwhile, the tank being filled experiences a pressure increase as the rising fluid levels compresses the vapor space above it. A vapor equalizing line will eliminate both of these problems and will reduce pumping time, differential pressure, noise and wear on the entire system. Slow transfer rates will minimize these effects, and reduce the need for a vapor equalizing line. However, today’s high transfer rates require that a vapor equalizing line be installed.

Another way to consider this principle is to remember that it takes two holes in an oil can for oil to be poured smoothly from the can; one for the oil to exit and the other for the air to enter. The piping and hose sizes shown in figure 2, page 7 should be considered minimum.

Driver Installation

Pump Model	Maximum Speed
521, 1021, F1021	950 RPM
F1521	860 RPM

The wiring of your electric motor is extremely important and must be done by a competent electrical contractor. The following wire sizing chart indicates the minimum standards for wire sizes.

Hp	Motor			Recommended wire size, AWG ¹		
	Motor phase	Volts	Approximate full load amperes	Length of run (ft)		
				0-100	to 200	to 300
3	1	115	34.0	6	4	2
		220	17.0	12	8	8
	3	230	9.6	12	12	12
		460	4.8	12	12	12
5	1	115	56.0	4	1	1/0
		230	28.0	10	6	4
	3	230	15.2	12	12	10
		460	7.6	12	12	12
7-1/2	1	230	40.0	8	6	4
	3	230	22.0	10	10	8
		450	11.0	12	12	12
10	3	230	28.0	8	8	8
		460	14.0	12	12	12
15	3	230	42.0	6	6	6
		460	21.0	10	10	10
		230	54.0	4	4	4
20	3	460	27.0	8	8	8
		230	68.0	2	2	2
25	3	460	34.0	6	6	6
		230	80.0	1	1	1
30	3	460	40.0	6	6	6
		230	100.0	2/0	2/0	2/0
40	3	460	52.0	4	4	4
		230	130.0	3/0	3/0	3/0
50	3	460	65.0	2	2	2

¹Based upon 3% voltage loss copper wire type TW. Single phase motor calculations are based on two times distance.

Improper motor wiring will cause expensive motor difficulties from low voltage. If you suspect you have low voltage, call your power company. Connecting your motor for the voltage you have available is important too. The motors furnished with the stationary pumps are usually dual voltage, so you must be sure of the voltage your power company is supplying you. Your motor will be completely ruined if it is connected to the wrong voltage.

A humid climate can cause problems, particularly in explosion proof motor applications. The normal breathing of the motor, and alternating between being warm when running and cool when stopped, often will cause moist air to be drawn into the motor housing. This moist air will condense, and may eventually add enough free water to the inside of the motor to cause it to fail. To prevent this, make a practice of running the motor and pump at least once a week on a bright, dry day for an hour or so (pumping through the by-pass system). In this period the motor will heat up and vaporize the condensed moisture, and drive it out of the motor. No motor manufacturer will guarantee an explosion-proof or totally enclosed motor against damage from moisture.

Engine drivers pose a special consideration. The manufacturer's instructions must be followed. When the stationary pump is equipped with an engine from the factory, the engine speed should normally not exceed 1,800 RPM. Excessive engine speed will overload the engine and cause early failure. The engine loses 3% of its power for every 1,000 feet (305 m) above sea level, so if your installation is at a higher altitude than normal, consult the factory.

Operation of Your Coro-Vane® Pump

Performance curves and charts are provided in Appendix C.

The following steps should be performed for the initial pumping operation:

1. Verify the strainer screen is clean.
2. Rotate the pump by hand.
3. Check V-belt drive or direct drive coupling alignment. Misalignment will cause accelerated wear of the drive system, motor bearings and pump.
4. Check motor for proper wiring.
5. Review complete system to make certain the function of every valve and piece of equipment is clearly understood. Everyone operating this system must be properly trained in normal operating procedures and emergency procedures in event of a malfunction.
6. Close all hose valves.
7. Slowly open the storage tank bottom shut-off valve (suction line to the pump). Immediately check the system for leaks.
8. Open any shut-off valves between the by-pass valve and the storage tank.
9. Make a note of all pressure gauge readings, especially the pressure gauge located at the discharge of the pump. Start the pump and circulate the liquid through the by-pass system back to the storage tank.
10. Verify the proper pump rotation direction. There is an arrow cast in the pump case.
11. An ammeter may be used by adjusting the by-pass valve until the ammeter indicates the full load motor amperage rating shown on the motor nameplate or maximum rated differential, whichever comes first. Permit the pump to circulate liquid for half an hour or more. If the motor overload protection device stops the motor in this period the by-pass valve setting is too high and should be readjusted until the motor will run for half an hour. After a satisfactory setting is achieved, "seal" the valve adjusting stem to prevent tampering with the adjustment. See IH102 for more details on the use of the Corken by-pass valves.
12. If your pump has an internal relief valve, it must be set higher than the external by-pass setting. The internal relief valve may be adjusted while the pump is under pressure by removing the flush seal plug. Turning the adjusting screw clockwise will decrease the internal relief valve setting. Replace the flush seal plug after adjustment.
13. After initial operation, re-check the strainer screen.

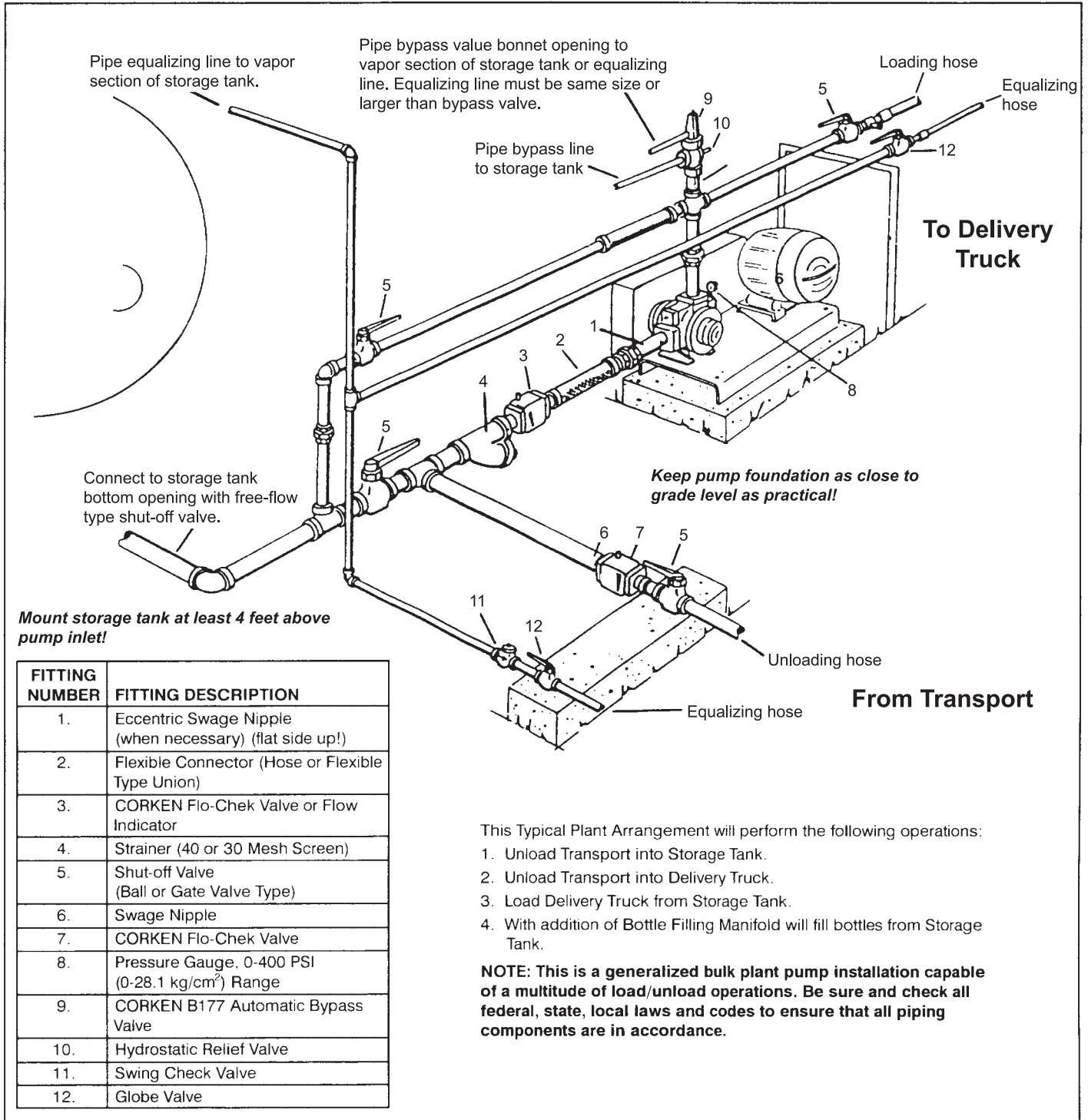

Figure 2

Maintenance of Your Coro-Vane® Pump System

All repairs to the pump must be performed by qualified personnel in a safe manner, utilizing tools and/or equipment that are free of hazards, and follows the applicable safety codes of practice set by the local authorities having jurisdiction. Make sure the system pressure has been relieved before attempting any repair to the pump.

Your Corken pump requires regular maintenance and care like all mechanical equipment. A neglected or improperly repaired pump will result in premature failure and cause unsafe conditions.

To promote product longevity and safety, maintenance must be performed by properly trained technicians. Make sure all safety systems are in place and the system pressure has been relieved before attempting **ANY** maintenance.

Make sure the transfer hoses are not "kinked" which can cause excessive pump discharge pressure. Always make sure your hoses are not out of date.

There are two lubrication points in which to grease the pump bearings; one zerk per bearing cap located at opposite ends of the pump. Four grease relief and seal ventilation fittings have been provided, two at each end of the pump, to prevent overgreasing the bearings. Overgreasing can cause seal failure if grease passageways are blocked in some way. Clean each fitting before lubricating the bearings. This practice helps to prevent foreign-material contamination of the bearings and accidental over-pressurization of the mechanical seals. Use only ball bearing grease (MIL-G-10924C) with a temperature rating of -50°F.

Normal wear parts are the mechanical shaft seals, bearings, vanes and sideplates. All of these parts plus O-rings and grease seals are offered in the Corken "repair kit" listed in this manual directly after the Seal Replacement Instruction on pages 10–15. Use only genuine Corken replacement parts when repairing your Corken pump.

When it becomes necessary to repair your pump or remove it from the system, you must be absolutely certain that all propane, anhydrous ammonia or whatever product being pumped is bled from the pump and connecting piping. Once all the product has safely been bled from the pump and connecting piping, make certain no pressure is left in the system.

SPECIAL CARE MUST BE TAKEN DURING THE BLEED DOWN PROCESS TO AVOID DANGER TO PERSONNEL AND PROPERTY IN THE AREA. Bleeding a system too fast is a common mistake and may leave "refrigerated" liquid in the pump and piping even though the pressure gauge shows no pressure. As the "refrigerated" liquid begins to

warm, more gas will escape causing a dangerous condition. Take your time in bleeding your system and make proper provisions to vent or capture the gas in accordance with local regulations. **ONLY A PROPERLY TRAINED INDIVIDUAL SHOULD BE ALLOWED TO BLEED A PUMPING SYSTEM.**

Pump Maintenance Schedule

	Daily	Monthly	3 Months
Lubricate bearings			X ¹
Inspect drive coupling			X
Clean inlet strainer		X	
Check for leaks	X		
Inspect hose and fittings	X		

¹Continuous duty applications may require monthly lubrication.

Figure 3

If your pump's use is seasonal, then special care must be taken during the off season to protect your pump from corrosion. If it is feasible and safe to keep the pump pressurized with product during the off season, this will prevent the entrance of any moisture or air. This system should be checked periodically to make certain all of the gas has not bled out.

If your Coro-Vane® pump is to be removed from service for some time, the pump must be protected., as propane, butane and anhydrous ammonia all leave the metal "bare" and open to corrosion. Piping and tanks not in service should also be protected, as the rust that forms can destroy the pump's seals almost immediately after start-up. To prevent these problems, complete the following:

1. Fill or thoroughly flush the pump with a light rust-inhibiting oil. If the pump is flushed with oil, placing some desiccant packets inside the pump will provide added protection.
2. Plug all pump openings.
3. Store in a dry location.
4. Before placing the pump back into service, drain the oil and remove any desiccant packets.
5. Refer to page 6 of this manual for start up operation instructions.

Preventative Maintenance Program for Corken Coro-Vane® Pumps

Purpose

By following an effective preventive maintenance program, unscheduled downtime can be eliminated. This program should be used by the Operation Manager to get a maximum utilization of manpower and equipment as well as to prevent possible unsafe situations and/or production delays due to equipment breakdown.

Scope

The Preventive Maintenance chart in figure 3, page 8, includes the items to be regularly checked and inspected with a recommended time schedule. These are basic maintenance recommendations, and each company should develop their own comprehensive preventive maintenance program schedule, tailor-made to their individual operational procedures and requirements.

Maintenance must only be performed by a properly trained and qualified individual following all the applicable safety procedures.

Procedures

Every procedure herein recommended must be performed in a safe manner (utilizing tools and/or equipment which are free of hazards) and following the safety codes of practice set by the authorities having jurisdiction. These are general guidelines and are not intended to cover all the safety aspects that must be considered and followed while performing these procedures.

1. Visual Inspection:

This includes checking for leaks, corroded areas, condition of hoses, piping and fittings, and any unsafe condition which may hinder the safety of the personnel and/or the facility.

2. Clean Inlet Strainer Screen:

A clogged strainer screen will create too much flow restriction and vapor will be formed causing the pump to cavitate. This reduces the pump's capacity and accelerates the wear of the internal parts.

3. Inspect Drive Coupling and Driveline:

Check the coupling alignment and the condition of the union for cuts, broken sections and wear.

4. Lubricate Pump Bearings:

Use only ball bearing grease, applied with a manual lubrication pump or gun. Always clean the grease openings thoroughly before greasing.

5. Lubricate Motor Bearing:

Follow the recommendations of the electric motor

manufacturer for the type of grease to use and the lubrication frequency.

6. Performance Test:

a. While transferring liquid with the pump, check the pressure at the pump's inlet port. The pressure drop in the inlet piping should not be greater than 3 psi.

b. While transferring liquid with the pump, close the discharge valve(s) so the full flow will be directed back to the storage tank through the by-pass valve. Then slowly close the valve downstream of the by-pass valves. The discharge pressure of the pump should increase to the maximum differential pressure of the pump at no flow conditions (see Appendix C: Performance Curves).

c. If the maximum differential pressure is not obtained, the pump must be serviced. See Appendix F Troubleshooting Guide for additional help.

d. Replace vanes or sideplates if worn.

7. Tighten all hold-down bolts.

8. Inspect motor starter contact points.

This procedure must be performed by an authorized and qualified electrician according to the electric motor manufacturer's guidelines.

Stationary Coro-Vane® Seal Replacement Instructions

Simple as A, B, C ... but watch alignments A, B and C or your new seal will leak!

Caution: Bleed all pressure from the pump and piping before starting to install your seal assembly.

Cleanliness

Even the smallest amount of dirt on your new seal can cause early failure. Keep all parts, tools and your hands clean while installing the seal. Never touch the smooth lapped faces of the carbon rotor or seal seat. For LP-Gas, anhydrous ammonia and similar liquids, you are trying to seal a fluid that is 5 to 10 times thinner than water! Your new seal needs every chance it can get, so keep it clean.

Workmanship

Your Corken pump is a precision piece of equipment with very close clearances. Treat it as such. Never beat on it to get parts in or out.

Bill of Materials for each Coro-Vane® Seal Assembly or Replacement Seal

Assembly	Description	Part Number	Description	Qty
1769-X _{1,3}	Seal assembly, cast iron seal	1769-X1	Bearing housing assembly	1
		1822	Seat adapter plate	1
		2-128 ₁	O-ring	1
		2-240 ₁	O-ring	1
		2298-X ₂ ¹	Cast iron	1
		2755	Bearing inner race	1
1769-XR _{1,3}	Seal replacement, cast iron	2-128 ₁	O-ring	1
		2-240 ₁	O-ring	1
		2298-X ₂ ¹	Cast iron seal	1
1769-X ₂ ¹	Seal assembly, Ni-resist	1769-X1	Bearing housing assembly	1
		1822	Seat adapter plate	1
		2-128 ₁	O-ring	1
		2-240 ₁	O-ring	1
		2298-X ₃ ¹	Ni-resist seal	1
		2755	Bearing inner race	1
1769-XR ₂ ¹	Seal replacement, Ni-resist	2-128 ₁	O-ring	1
		2-240 ₁	O-ring	1
		2298-X ₃ ¹	Ni-resist seal	1

O-ring Code	
A	Buna-N
B	Neoprene ^{®2}
D	Viton ^{®2}
E	Teflon ^{®2}
G	Ethylene Propylene ^{®2}
K	Kalrez ^{®2}

¹ _ denotes O-ring code. See chart to the right for details.

² Registered trademarks of the DuPont company

³ Not available in Teflon®, use 1769-XE2 or 1769-XE2R

STEP 1

Depressurize and open the pump.

FOLLOW ESTABLISHED SAFETY REGULATIONS!

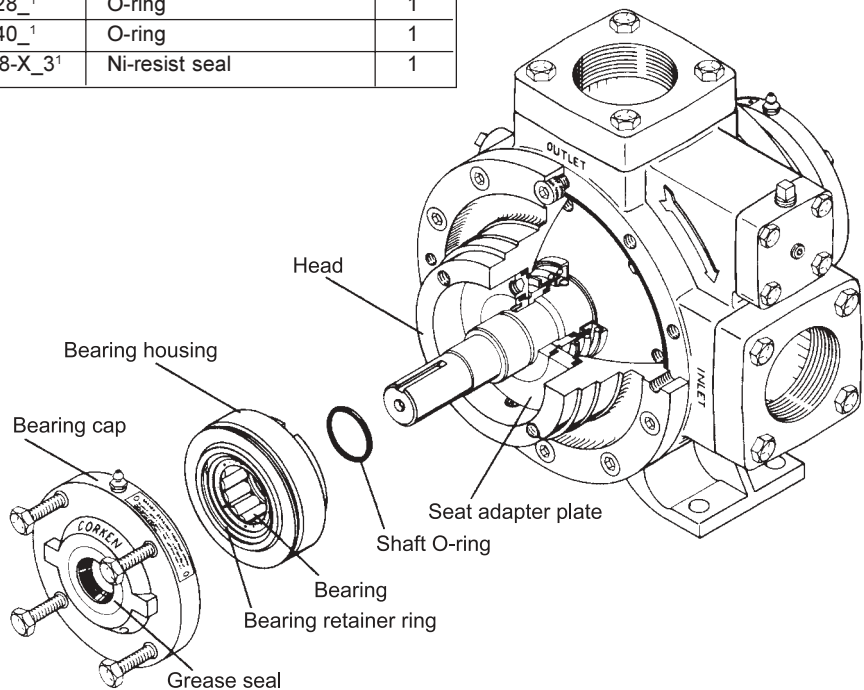

Remove the bearing cap and bearing housing. Should the bearing housing be rusted or frozen in place it may be necessary to remove the entire pump head. The housing can then be driven out gently with a block of wood.

Remove the old shaft O-ring and discard it. Never reuse an old O-ring except in an emergency. If you are also installing a new bearing or grease seal do so now.

STEP 2

Remove the old seal.

KEEP IT CLEAN!

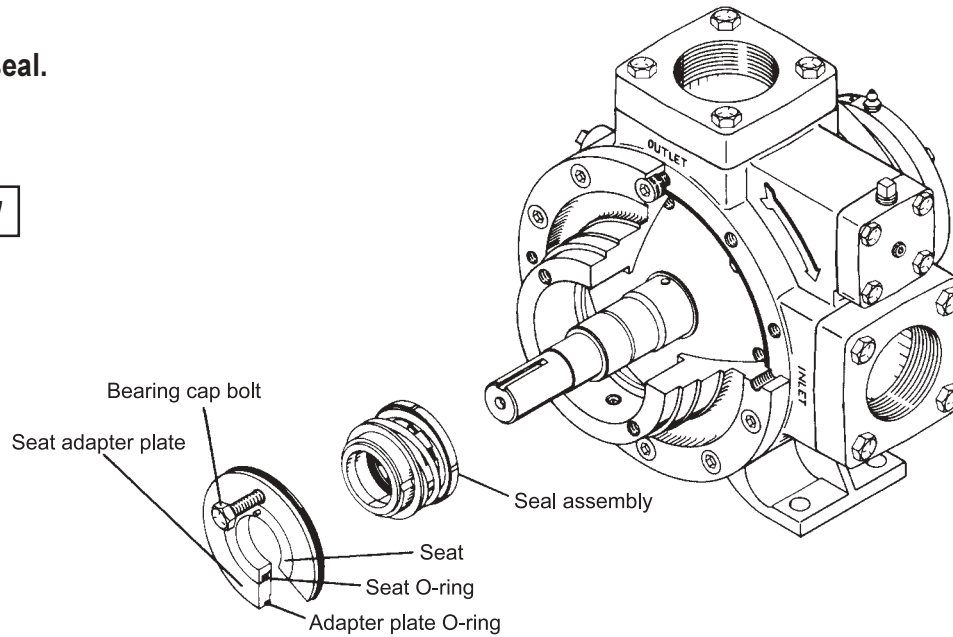

The seat adapter plate can be removed using a bearing cap bolt as a puller. Disregard the old adapter plate O-ring, seat and seat O-ring. Remove and discard the rest of the old seal. Thoroughly clean all surfaces that contact O-rings.

Use fine emery or crocus cloth. The shaft under the seal O-ring should be shiny smooth. Lubricate all surfaces with a clean, light oil. Do not let dirt settle on the parts.

STEP 3

Proper alignment.

**WATCH ALIGNMENTS
A and B!**

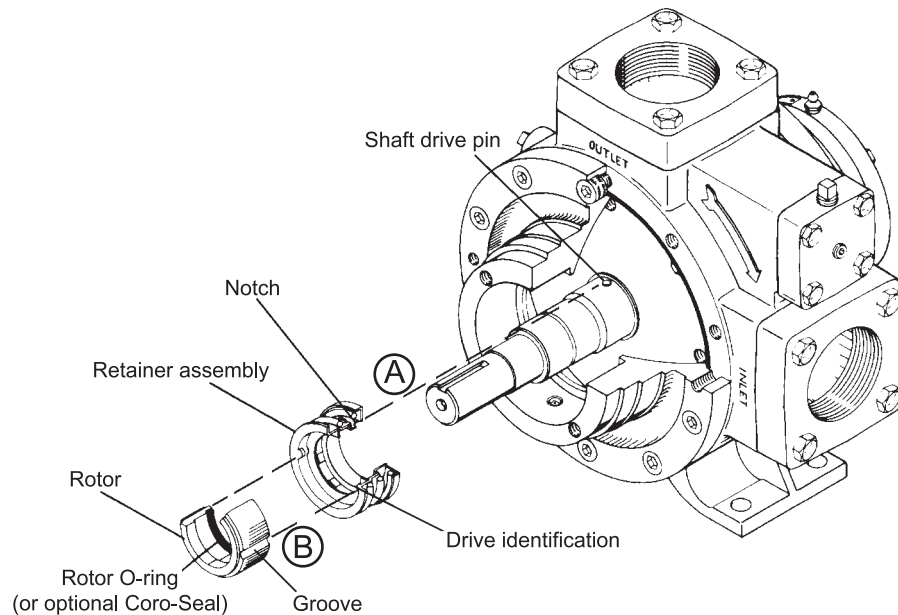

This is the most critical part of your seal installation. Be sure your hands are clean. Unwrap your new seal and make certain you do not touch the seal faces.

- A.** Install the retainer assembly, locating the notch over the shaft drive pin. If the pin is not in the notch, the seal will be improperly positioned and will leak. It should not require any force to install the retainer assembly.

Hold the carbon rotor without touching the lapped face, lubricate the rotor O-ring with a light oil and install both on the pump shaft. (For optional Teflon®¹ Coro-Seal installation see the following paragraph.)

If you are using the optional Teflon®¹ Coro-Seal make sure the shaft is very clean and smooth as the Teflon®¹ seal is not as tolerant of surface blemishes as the rubber type O-ring. After lubricating the Coro-Seal install in back of carbon rotor with the spring toward you, and then slide the carbon rotor in position as previously described.

- B.** The two grooves in the carbon rotor must line up with the drive indentations in the retainer assembly. If they do not, the seal will be improperly positioned and will leak. Do not allow the carbon rotor to cock or you may chip the lapped face.

¹Registered trademark of the DuPont company

STEP 4

Completing the installation.

Oil first and place the new adapter plate O-ring into the pump head. Put the new seat and oiled seat O-ring into the adapter plate without touching the lapped face. Install the adapter plate in the pump head. Put the shaft O-ring on the shaft.

- C. Slide the bearing housing into the head locating the slot in the bearing housing over the pin in the back of the seat. If the pin is not in the slot, the seal will be improperly positioned and will leak. Install the bearing cap using a criss-cross method on the bolts. Make sure the pump turns freely.

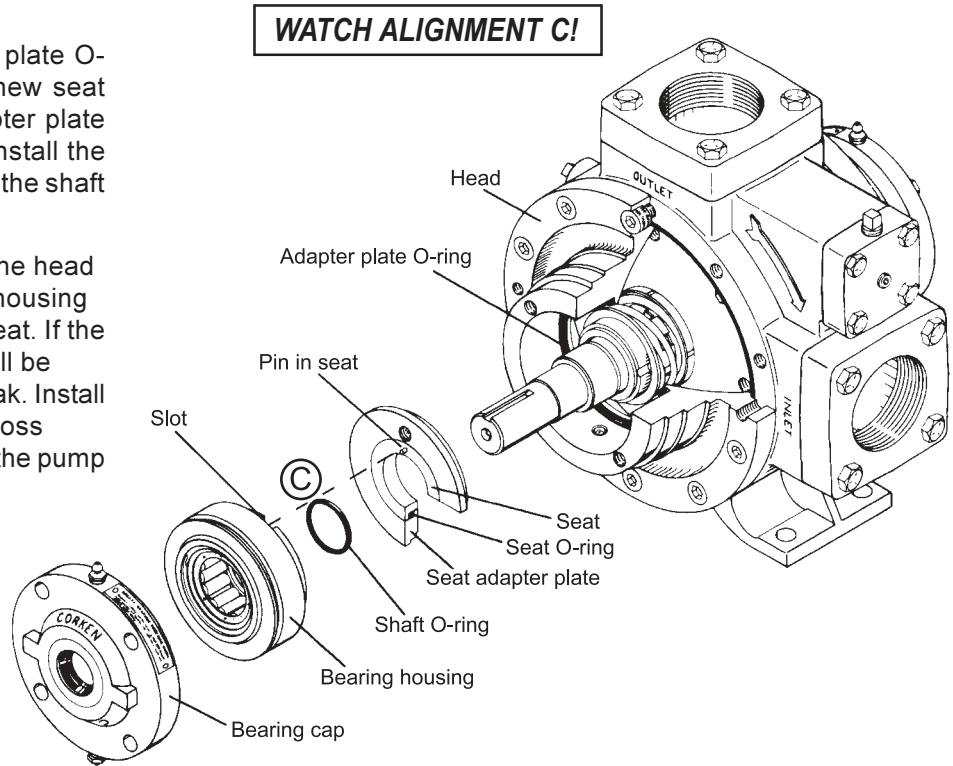

STEP 5

Proper lubrication.

Regrease the bearings after thoroughly cleaning the grease openings and fittings. If dirt is forced into the bearings, early failure will result.

Special relief fittings have been provided to prevent over-greasing the bearings. Excessive grease may drip out for several hours after lubrication. Over-greasing will damage the pump bearings. Use only a recommended ball bearing grease. Using a hand grease gun, put the grease in as slowly as possible and stop as soon as the relief fitting opens.

**DO NOT
OVERGREASE!**

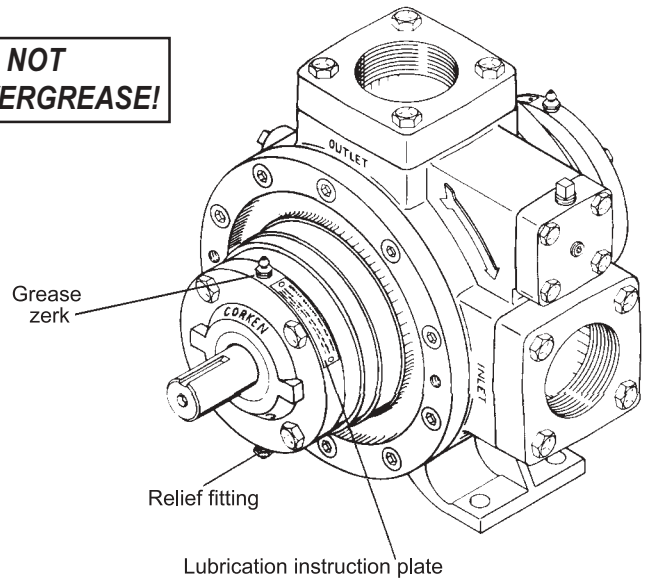

STEP 6

Repressurize the system.

Best results are usually obtained by slowly pressurizing the vapor pressure. Liquid entering the pump, even slowly, can sometimes refrigerate enough to keep seal elastomers from reaching their proper sealing positions thereby causing leakage.

**VAPOR FIRST,
THEN LIQUID!**

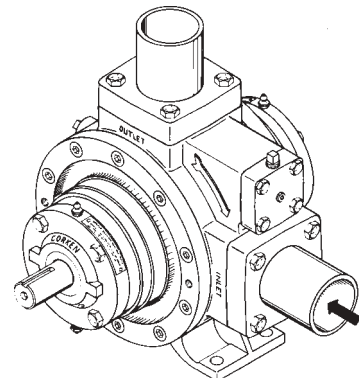

Parts Details For A Stationary Coro-Vane® Seal Assembly Models C51 and F51

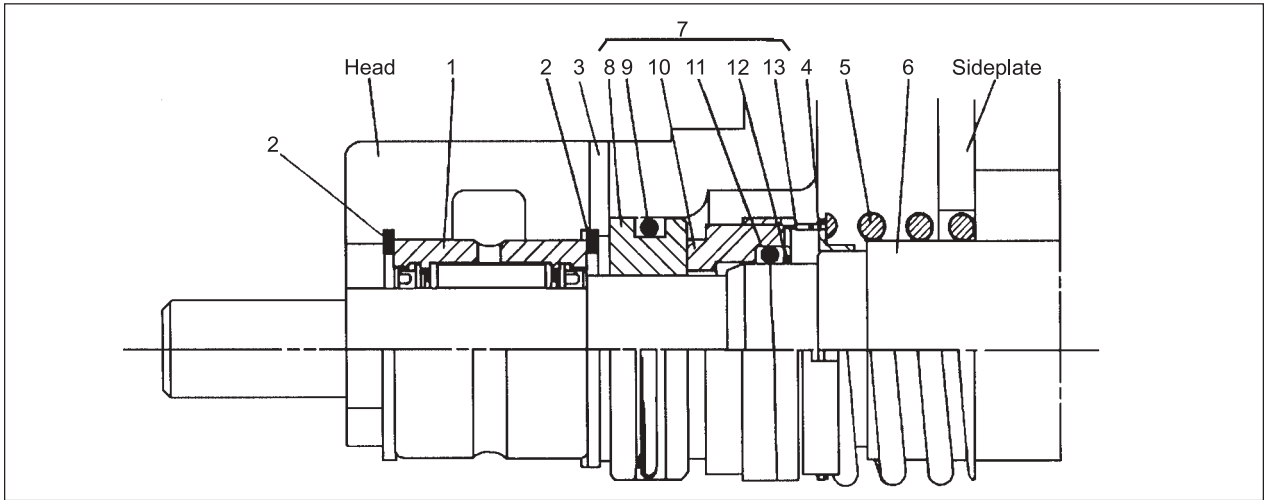

CAUTION: Always relieve pressure in the unit before attempting any repairs.

NOTE: See complete seal replacement instructions starting on page 10.

Ref No.	Part No.	Description	Qty
1	2471	Roller bearing	1
2	5000-112	Retainer ring	1
3	2595	Seat location pin	1
4	2735	Drive band (w 2492-X)	1
5	3471	Spring (w 2492-X)	1
6	2492-X	Rotor & shaft assembly	1
7	2296-1X__ ^{1,4}	Seal Assembly	1
8	^{2,3}	Seat	1
9	^{2,3}	Seat O-ring	1
10	^{2,3}	Rotor	1
11	^{2,3}	O-ring	1
12	^{2,3}	Disc	1
13	^{2,3}	Retainer	1

¹ __ denotes O-ring code and/or seal seat code. See charts to the right for details.

² Not sold separately

³ These items are included in both the seal and the seal assembly.

⁴ Seal assembly includes the seal and a 2-154__¹ case O-ring.

⁵ Neoprene® and Viton® are registered trademarks of the DuPont company.

Seal Part Number

Seal Seat	O-ring Materials		
Material	Buna-N	Neoprene® ⁵	Viton® ⁵
Ceramic	2296-XA1	2296-XB1	2296-XD1
Ni-Resist	2296-XA2	2296-XB2	2296-XD2
S.S.	2296-XA3	2296-XB3	2296-XD3
Tungsten Carbide	2296-XA4	2296-XB4	2296-XD4
Cast Iron	2296-XA5	2296-XB5	2296-XD5

Complete Seal Assembly Part Number

Seal Seat	O-ring Materials		
Material	Buna-N	Neoprene® ⁵	Viton® ⁵
Ceramic	2296-1XA1	2296-1XB1	2296-1XD1
Ni-Resist	2296-1XA2	2296-1XB2	2296-1XD2
S.S.	2296-1XA3	2296-1XB3	2296-1XD3
Tungsten Carbide	2296-1XA4	2296-1XB4	2296-1XD4
Cast Iron	2296-1XA5	2296-1XB5	2296-1XD5

Parts Details For A Stationary Coro-Vane® Seal Assembly (1769-XRA) Models 521, 1021, F1021 and F1521

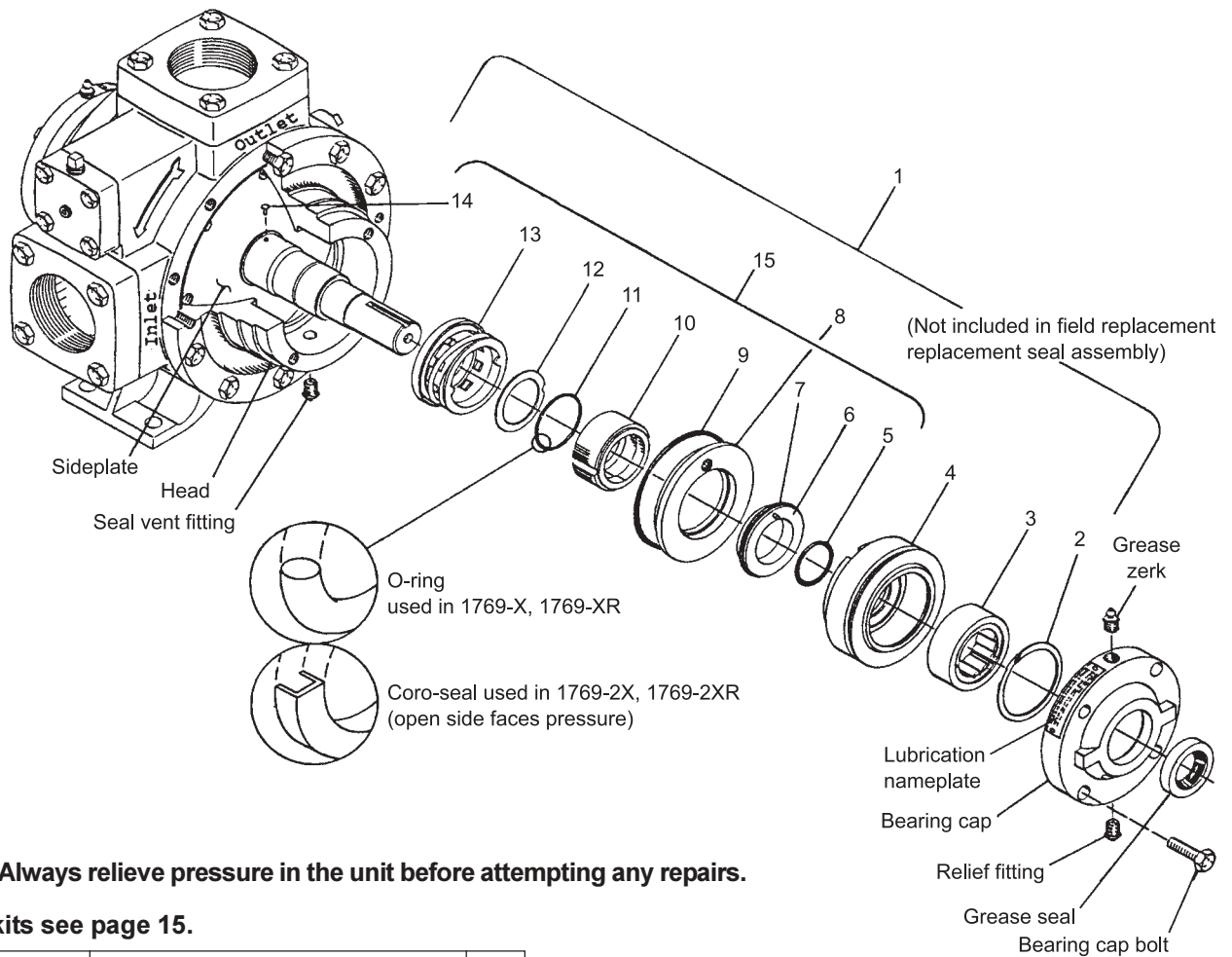

CAUTION: Always relieve pressure in the unit before attempting any repairs.

For repair kits see page 15.

Ref. No.	Part No.	Description	Qty
1	1769-X_	Complete seal assembly ¹	1
	1769-2X	Complete seal assy Coro-Seal	1
2	2760-244	Retainer ring	1
3	2754-X	Roller bearing, complete	1
	2754	Bearing outer race	1
	2755	Bearing inner race	1
4	1769	Bearing housing	1
5	2-128_ ³	Shaft O-ring ¹	1
6	—	Seat	1
7	2-227_	Seat O-ring ¹	1
8	1822	Seat adapter plate	1
9	2-240_	Adapter plate O-ring ¹	1
10	—	Carbon	1
11	2-223_	Rotor O-ring ¹	1
12	—	Disc	1
13	—	Retainer assembly	1
14	2701	Drive pin	1
15	1769-XR_	Field replacement seal assembly ¹	1
	1769-2XR_	Field repl. seal assy Coro-Seal ¹	1

O-ring Code	
A	Buna-N
B	Neoprene ^{®2}
D	Viton ^{®2}
E	Teflon ^{®2}

¹ _ denotes O-ring code. See chart to the right for details.

² Registered trademark of the DuPont company

³ Available in Buna-N only

Repair Kits and Spare Parts For Stationary Coro-Vane® Pumps

C51/F51 Standard Repair Parts (no kit available)

2296-1X_5	Seal assembly	1
2451-2	Vane	8
2-154_	Case O-ring	2
2491	Sideplate	2

521 Repair Kit 2904-X2¹

1163-2	Sideplate	2
1168-7	Vane	10
1358	Grease seal	2
1769-XRA	Seal assembly (replacement)	2
2-112A	O-ring, Buna-N	1
2-224A	O-ring, Buna-N	1
2-227A	O-ring, Buna-N	2
2-234A	O-ring, Buna-N	2
2-261A	O-ring, Buna-N	2
2010	Flange gasket	3
2014	Grease seal, thrust	1
2754-X	Roller bearing	2

1021/F1021 Repair Kit 2906-X2¹

1209-1	Sideplate	2
1308-9	Vane	10
1358	Grease seal	2
1769-XRA	Seal assembly (replacement)	2
2-112A	O-ring, Buna-N	1
2-228A	O-ring, Buna-N	1
2-245A	O-ring, Buna-N	2
2-249A	O-ring, Buna-N	2
2-268A	O-ring, Buna-N	2
2014	Grease seal, thrust	1
2754-X	Roller bearing	2

F1521 Repair Kit 2907-X3¹

1358	Grease seal	2
1769-XRA	Seal assembly (replacement)	2
2-234A	O-ring, Buna-N	3
2-238A	O-ring, Buna-N	1
2-245A	O-ring, Buna-N	1
2-249A	O-ring, Buna-N	1
2-268A	O-ring, Buna-N	2
2014	Grease seal, thrust	1
2754	Bearing outer race	2
3209	Ball bearing	1
3476-L	Sideplate, left	1
3476-R	Sideplate, right	1
3477	Vane	6

C51/F51 Additional Spare Parts

For complete list of parts see page 16

2492-X	Rotor & shaft assembly	1
2471	Roller bearing	2

521 Additional Spare Parts

For complete list of parts see page 18 and 19

1166-1X1R	Rotor & shaft assembly	1
1162-2	Cam (liner)	1

1021/F1021 Additional Spare Parts

For complete list of parts see page 18–20

1208-1X1R	Rotor & shaft assembly	1
1201-2	Cam (liner)	1

F1521 Additional Spare Parts

For complete list of parts see page 21

3350-X1R	Rotor & shaft assembly	1
1792-1	Cam (liner)	1

¹All repair kits have Buna-N O-rings which are suitable for both LPG and NH₃ applications.

Parts Details For Stationary Coro-Vane® Pumps Models C51 and F51

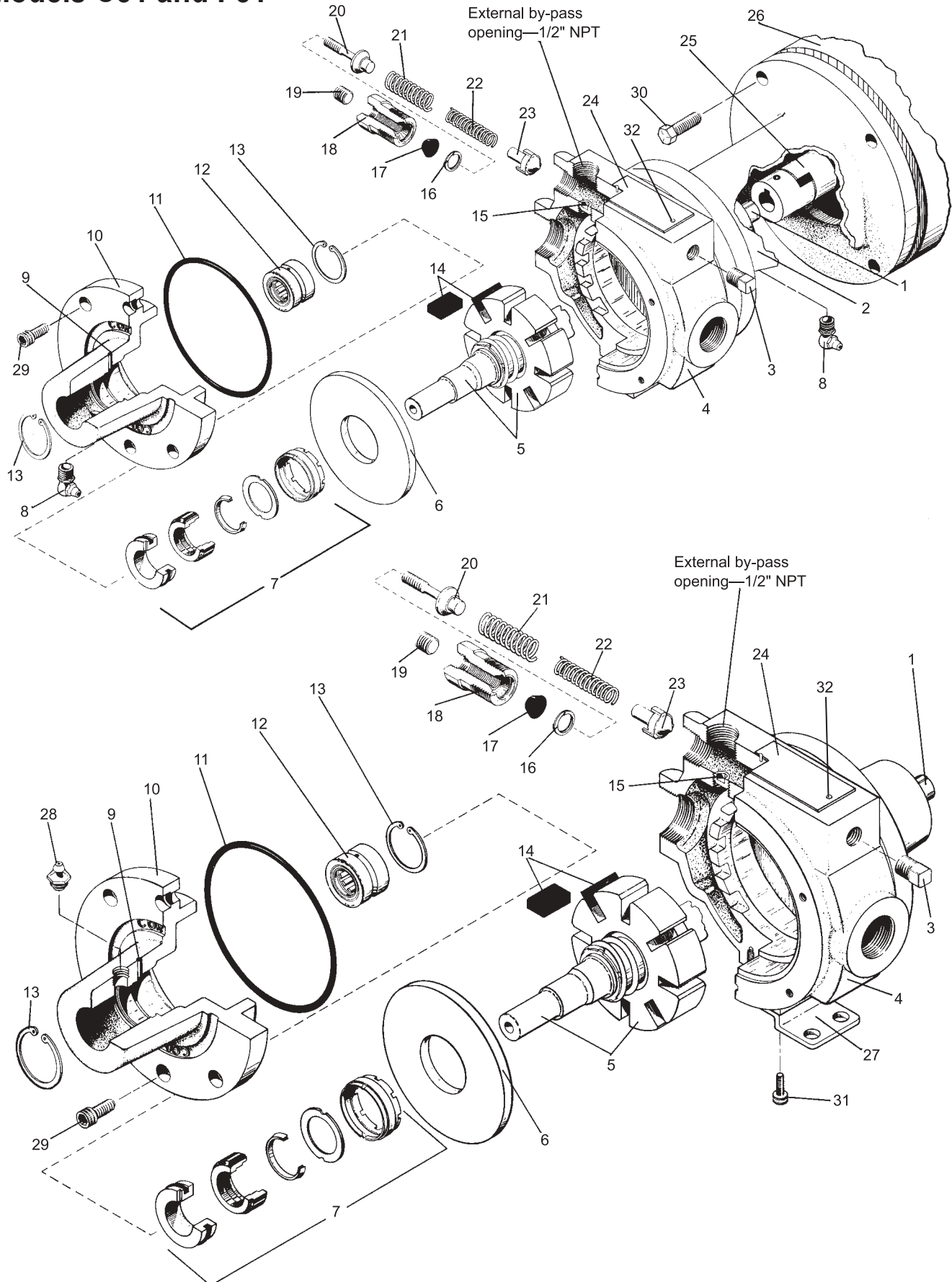

Parts Details For Stationary Coro-Vane® Pumps Models C51 and F51

CAUTION: Always relieve pressure in the unit before attempting any repairs.

Ref. No.	Part No.	Description	Qty
1	2592	Key 1/8" sq. x 9/16"	1
2	2510	Mounting bracket (mod. C51)	1
3	3442	Pipe plug 1/4" NPT	1
4	2468	Case (model C51)	1
	2468-1	Case (model F51)	1
5	2492-X	Rotor & shaft assembly	1
6	2491	Sideplate	2
7	2296-1X ₁	Seal assembly	2
8	2604	Elbow grease zerk 1/8" NPT (model C51)	2
	2159	Lubricap #2 (not shown)	2
9	2595	Seat location pin	2
10	2472	Head	2
11	2-154 ₁	Case O-ring	2
12	2471 ³	Roller bearing	2
13	5000-112	Retainer ring	4
14	2451-2	Carbon vane	8
15	2590 ²	Flush seal plug 1/8" NPT	1
16	2760-53	Retainer ring	1
17	2589	Stem seal	1

Ref. No.	Part No.	Description	Qty
18	2585	Relief valve plug	1
19	2590	Flush seal plug 1/8" NPT	1
20	2584-X	Adjusting stem assembly	1
21	2587 ²	Outer relief valve spring	1
22	2586 ²	Inner relief valve spring	1
23	2588	Relief valve	1
24	2591	nameplate	1
25	2593-1	Coupling with spider (C51)	1
	2774	Coupling spider only (C51)	1
26	2767	1/2 hp 50/60 Hz motor (C51)	1
27	2594	Base (model F51)	1
28	2158	Grease zerk 1/8" NPT (F51)	2
	2159	Lubricap #2 (not shown)	2
29	7002-025 NC062A	Bolt soc head (model C51)	9
	7002-025 NC062A	Bolt soc head (model F51)	12
30	7001-037 NC100A	Bolt hex head	4
31	7002-010 NC050A	Bolt soc head	3
32	7012-006 SF019E	Nameplate screw	2

¹ _ denotes O-ring code

O-ring Code	
A	Buna-N
B	Neoprene ^{®4}
D	Viton ^{®4}
E	Teflon ^{®4}

²The pump relief valve is installed at the factory to operate as an external bypass through the 1/2" NPT hole back to the storage tank. To change from this external configuration to an internal relief valve, remove relief valve plug 2585 and relief valve springs 2586 and 2587. Then remove flush seal plug 2590 and plug the 1/2" NPT opening. Replace the relief valve plug and springs. In this case a separate external by-pass valve must be used in the piping between the pump discharge and the storage tank. Set the internal valve at a pressure slightly above the steering on the external valve. Use only the outer relief valve spring 2587 for units with 1/3 hp motors. use both springs for 1/2 hp motors and larger. Always replace the flush seal plug 2590 that screws into the relief valve plug 2585 after any relief valve adjustment.

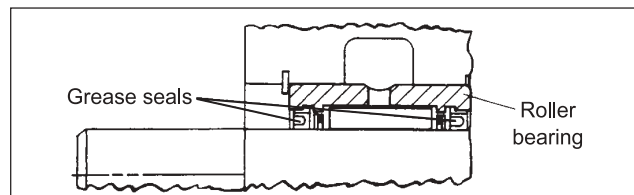

³Bearing replacement: Install roller bearing 2471 with open side of grease seals toward outside of pump as shown below.

⁴Registered trademark of the DuPont company

Parts Details For Stationary Coro-Vane® Pumps Models 521 and 1021

CAUTION: Always relieve pressure in the unit before attempting any repairs.

Model 521

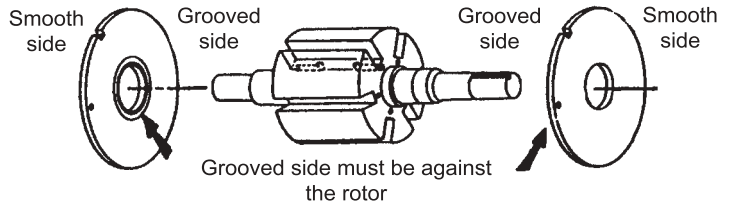

Model 1021

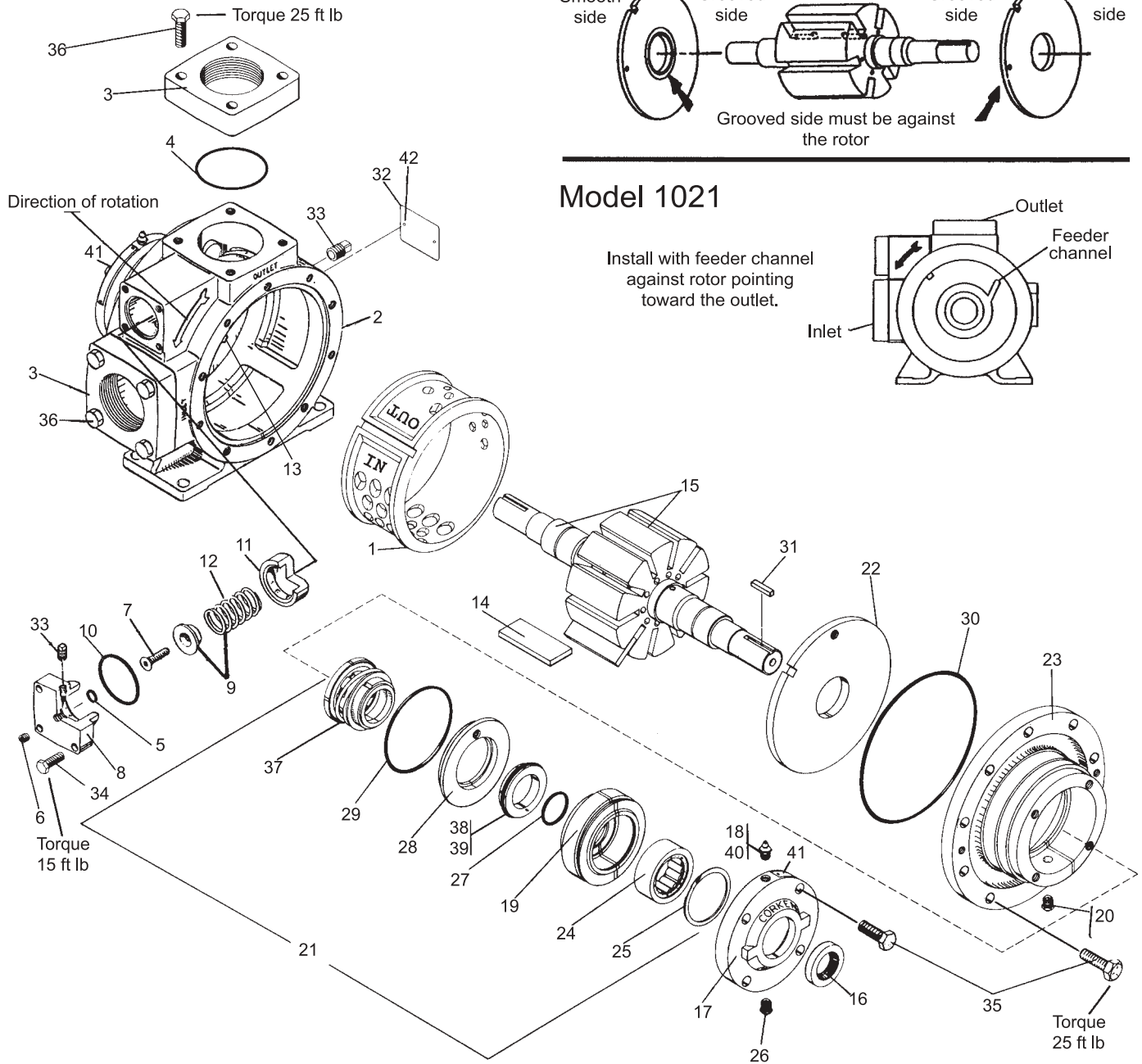
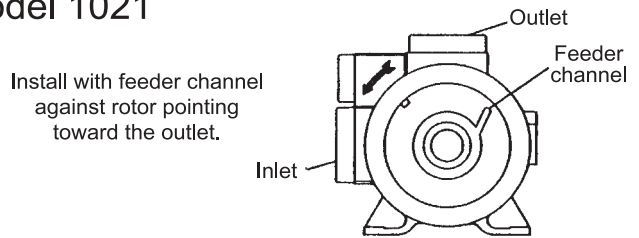

Parts Details For Stationary Coro-Vane® Pumps Models 521 and 1021

Ref. No.	Part No.	Description	Qty
1	1162-2	Cam (521)	1
	1201-2	Cam (1021)	1
2	2832	Case (521)	1
	2841	Case (1021)	1
3	1172-2.5 ³	2.5" Flange (521)	1
	1172-2 ³	2" Flange (521)	1
	1206-3 ⁴	3" Flange (1021)	2
4	2-234_ ²	Flange O-ring (521)	2
	2-245_ ²	Flange O-ring 3" (1021)	2
	2-249_ ²	Flange O-ring 4" (1021)	2
5	2-112_ ²	Adjusting screw O-ring	1
6	2590	Flush seal plug 1/8" NPT	1
7	2252	Relief valve adjusting screw	1
8	1174	Valve cap (521)	1
	1207	Valve cap (1021)	1
9	1242-X	Relief valve spring & guide (521)	1
	1227	Relief valve spring guide (1021)	1
10	2-224_ ²	Relief valve cap O-ring (521)	1
	2-228_ ²	Relief valve cap O-ring (1021)	1
11	1241	Relief valve (521)	1
	1224	Relief valve (1021)	1
12	1242	Relief valve spring (521)	1
	1226	Relief valve spring (1021)	1
13	1170	Cam key (521)	1
	1309	Came key (1021)	1
14	1168-7	Blade (521)	10
	1308-9	Blade (1021)	10
15	1166-1X1R	Rotor & shaft assembly (521)	1
	1208-1X1R	Rotor & shaft assembly (1021)	1
16	1358	Grease seal	2
17	1164-1	Bearing cap	2
18	2158	Grease zerk 1/8" NPT	2
19	1769	Bearing housing	2
20	1343	Relief fitting (seal vent)	2
21	1769-X_ ^{1,2}	Seal assembly	2
	1769-XR_ ^{1,2}	Seal assembly—replacement	2
22	1163-2 ⁸	Sideplate (521)	2
	1209-1 ⁸	Sideplate (1021)	2
23	1161-4	Head (521)	2
	1205-4	Head (1021)	2
24	2754-X	Roller bearing—complete	2
	2755	Bearing inner race	2
	2754	Bearing outer race	2
25	2760-244	Retainer ring	2
26	1343	Relief fitting (grease)	2
27	2-128_ ⁷	Shaft O-ring	2
28	1882	Seat adapter plate	2
29	2-240_ ²	Adapter plate O-ring	2
30	2-261_ ²	Case O-ring (521)	2
	2-268_ ²	Case O-ring (1021)	2
31	2270	1/4" Key	2
32	2949	nameplate	1
33	3442	1/4" NPT plug	1

Ref. No.	Part No.	Description	Qty
34	7001-031 NC125A	Hex hd bolt 5/16-18x1-1/4 (521)	4
	7001-037 NC125A	Hex hd bolt 3/8-16x1-1/4 (1021)	4
35	7001-037 NC125A	Hex head bolt 3/8-16x1-1/4 (521)	28
	7001-037 NC125A	Hex head bolt 3/8-16x1-1/4 (1021)	32
	7001-037 NC150A	Hex head bolt 3/8-16x1-1/2	8
37	_____ ⁵	Retainer	2
38	_____ ⁵	Seal seat	2
39	2-227_ ²	Seal seat O-ring	2
40	2159	Lubricap #2	2
41	1359	Lubrication instruction tag	2
42	7003-004	Round head plated drive screw	2
	DR0198	4 x 3/16	

For repair kits see page 15.

¹Seal assemblies are available in two forms:

a. Complete seal kit including bearing housing, seat adapter plate, bearings, retainer ring, seal and O-rings. Part number 1769-X_².

b. Field replacement seal assembly containing only the seal and O-rings. Part number 1769-XR_².

²_ denotes O-ring code

O-ring Code	
A	Buna-N
B	Neoprene [®]
D	Viton [®]
E	Teflon [®]

³Optional flanges, (model 521):

1172-1.5 1/2" NPT

1172-1.5S 1/2" Weld

1172-2 2" NPT

1172-2S2' Weld

1172-2.5 2-1/2" NPT

1172-2.5S 2-1/2" Weld

⁴Optional flanges, (model 1021):

1206-3S 3" Weld

1206-4 4" NPT

1206-4S 4' Weld

⁵Not available separately

⁶Neoprene[®], Viton[®] and Teflon[®] are registered trademarks of the DuPont company

⁷Available in Buna-N only

⁸Sideplate replacement instructions:

Model 1021

Install with feeder channel against rotor pointing toward the outlet.

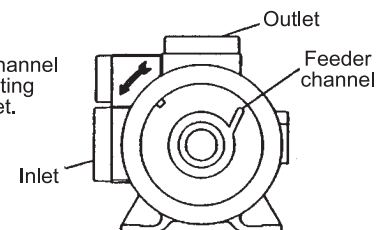

Parts Details For Stationary Coro-Vane® Pump Model F1021

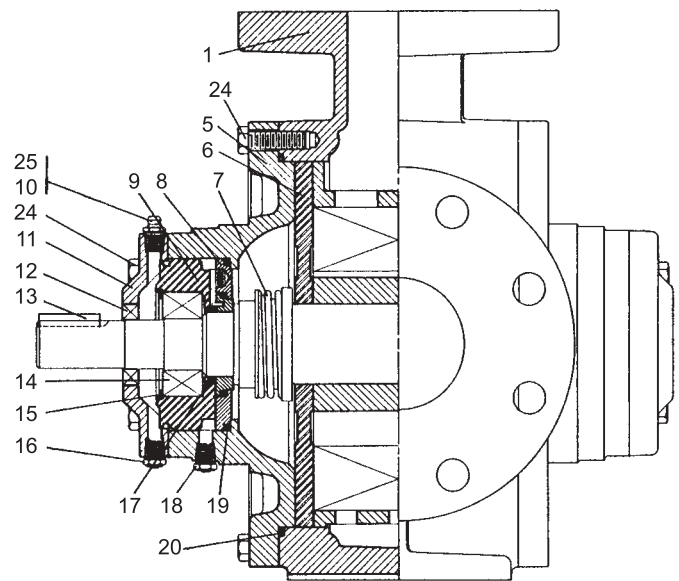
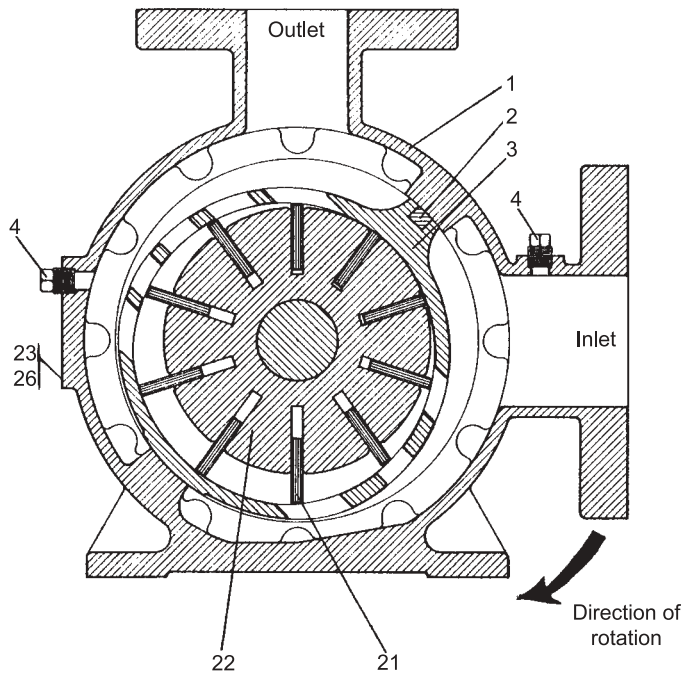

CAUTION: Always relieve pressure in the unit before attempting any repairs.

For repair kits see page 15.

¹Seal assemblies are available in two forms:

- a. Complete seal kit including bearing housing, seat adapter plate, bearings, retainer ring, seal and O-rings. Part number 1769-X₂.
- b. Field replacement seal assembly containing only the seal and O-rings. Part number 1769-XR₂.

²_ denotes O-ring code

O-ring Code	
A	Buna-N
B	Neoprene ^{®3}
D	Viton ^{®3}
E	Teflon ^{®3}

³ Neoprene[®], Viton[®] and Teflon[®] are registered trademarks of the DuPont company.

⁴Available in Buna-N only

⁵Sideplate replacement instructions:

Install with feeder channel against rotor pointing toward the OUTLET.

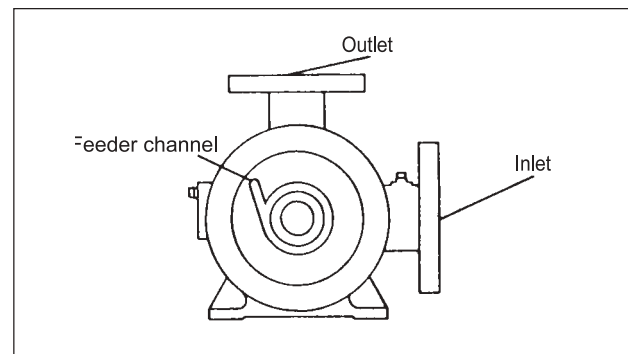

Ref. No.	Part No.	Description	Qty
1	2433	Case	1
2	1309	Cam key	1
3	1201-2	Cam	1
4	3442	1/4" NPT plug	2
5	1205-4	Head	2
6	1209-1 ⁵	Sideplate	2
7	1769-X _{1,2}	Seal Assembly	2
	1769-XR _{1,2}	Seal replacement kit	2
8	1822	Seat adapter plate	2
9	1769	Bearing house	1
10	2158	Grease zerk 1/8" NPT	1
11	1164-1	Bearing cap	2
12	1358	Grease seal	1
13	2270	1/4" Key	1
14	2754-X	Roller bearing—complete	2
	2755	Bearing inner race	2
	2754	Bearing outer race	2
15	2760-244	Retainer ring	1
16	1343	Relie fitting (grease)	2
17	2-128 ₄	Shaft O-ring	1
18	1343	Relief fitting (seal vent)	1
19	2-240 ₂	Adapter plate O-ring	1
20	2-268 ₂	Case O-ring	2
21	1308-9	Vane	10
22	1208-1X1R	Rotor and shaft assembly with 2755	1
23	2649	Nameplate	1
24	7001-037 NC125A	Hex hd bolt 3/8-16x1-1/4"	32
25	2159	Lubricap #2	2
26	7012-006 SF019E	Drive screw 6-32x3/16 pan head	6

Parts Details For Stationary Coro-Vane® Pump Model F1521

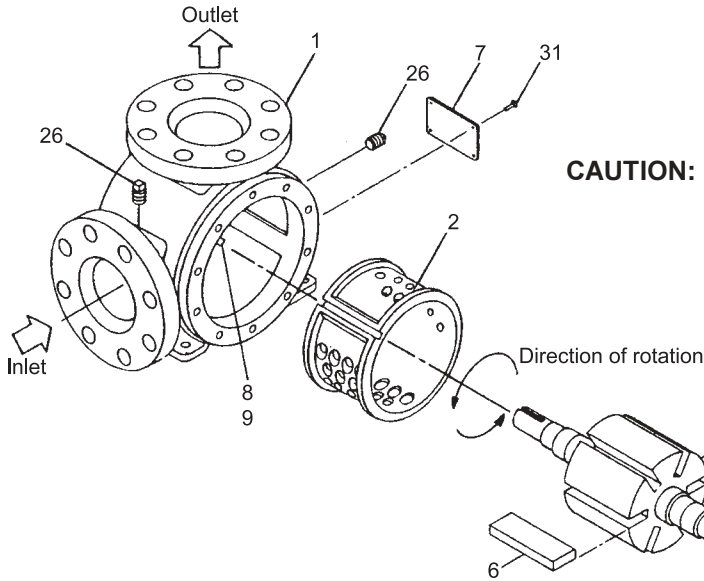

CAUTION: Always relieve pressure in the unit before attempting any repairs.

Ref. No.	Part No.	Description	Qty
1	2437	Case	1
2	1792-1	Cam	1
3	3350-X1R	Rotor & shaft assembly	1
4	3476-R ⁵	Sideplate	1
	3476-L ⁵	Sideplate	1
5	1205-4	Head	2
6	3477	Vane	6
7	2649	Nameplate	1
8	1880	Cam key	1
9	3253	Cam key pin (4 required)	4
10	1769-X ^{1,2}	Seal assembly	2
11	1769-XR ^{1,2}	Seal replacement kit	2
12	_____	Spring retainer	2
13	2-240 ²	Adapter plate O-ring	2
14	1822	Seat adapter plate	2
15	2-223 ²	Seal seat O-ring	2
16	_____	Seat	2
17	2-128 ⁴	Shaft O-ring	2
18	1769	Bearing housing	2
19	2754	Bearing outer race	2
20	2760-244	Retainer ring	2
21	1164-1	Bearing cap	2
22	1358	Grease seal	2
23	2158	Grease zerk 1/8" NPT	2
24	2159	Lubricap 32	2
25	1343	Grease relief fitting	2
26	3442	1/4" NPT plug	2
27	2-268 ²	Case O-ring	2
28	2270	1/4" Key	1
29	1359	Lubrication instruction tag	2
30	7001-037 NC125A	Hex head bolt 3/8-16x1-1/4	32
31	7012-006 SF019E	Pan head screw 6-32x3/16"	6

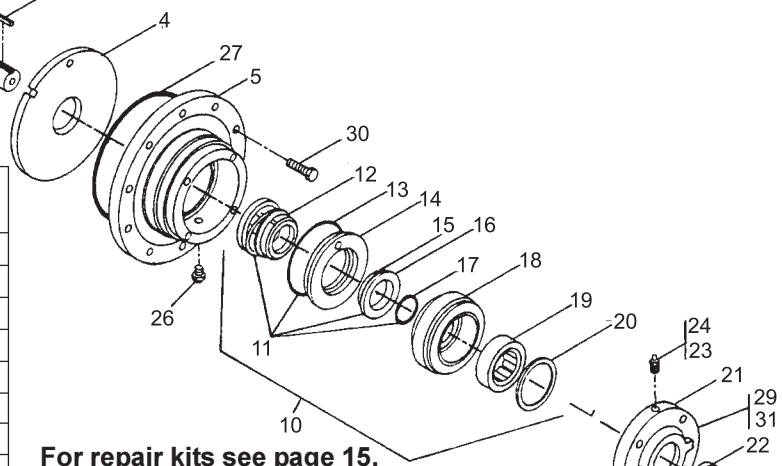

For repair kits see page 15.

¹Seal assemblies are available in two forms:

- a. Complete seal kit including bearing housing, seat adapter plate, bearings, retainer ring, seal and O-rings. Part number 1769-X².
- b. Field replacement seal assembly containing only the seal and O-rings. Part number 1769-XR².

²denotes O-ring code

O-ring Code	
A	Buna-N
B	Neoprene ^{®7}
D	Viton ^{®7}
E	Teflon ^{®7}

³Neoprene[®], Viton[®] and Teflon[®] are registered trademarks of the DuPont company.

⁴Available in Buna-N only

⁵Sideplate replacement: Install with feeder channel against rotor pointing toward the OUTLET.

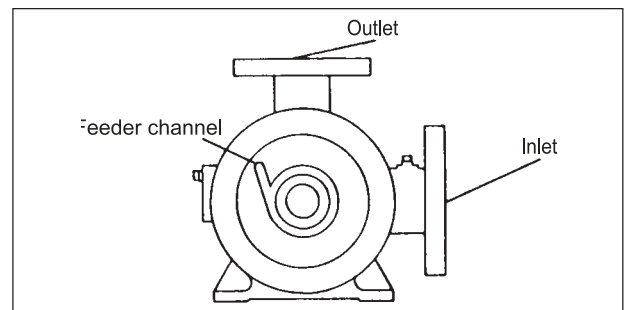

New Part Interference Dimensions Coro-Vane® Pumps

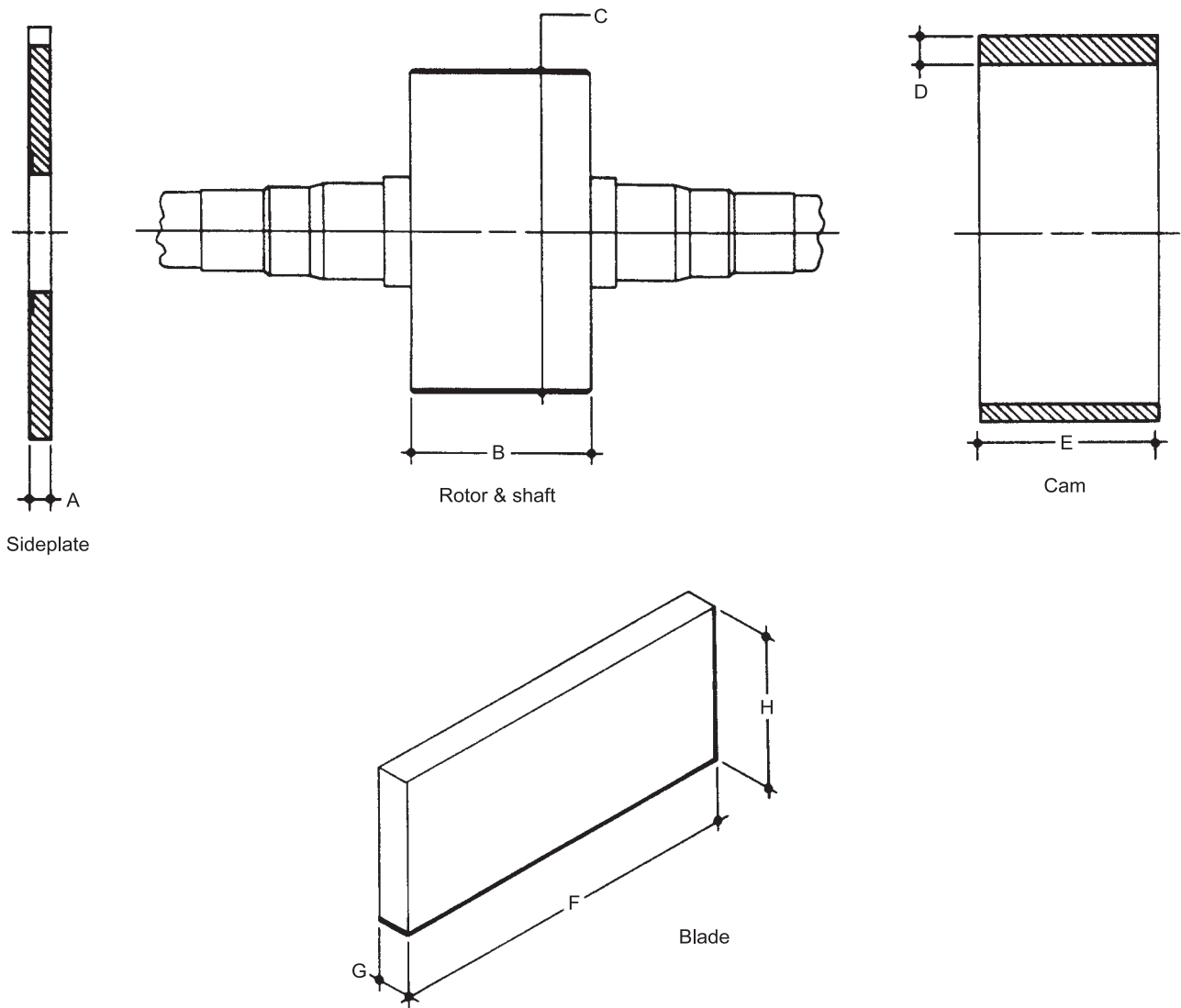

Model	A (min)	B (max)	C (max)	D (max)	E (min)	F (max)	G (max)	H (nominal)
500	0.373	2.992	5.449	0.750	3.000	2.994	0.230	1.323
1000	0.435	3.993	6.249	1.123	4.002	3.997	0.230	1.500
1500	0.435	6.243	6.125	1.184	6.253	6.229	0.549	1.635

Appendix A—Model Number and Identification Code

Models C51, D51, and F51

Product Description

C51	Pump direct mounted to a 1/2 hp fan cooled, capacitor type motor. Motor includes built-in switch and automatic thermal overload for 115 volt, 50/60 Hz, single phase current.
D51	Bare pump with mounting bracket and flexible coupling to close couple the pump to any NEMA 56 or 66 C-face motor. (Note motor is not included)
F51	Frame mounted pump for baseplate mounting (bare pump only)

Base Model	C51	D51	F51
Inlet	1" NPT	1" NPT	1" NPT
Outlet	3/4"	3/4"	3/4"
Weight—bare pump lb (kg)	50 (23)	25 (11.3)	25 (11.3)

Model Number

Base X X X X

Materials Selection			
Pump	Iron	Standard	A
Vanes	Carbon	Standard	D
O-rings	Buna-N	Standard	A
	Neoprene® ¹	No charge option	B
Seal seat	Cast iron	Standard	2

Mounting Option	Model Reference	Part Number	Maximum Motor Frame Size	Ship Weight lb (kg) Mounting Only
Mounting for frame mounted pump (F51) mounting includes steel baseplate and direct drive through flexible coupling.	F51 only	101-12	145T	25 (11.3)

Part Number	Accessory—Options
3000-X4	Hydrostatic test
2296-1XA5	Seal assembly (Buna-N O-rings)
2296-1XB5	Seal assembly (Neoprene® ¹ O-rings)
2451-2	Vanes

¹Neoprene® is a registered trademark of the DuPont company.

Appendix A—Model Number and Identification Code

Models 521, 1021, F1021, and F1521

Base Model	521	1021	F1021	F1521
Inlet	2-1/2" NPT	3" NPT	3" 300# ANSI	4" 300# ANSI
Outlet	2" NPT	3" NPT	2-1/2" 300# ANSI	3" 300# ANSI
Weight—bare pump lb (kg)	132 (60)	200 (91)	200 (91)	235 (107)

Vane Type	10 Vanes	Standard	Standard	Standard	E
	6 Vanes			Standard	F
Vanes	GCB-50	Standard			G
O-rings	Buna-N	Standard			A
	Neoprene® ¹	No charge option			B

Model Number
Base X X X X X

Flange Options (WF=Slip-on weld flange All ANSI flanges are 300# • indicates available flange connections)

Inlet flange

Standard	2-1/2" NPT	•			J
	3" NPT		•		M
	3" ANSI			•	P
	4" ANSI				•
No Cost Options	2" NPT	•			E
	4" NPT		•		Q
Extra Cost Options	2" WF	•			F
	2-1/2" WF	•			K
	3" WF		•		N
	4" WF		•		R

Outlet Flange

Standard	2" NPT	•			E
	3" NPT		•		M
	2-1/2" ANSI			•	L
	3" ANSI				•
No Cost Options	1-1/2" NPT	•			C
	2-1/2" NPT	•			J
	4" NPT		•		Q
Extra Cost Options	1-1/2" WF	•			D
	2" WF	•			F
	2-1/2" WF	•			K
	3" WF		•		N
	4" WF		•		R

Mounting Options

Description	Model	Part Number	Maximum Driver (hp)	Ship Weight (mounting only) lb
Mounting set up for V-belt drive. Includes steel baseplate, adjustable motor slid base, V-belt drive and enclosed beltguard	521	103-9-	245T	422
	1021/F1021	103-10-	284T	560
	F1521	103-11-	284T	630
Mounting set up for use with engine driver through V-belt includes steel baseplate, flexible coupling and guard	All	102-		Consult factory
Mounting set up for direct drive. Includes size B gear reducer, steel baseplate, reducer bracket, couplings and coupling guard	All	101GRB-	254T	Consult factory
Mounting set up for direct drive. Includes size C gear reducer, steel baseplate, reducer bracket, couplings and coupling guard	All	101GRC-	324T	Consult factory

Part Number	Accessory—Options
3000-X1	Hydrostatic test
2904-X2	Repair kit—521
2906-X2	Repair kit—1021/F1021
2907-X3	Repair kit—F1521

¹ Neoprene® is registered trademark of the DuPont company.

Appendix B—Specifications For Models C51 and F51

Operating Specifications

Minimum RPM:	1450	Maximum RPM:	1750
Minimum temperature:	-225°F (-32°C)	Maximum temperature:	225°F (107°C)
Maximum working pressure:	350 psig (25.2 bar g)	Maximum differential pressure:	125 psi (8.6 bar d)
Maximum driver size:	2 hp (1.5 kW)	Flow range:	1–6 gpm (4–23 L/min)

Material Specifications

Part	Model	Standard Material	Optional Material
Case, head rotor	All	Ductile iron ASTM A536	None
Sideplate	All	Gray iron ASTM A48, Class 30	None
Seal seat	All	Cast iron	Ni-Resist cast iron, displacement type ceramic, and tungsten carbide
Seal rotor	All	Carbon	None
Seal metal parts	All	Steel	None
Vanes	All	Carbon	None
Relief valve springs	All	Steel, cadmium plated	None
Relief valve	All	Steel	None
Shaft	All	“Stressproof” steel	None
Mounting bracket	C51	Gray iron ASTM A48, Class 30	None
Base	F51	Steel	None
O-rings	All	Buna-N	PTFE, Viton®, Neoprene® ¹
Relief valve adjusting stem seal	All	Buna-N	None
Retainer rings	All	Steel	None
Bearings	All	Cylindrical roller	None

¹Viton® and Neoprene® are registered trademarks of the DuPont company.

Appendix B—Specifications For Models 521, 1021, F1021, and F1521

Operating Specifications

	Model			
	521	1021	F1021	F1521
RPM range	420–950	420–950	420–950	420–860
Temperature range	-25°F (-32°C) to 225°F (107°C)			
Maximum working pressure psig (bar g)	400 (28.6)	400 (28.6)	400 (28.6)	400 (28.6)
Maximum differential pressure psid (bar d)	125 (8.6)	125 (8.6)	125 (8.6)	100 (6.9)
Maximum driver size hp (kW)	10 (7.5)	20 (15)	20 (15)	30 (22)
Flow range gpm	30–85	65–195	65–195	155–325

Flange Options

Model		Standard	No Cost Option	Extra Cost Option
521	Inlet	2-1/2" NPT	2" NPT	2", 2-1/2" weld flange
	Outlet	2" NPT	1-1/2", 1-1/1" NPT	1-1/2", 2", 2-1/2" weld flange
1021	Inlet	3" NPT	4" NPT	3", 4" weld flange
	Outlet	3" NPT	4" NPT	3", 4" weld flange
F1021	Inlet	3" 300# ANSI	–	–
	Outlet	2-1/2" 300# ANSI	–	–
F1521	Inlet	4" 300# ANSI	–	–
	Outlet	3" 300# ANSI	–	–

Material Specifications 521/1021/F1021/F1521

Part	Model	Standard Material	Optional Material
Case, head, flange rotor, seat adapter plate	All	Ductile iron ASTM A536 Class 30	None
Cam, sideplate, bearing cap	All	Gray iron ASTM A48 Class 30	None
Welding flange	All	Steel	None
Seal seat	All	Gray iron ASTM S48, Class 30	316 SS
Seal metal parts	All	Steel	None
Shaft	521, 1021	"Stressproof" steel	None
	1521	8620 steel	None
Vanes	All	Plastic	None
Relief valve spring	521, 1021	Steel, cadmium plated	None
Relief valve	521, 1021	Steel	None
Bearing	All	Cylinder roller	None
O-rings	All	Buna-N	PTFE, Viton®, Neoprene® ¹
Retainer rings	All	Steel	None

¹Viton® and Neoprene® are registered trademarks of the DuPont company.

Appendix C—Performance Curves For Models C51 and F51

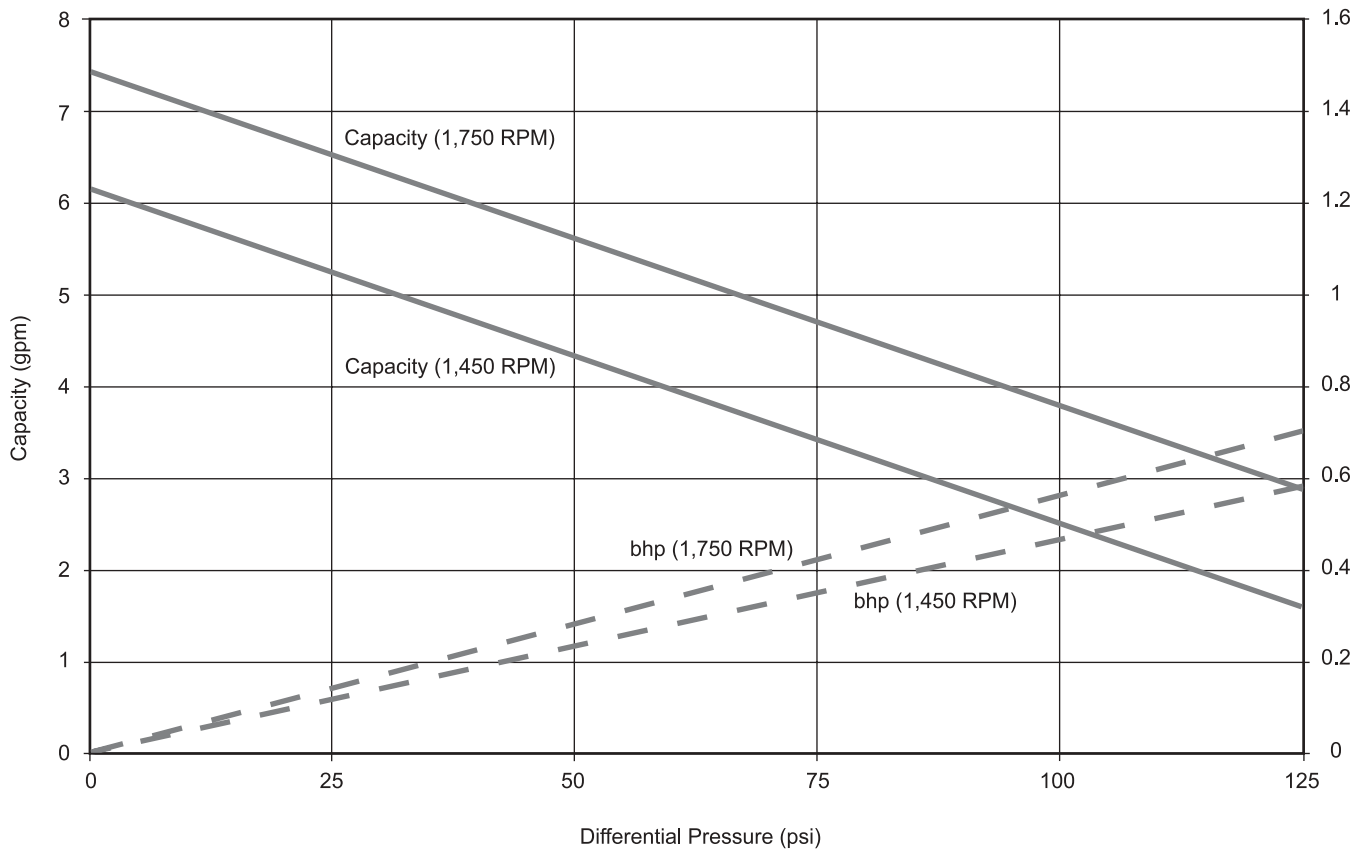

Appendix C—Performance Curves For Model 521

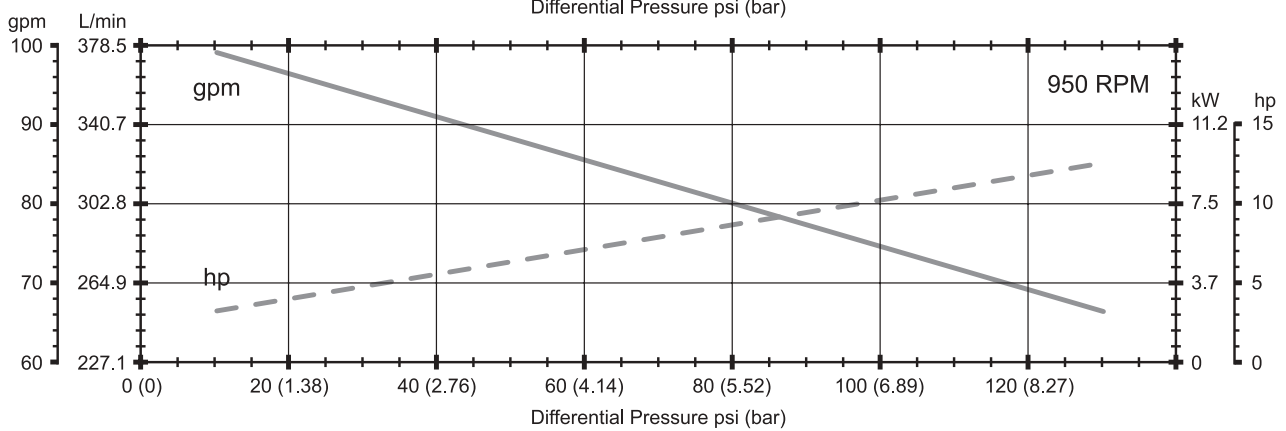
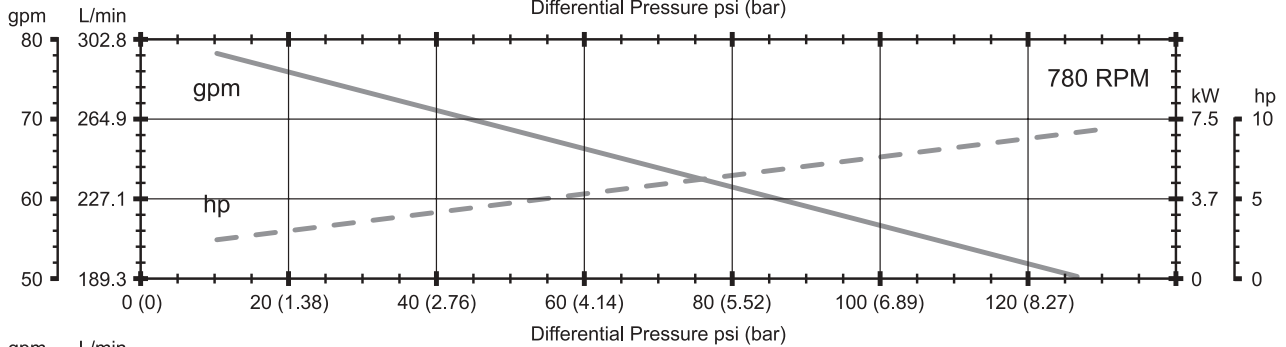
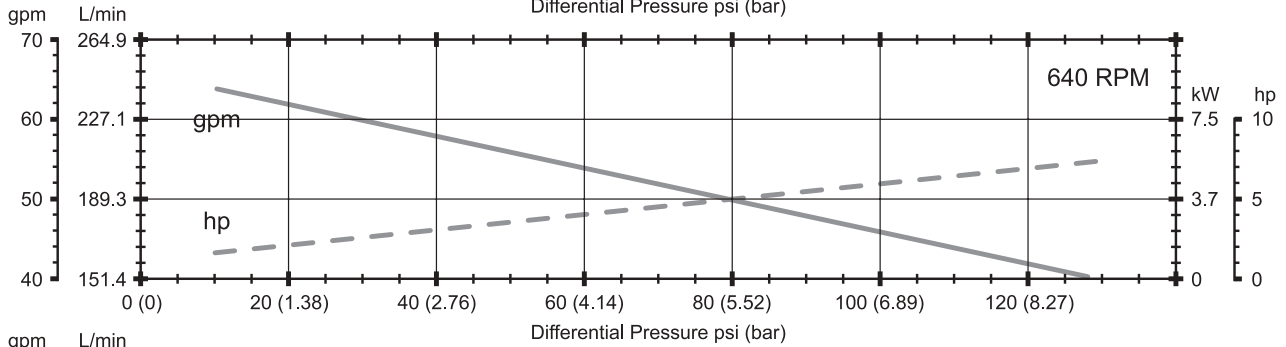
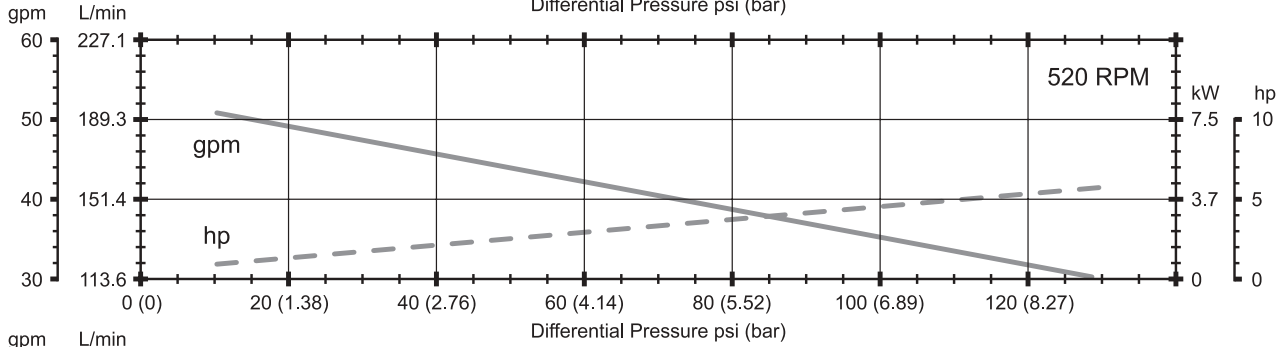
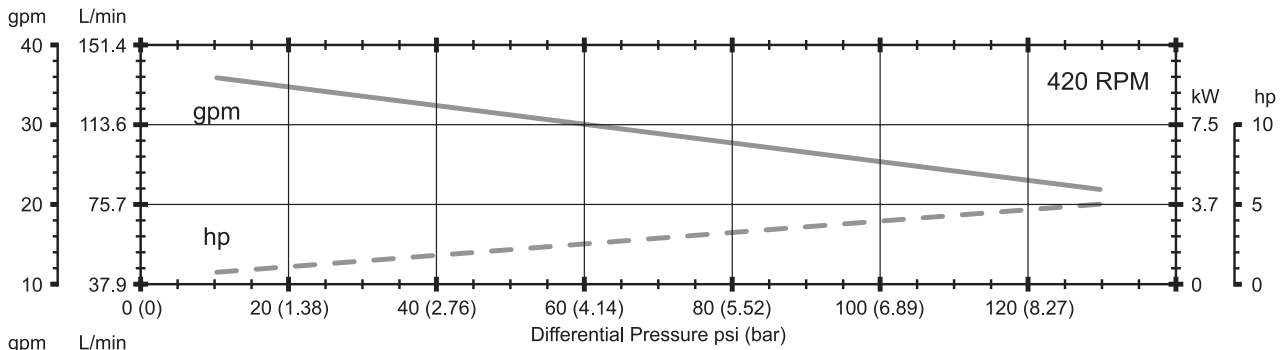

Appendix C—Performance Curves For Model 1021

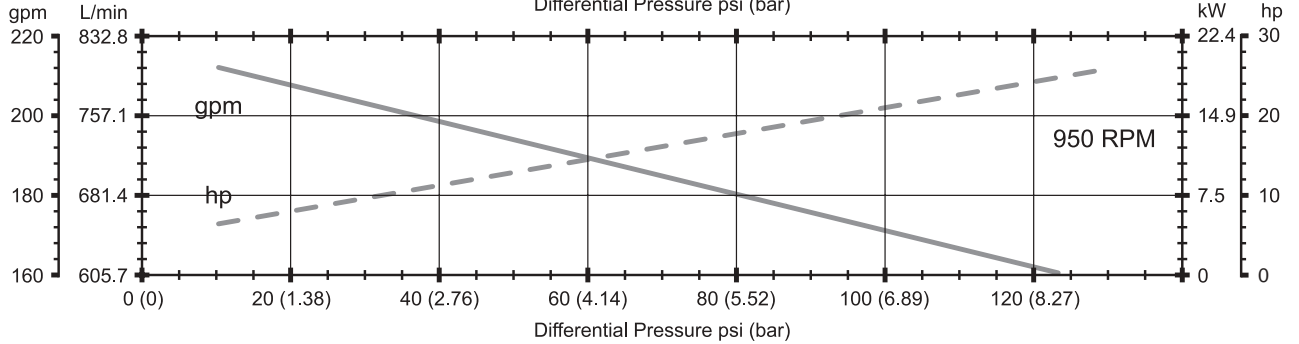
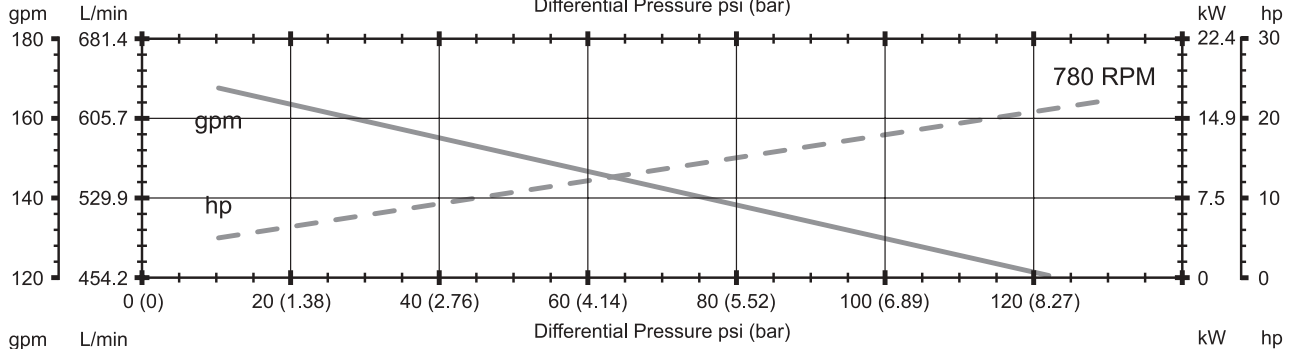
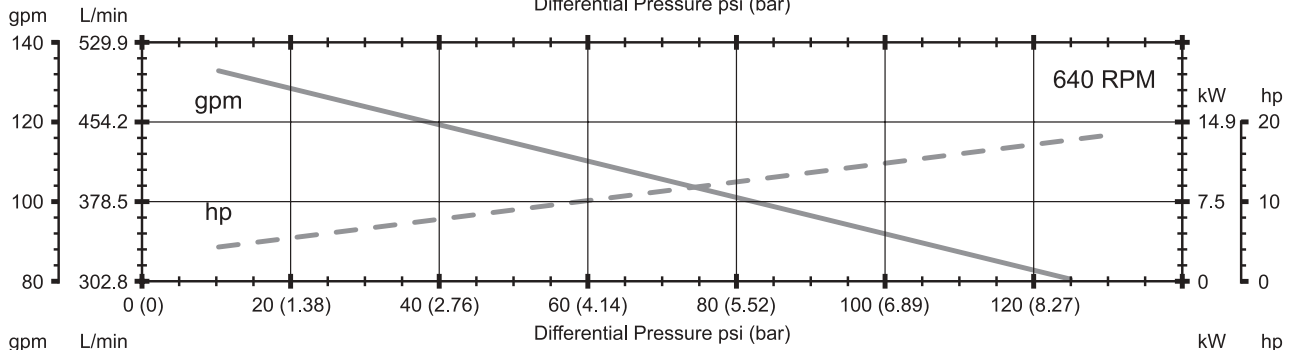
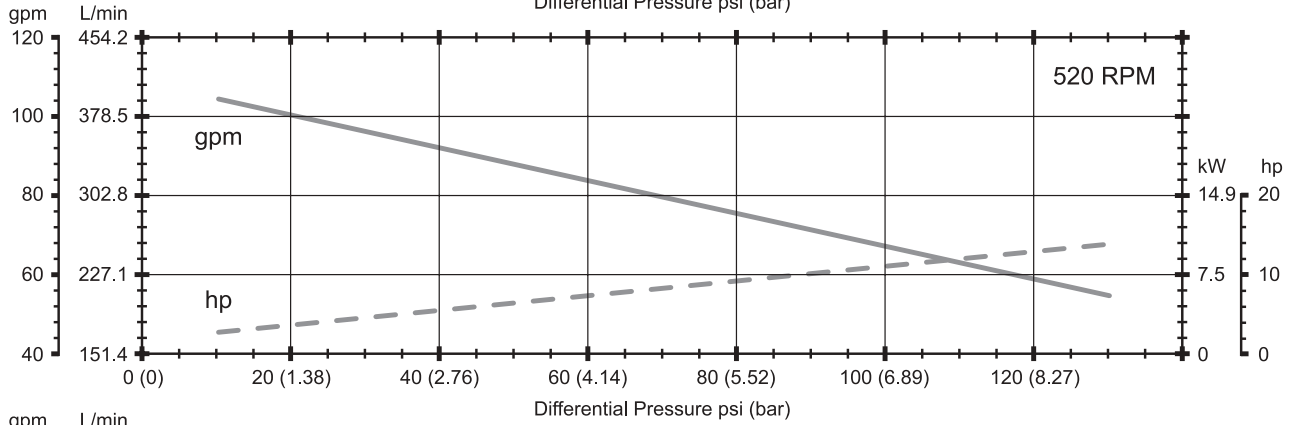
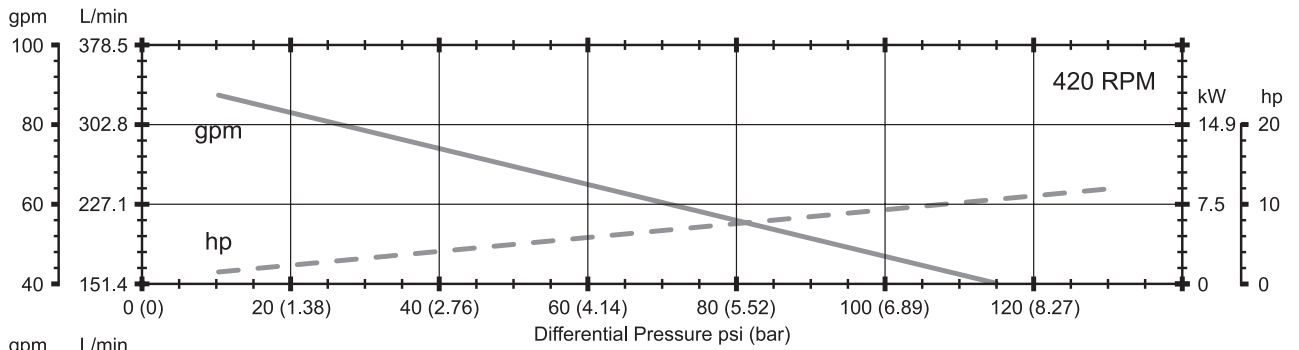

Appendix C—Performance Curves For Model 1521

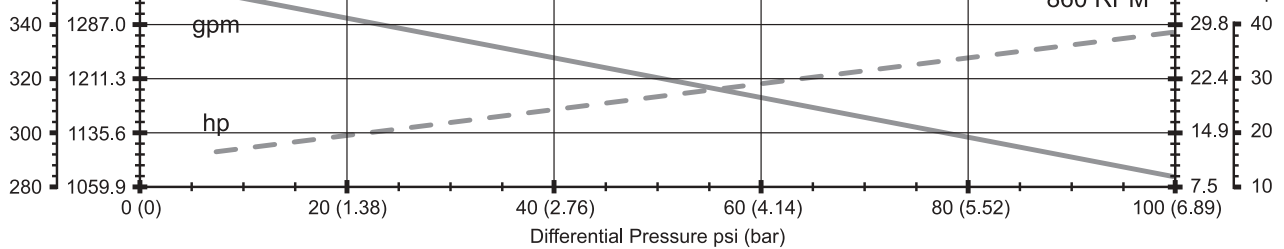
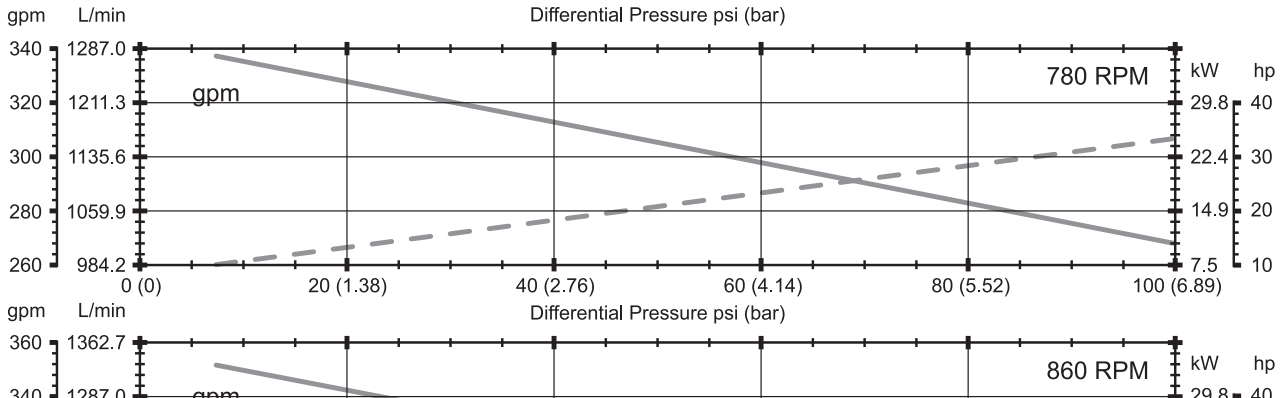
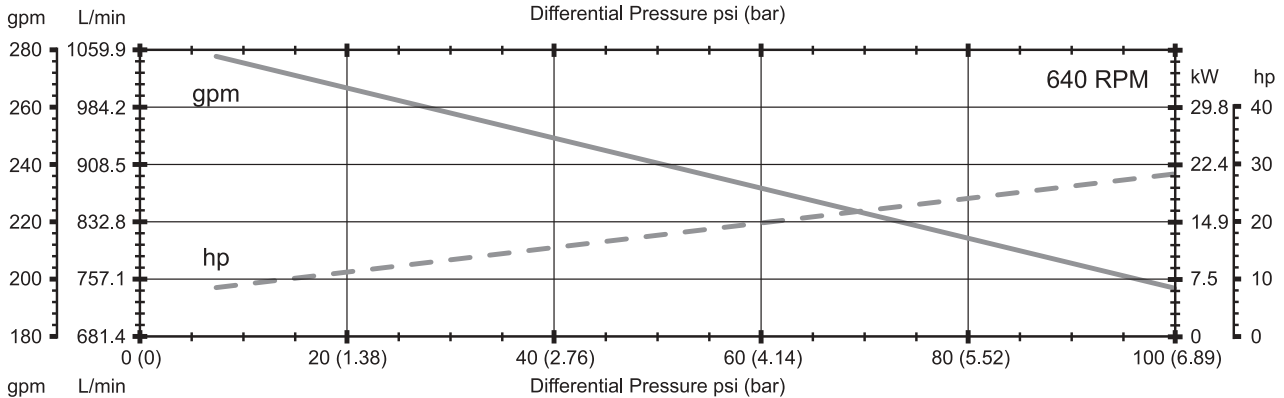
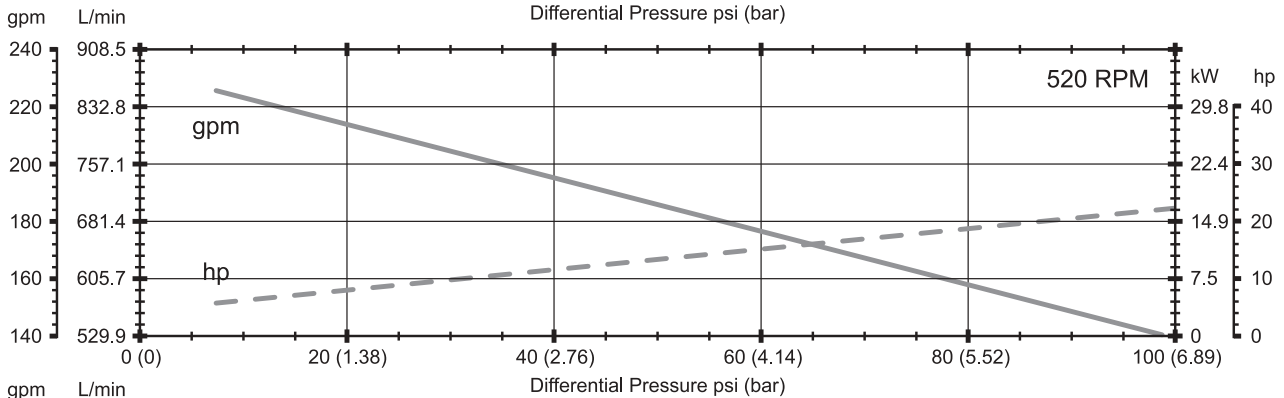
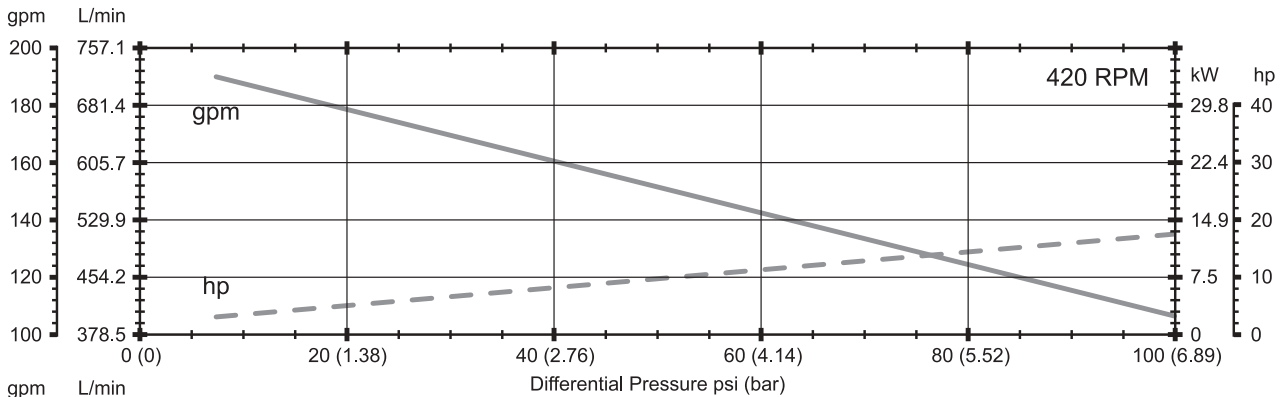

Appendix D—Outline Dimensions For Models C51 and F51

C51 Model

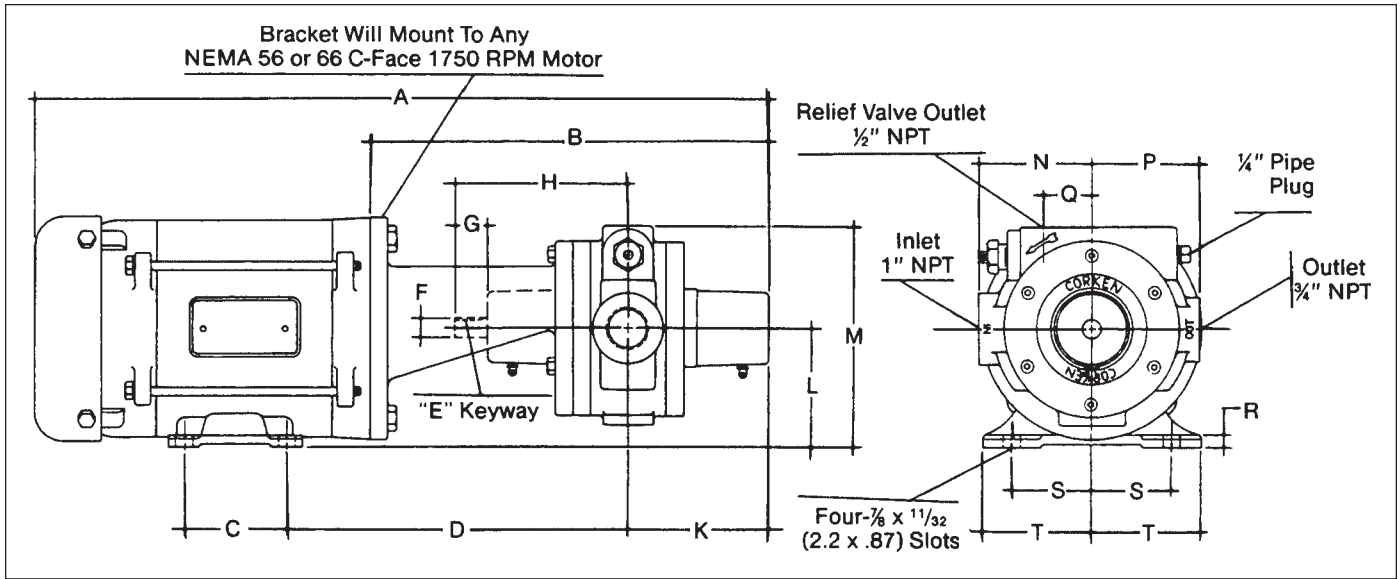

F51 Model

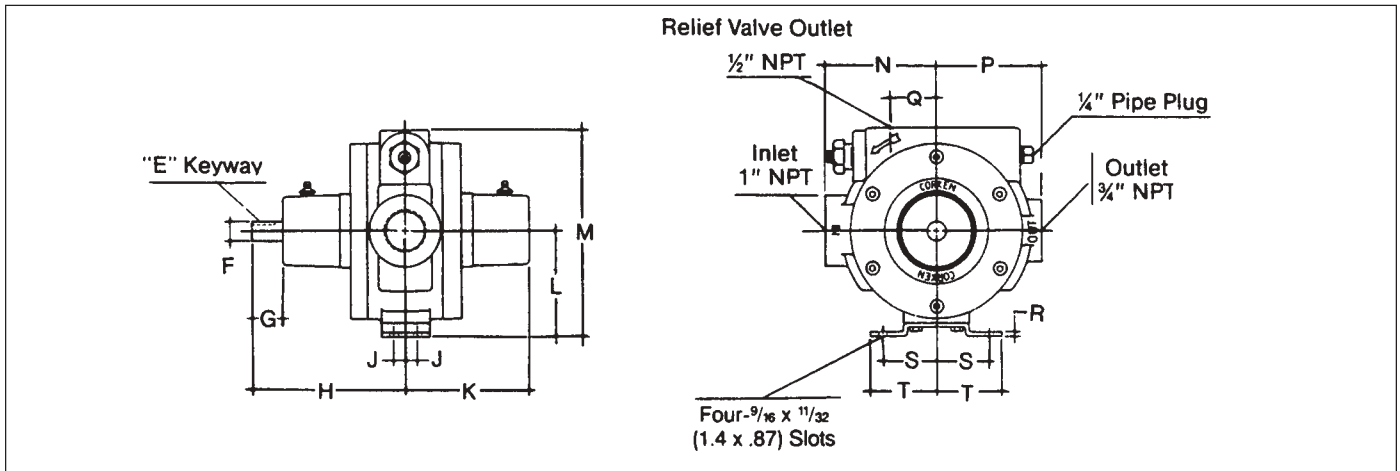

Outline Dimensions—Inches (Centimeters)

Model	A	B	C	D	E	F	G	H	J
C51	23 (58.4)	1-5/16 (28.7)	3 (7.62)	10-3/16 (25.9)	1/8 (0.32)	9/16 (1.43)	15/16 (2.38)	4-5/8 (11.7)	— —
F51	—	—	—	—	1/8 (0.32)	9/16 (1.43)	15/16 (2.38)	4-5/8 (11.7)	7/16 (1.10)

Model	K	L	M	N	P	Q	R	S	T
C51	3-11/16 (9.36)	3-1/2 (8.89)	6-1/2 (16.5)	3-3/8 (8.57)	3-3/16 (8.10)	1-7/8 (3.65)	7/32 (0.56)	2-7/16 (6.19)	3-1/4 (8.26)
F51	3-11/16 (9.36)	3-1/8 (7.93)	6-1/8 (15.6)	3-3/8 (8.57)	3-3/16 (8.10)	1-7/16 (3.65)	1/8 (0.32)	1-11/16 (4.29)	2 (5.08)

Appendix D—Outline Dimensions For Model F51-103

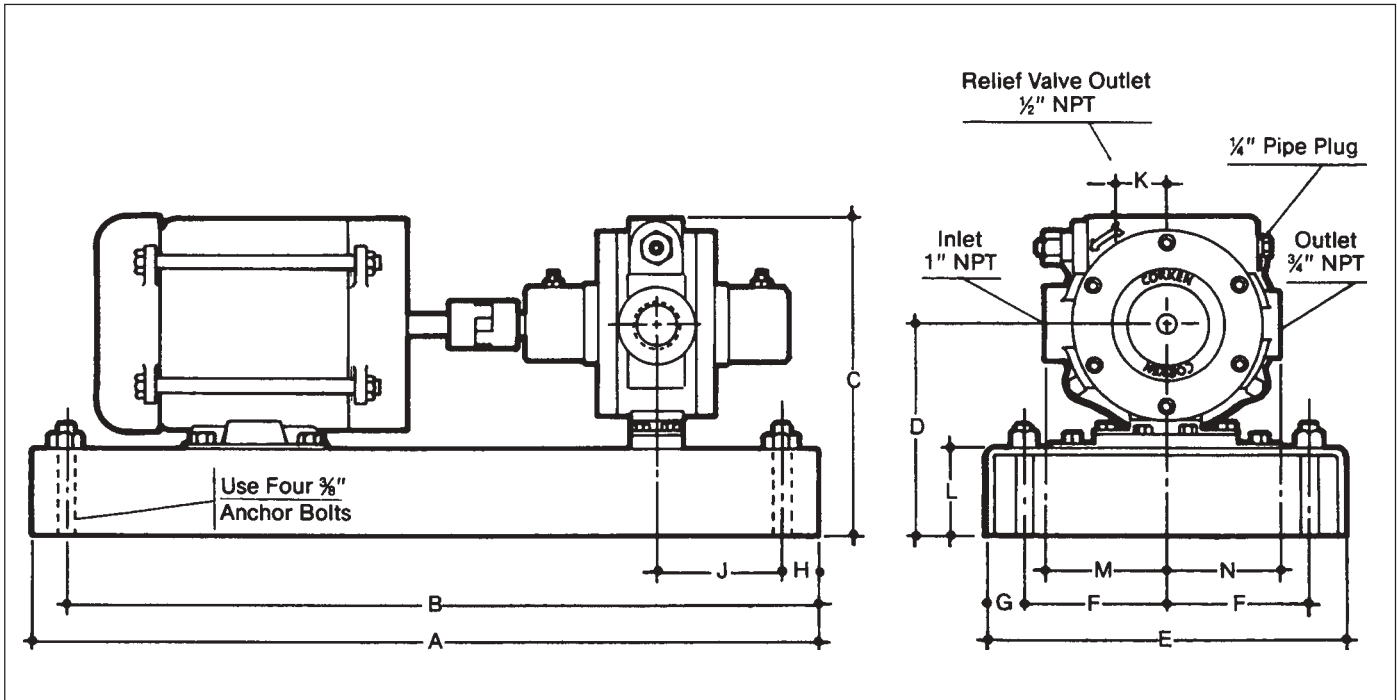

Outline Dimensions—Inches (Centimeters)													
Model	A	B	C	D	E	F	G	H	J	K	L	M	N
F51-101	22 (55.9)	20 (50.8)	9 (22.9)	6 (15.2)	10 (25.4)	4 (10.2)	1 (2.54)	1 (2.54)	3-1/2 (8.89)	1-7/16 (3.65)	2-1/2 (6.35)	3-3/8 (8.57)	3-3/16 (8.10)

Appendix D—Outline Dimensions For Models 521 and 1021

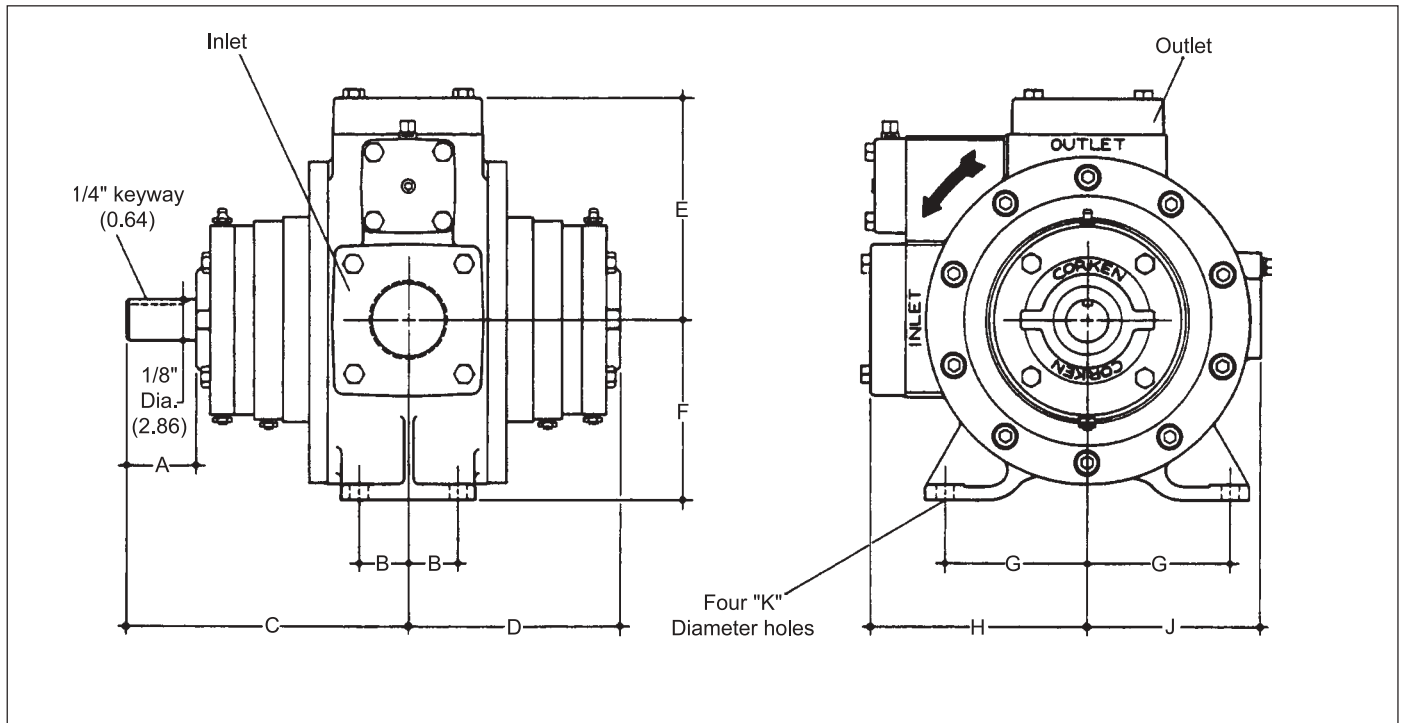

Outline Dimensions—Inches (Centimeters)

Model	Inlet	Outlet	A	B	C	D
521	2-1/2" NPT (std.) Opt: 2" NPT 2", 2-1/2" Weld	2" NPT (std.) Opt: 1-1/2", 2-1/2" NPT 1-1/2", 2", 2-1/2" Weld	1-31/32 (5)	1-3/8 (3.49)	7-7/8 (20)	5-29/32 (15)
1021	3" NPT (std.) Opt: 3", 4" Weld 4" NPT	3" NPT (std.) Opt: 3", 4" Weld 4" NPT	2 (5.08)	1-3/4 (4.45)	8-1/2 (21.59)	6-7/16 (16.35)

Outline Dimensions—Inches (Centimeters)

Model	E	F	G	H	J	K
521	6-1/8 (15.56)	5 (12.70)	4 (10.16)	6-1/8 (15.56)	4-11/16 (11.91)	1/2 (1.27)
1021	7-1/16 (17.94)	5-1/2 (13.97)	4 1/8 (10.48)	7-1/16 (17.94)	5-3/8 (13.65)	1/2 (1.27)

Appendix D—Outline Dimensions For Models F1021 and F1521

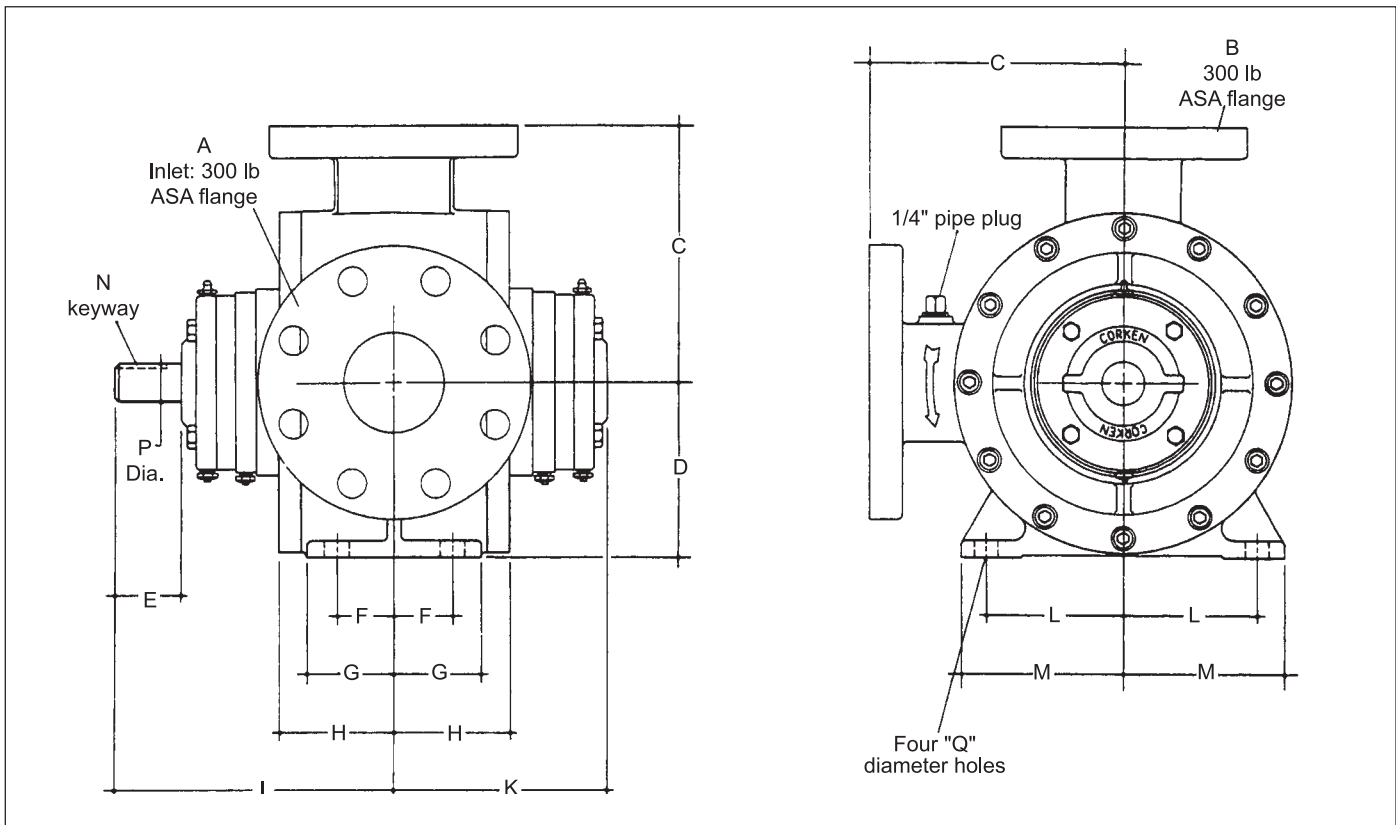

Outline Dimensions—Inches (Centimeters)

Model	A	B	C	D	E	F	G	H
F1021	3	2-1/2	7-3/4 (19.7)	5-1/2 (14.0)	2 (5.1)	1-3/4 (4.4)	2-5/8 (6.7)	3-1/2 (8.9)
F1521	4	3	7-27/32 (19.9)	5-1/2 (14.0)	3 (7.6)	2-7/8 (7.3)	3-3/4 (9.5)	4-5/8 (11.7)

Outline Dimensions—Inches (Centimeters)

Model	J	K	L	M	N	P	Q
F1021	8-1/2 (21.6)	6-1/2 (16.5)	4-1/8 (10.5)	4-15/16 (12.5)	1/4 (0.64)	1-1/8 (2.9)	1/2 (1.27)
F1521	10-5/8 (27.0)	8-1/16 (20.5)	4-1/8 (10.5)	4-15/16 (12.5)	1/4 (0.64)	1-1/8 (2.9)	1/2 (1.27)

Appendix D—Outline Dimensions For Models 521 and 1021-103

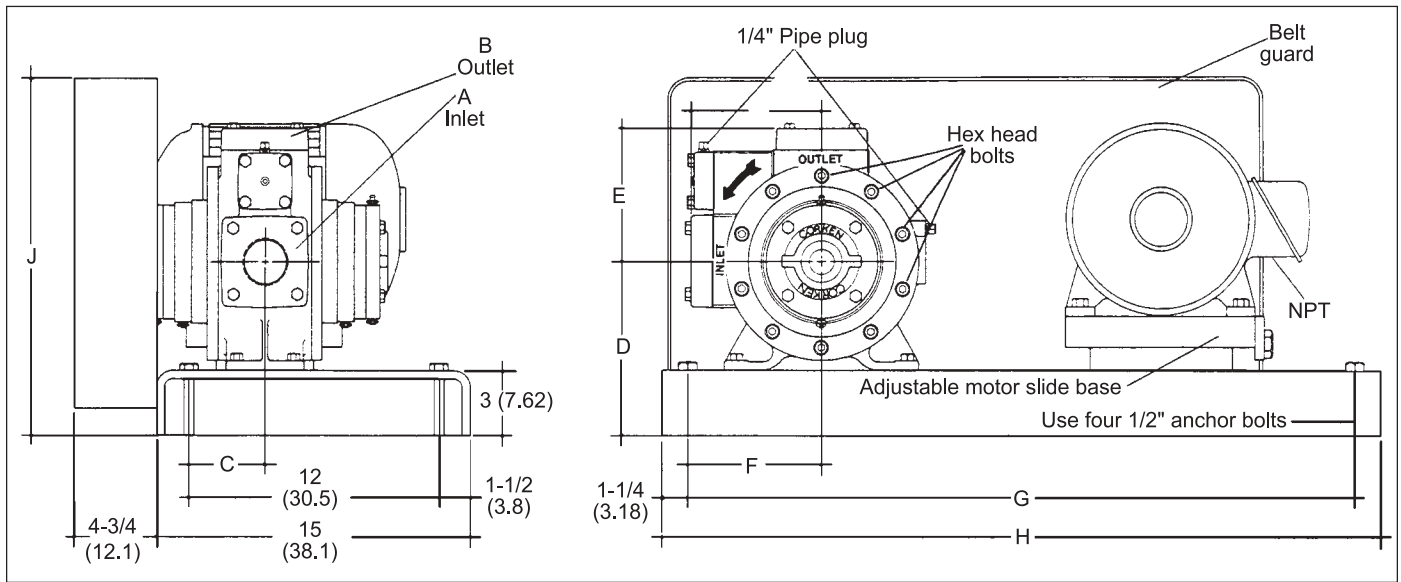

Flange Dimensions		
Model	A (inlet)	B (outlet)
521	2-1/2" NPT (2" NPT opt.)	2" NPT (1-1/2", 2-1/2" NPT opt.)
1021	3" NPT (4" NPT opt.)	3" NPT (4" NPT opt.)

Motor		Pump	521-103 Dimensions—Inches (Centimeters)						
Hp	Frame ¹	Speed	C	D	E	F	G	H	J
2	145T	All	3-5/8 (9.21)	8 (20.3)	6-1/8 (15.6)	6-1/4 (15.9)	31-1/2 (80.0)	34 (86.4)	16-1/2 (41.9)
2	182T	All	3-5/8 (9.21)	8 (20.3)	6-1/8 (15.6)	6-1/4 (15.9)	31-1/2 (80.0)	34 (86.4)	16-1/2 (41.9)
3	182T	All	3-5/8 (9.21)	8 (20.3)	6-1/8 (15.6)	6-1/4 (15.9)	31-1/2 (80.0)	34 (86.4)	16-1/2 (41.9)
3	184T	All	3-5/8 (9.21)	8 (20.3)	6-1/8 (15.6)	6-1/4 (15.9)	31-1/2 (80.0)	34 (86.4)	16-1/2 (41.9)
5	184T	All	3-5/8 (9.21)	8 (20.3)	6-1/8 (15.6)	6-1/4 (15.9)	31-1/2 (80.0)	34 (86.4)	16-1/2 (41.9)
7-1/2	213T	All	3-5/8 (9.21)	8 (20.3)	6-1/8 (15.6)	6-1/4 (15.9)	31-1/2 (80.0)	34 (86.4)	16-1/2 (41.9)
10	215T	420–470	3-5/8 (9.21)	10-3/4 (27.3)	6-1/8 (15.6)	9-1/4 (23.5)	39-1/2 (100.3)	42 (106.7)	19-3/4 (50.2)
10	215T	520–950	3-5/8 (9.21)	8 (20.3)	6-1/8 (15.6)	6-1/4 (15.9)	31-1/2 (80.0)	34 (86.4)	16-1/2 (41.9)

Motor		Pump	1021-103 Dimensions—Inches (Centimeters)						
Hp	Frame ¹	Speed	C	D	E	F	G	H	J
3	182T	All	4-1/2 (10.8)	8-1/2 (21.6)	7-3/16 (18.3)	6-1/4 (15.9)	31-1/2 (80.0)	34 (86.4)	16-1/2 (41.9)
3	182T	All	4-1/2 (10.8)	8-1/2 (21.6)	7-3/16 (18.3)	6-1/4 (15.9)	31-1/2 (80.0)	34 (86.4)	16-1/2 (41.9)
5	184T	All	4-1/2 (10.8)	8-1/2 (21.6)	7-3/16 (18.3)	6-1/4 (15.9)	31-1/2 (80.0)	34 (86.4)	16-1/2 (41.9)
7-1/2	213T	All	4-1/2 (10.8)	8-1/2 (21.6)	7-3/16 (18.3)	6-1/4 (15.9)	31-1/2 (80.0)	34 (86.4)	16-1/2 (41.9)
10	215T	420–470	4-1/2 (10.8)	10-1/2 (26.7)	7-3/16 (18.3)	9-1/4 (23.5)	39-1/2 (100.3)	42 (106.7)	19-3/4 (50.2)
10	215T	520–950	4-1/2 (10.8)	8-1/2 (21.6)	7-3/16 (18.3)	6-1/4 (15.9)	31-1/2 (80.0)	34 (86.4)	16-1/2 (41.9)
15	254T	420–520	4-1/2 (10.8)	10-1/2 (26.7)	7-3/16 (18.3)	9-1/4 (23.5)	39-1/2 (100.3)	42 (106.7)	19-3/4 (50.2)
15	254T	580–950	4-1/2 (10.8)	8-1/2 (21.6)	7-3/16 (18.3)	6-1/4 (15.9)	31-1/2 (80.0)	34 (86.4)	16-1/2 (41.9)
20	256T	520	4-1/2 (10.8)	10-1/2 (26.7)	7-3/16 (18.3)	9-1/4 (23.5)	39-1/2 (100.3)	42 (106.7)	19-3/4 (50.2)
20	256T	640–950	4-1/2 (10.8)	8-1/2 (21.6)	7-3/16 (18.3)	6-1/4 (15.9)	31-1/2 (80.0)	34 (86.4)	16-1/2 (41.9)

¹All dimensions based on a motor speed of 1,750 RPM.

Appendix D—Outline Dimensions For Models F1021 and F1521-103

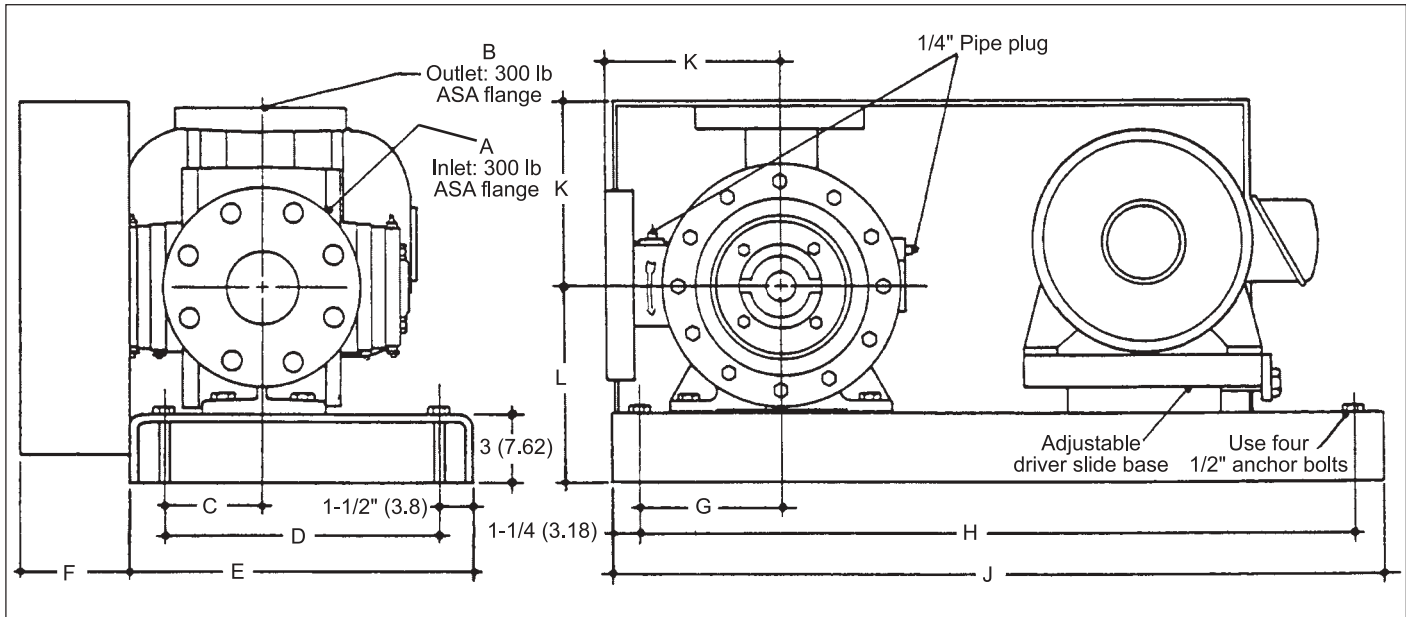

Flange Dimensions		
Model	A (inlet)	B (Outlet)
F1021	3" 300# ANSI	2-1/2" 300# ANSI
F1521	4" 300# ANSI	3" 300# ANSI

Motor		Pump	F1021 Outline Dimensions—Inches (Centimeters)								
Hp	Frame ¹	Speed	C	D	E	F	G	H	J	K	L
3	182T	All	4-1/4 (10.8)	12 (30.5)	15 (38.1)	5 (12.7)	6-1/4 (15.9)	31-1/2 (80)	34 (86.4)	7-3/4 (19.7)	8-1/2 (21.6)
3	182T	All	4-1/4 (10.8)	12 (30.5)	15 (38.1)	5 (12.7)	6-1/4 (15.9)	31-1/2 (80)	34 (86.4)	7-3/4 (19.7)	8-1/2 (21.6)
5	184T	All	4-1/4 (10.8)	12 (30.5)	15 (38.1)	5 (12.7)	6-1/4 (15.9)	31-1/2 (80)	34 (86.4)	7-3/4 (19.7)	8-1/2 (21.6)
7-1/2	213T	All	4-1/4 (10.8)	12 (30.5)	15 (38.1)	5 (12.7)	6-1/4 (15.9)	31-1/2 (80)	34 (86.4)	7-3/4 (19.7)	8-1/2 (21.6)
10	215T	420–470	4-1/4 (10.8)	12 (30.5)	15 (38.1)	5 (12.7)	9-1/4 (23.5)	39-1/2 (100.3)	42 (106.7)	7-3/4 (19.7)	10-1/2 (26.7)
10	215T	520–950	4-1/4 (10.8)	12 (30.5)	15 (38.1)	5 (12.7)	6-1/4 (15.9)	31-1/2 (80)	34 (86.4)	7-3/4 (19.7)	8-1/2 (21.6)
15	254T	420–520	4-1/4 (10.8)	12 (30.5)	15 (38.1)	5 (12.7)	9-1/4 (23.5)	39-1/2 (100.3)	42 (106.7)	7-3/4 (19.7)	10-1/2 (26.7)
15	254T	580–950	4-1/4 (10.8)	12 (30.5)	15 (38.1)	5 (12.7)	6-1/4 (15.9)	31-1/2 (80)	34 (86.4)	7-3/4 (19.7)	8-1/2 (21.6)
20	256T	520	4-1/4 (10.8)	12 (30.5)	15 (38.1)	5 (12.7)	9-1/4 (23.5)	39-1/2 (100.3)	42 (106.7)	7-3/4 (19.7)	10-1/2 (26.7)
20	256T	640–950	4-1/4 (10.8)	12 (30.5)	15 (38.1)	5 (12.7)	6-1/4 (15.9)	31-1/2 (80)	34 (86.4)	7-3/4 (19.7)	8-1/2 (21.6)

Motor		Pump	F1521 Outline Dimensions—Inches (Centimeters)								
Hp	Frame ¹	Speed	C	D	E	F	G	H	J	K	L
5	184T	All	6-3/8 (16.2)	12 (30.5)	15 (38.1)	5 (12.7)	6-1/4 (15.9)	31-1/2 (80)	34 (86.4)	7-7/8 (19.9)	8-1/2 (21.6)
7-1/2	213T	All	6-3/8 (16.2)	12 (30.5)	15 (38.1)	5 (12.7)	6-1/4 (15.9)	31-1/2 (80)	34 (86.4)	7-7/8 (19.9)	8-1/2 (21.6)
10	215T	420–470	6-3/8 (16.2)	12 (30.5)	15 (38.1)	5 (12.7)	9-1/4 (23.5)	39-1/2 (100.3)	42 (106.7)	7-7/8 (19.9)	10-1/2 (26.7)
10	215T	520–860	6-3/8 (16.2)	12 (30.5)	15 (38.1)	5 (12.7)	6-1/4 (15.9)	31-1/2 (80)	34 (86.4)	7-7/8 (19.9)	8-1/2 (21.6)
15	254T	420–520	6-3/8 (16.2)	12 (30.5)	15 (38.1)	5 (12.7)	9-1/4 (23.5)	39-1/2 (100.3)	42 (106.7)	7-7/8 (19.9)	10-1/2 (26.7)
15	254T	580–860	6-3/8 (16.2)	12 (30.5)	15 (38.1)	5 (12.7)	6-1/4 (15.9)	31-1/2 (80)	34 (86.4)	7-7/8 (19.9)	8-1/2 (21.6)
20	256T	520	6-3/8 (16.2)	12 (30.5)	15 (38.1)	5 (12.7)	9-1/4 (23.5)	39-1/2 (100.3)	42 (106.7)	7-7/8 (19.9)	10-1/2 (26.7)
20	256T	640–860	6-3/8 (16.2)	12 (30.5)	15 (38.1)	5 (12.7)	6-1/4 (15.9)	31-1/2 (80)	34 (86.4)	7-7/8 (19.9)	8-1/2 (21.6)

¹All dimensions based on a motor speed of 1,750 RPM.

Appendix E—V-Belt Selection For Stationary Coro-Vane® Pumps

1,450 RPM Motor			Motor Hp	Nominal Pump RPM	1,750 RPM Motor		
Belt Number	Sheave Pitch Diameter				Sheave Pitch Diameter		Belt Number
	Pump	Motor			Pump	Motor	
B64	B15.4	B7.4	2	420	1-3V14.0	1-3V3.35	3V600
B60	B13.6	B4.2		470	1-3V10.6	1-3V2.80	3V530
B60	B12.4	B4.2		520	1-3V10.6	1-3V3.15	3V530
B55	B11.0	B4.2		580	1-3V10.6	1-3V3.65	3V560
B56	B11.0	B4.8		640	1-3V8.0	1-3V3.00	3V500
B64	B15.4	B4.4	3	420	2-3V10.6	2-3V2.65	3V530
B64	B15.4	B4.8		470	2-3V10.6	2-3V2.80	3V530
A55	2A10.6	2A3.6		520	1-3V14.0	1-3V4.12	3V630
B55	2B11.0	2B4.2		580	1-3V14.0	1-3V4.75	3V630
B60	B12.4	B5.4		640	2-3V8.0	2-3V3.00	3V500
B56	B11.0	B5.2		710	2-3V6.9	2-3V2.80	3V475
B53	B9.4	B4.8		780	1-3V8.0	1-3V3.65	3V500
B53	B8.6	B5.0		860	2-3V5.3	2-3V2.65	3V450
B51	B7.4	B4.8		950	1-3V6.5	1-3V3.65	3V475
B64	2B15.4	2B4.4		5	420	3-A13.2	3-A3.2
B60	2B13.6	2B4.2	470		2-A13.2	2-A3.6	A60
B60	2B12.4	2B4.2	520		2-A12.0	2-A3.6	A56
B55	2B11.0	2B4.2	580		2-3V10.6	2-3V3.65	3V560
B56	2B11.0	2B4.8	640		3-3V8.0	3-3V3.00	3V500
B56	2B11.0	2B5.2	710		2-3V8.0	2-3V3.35	3V500
B53	2B9.4	2B4.8	780		2-3V6.9	2-3V3.15	3V475
B53	2B8.6	2B5.0	860		2-3V6.5	2-3V3.15	3V475
B51	2B7.4	2B4.8	950		2-3V6.0	2-3V3.35	3V475
B64	3B15.4	3B4.4	7-1/2		420	4-A13.2	4-A3.2
B64	2B15.4	2B4.8		470	3-A13.2	3-A3.6	A60
B60	3B12.7	3B4.2		520	3-3V14.0	3-3V4.12	3V630
B55	3B11.0	3B4.2		580	2-3V14.0	2-3V4.75	3V630
B56	3B11.0	3B4.8		640	2-3V14.0	2-3V5.30	3V630
B56	3B11.0	3B5.2		710	2-3V10.6	2-3V4.50	3V560
B53	3B9.4	3B4.8		780	3-3V6.9	3-3V3.15	3V475
B53	3B8.6	3B5.0		860	3-3V6.5	3-3V3.15	3V475
B51	3B7.4	3B4.8		950	2-3V8.0	2-3V4.50	3V530
B71	3B18.4	3B5.2		10	420	3-3V19.0	3-3V4.50
B71	2B18.4	2B5.8	470		3-3V19.0	3-3V5.00	3V710
B60	4B12.4	4B4.2	520		3-3V14.0	3-3V4.12	3V630
B55	4B11.0	4B4.2	580		3-3V14.0	3-3V4.50	3V630
B56	4B11.0	4B4.8	640		2-3V14.0	2-3V5.30	3V630
B62	3B12.4	3B5.8	710		2-3V14.0	2-3V5.60	3V630
B56	3B11.0	3B5.8	780		2-B12.4	2-B5.6	B60
B62	3B12.4	3B7.0	860		2-3V10.6	2-3V5.30	3V560
B60	3B9.4	3B6.0	950		2-3V10.6	2-3V5.60	3V560
B71	4B18.4	4B5.2	15		420	4-3V19.0	4-3V4.75
B71	3B18.4	3B5.8		470	4-3V19.0	4-3V5.00	3V710
B62	5B13.6	5B4.8		520	3-3V19.0	3-3V5.60	3V750
B60	5B12.4	5B4.8		580	4-3V14.0	4-3V4.75	3V630
B56	5B11.0	5B4.8		640	3-3V14.0	3-3V5.30	3V630
B56	5B11.0	5B5.2		710	3-3V14.0	3-3V5.60	3V630
B53	5B9.4	5B4.8		780	3-B12.4	3-B5.6	B60
B53	5B8.6	5B5.0		860	2-B12.4	2-B6.0	B60
B51	5B7.4	5B4.8		950	2-B11.0	2-B6.0	B56
B75	4B18.4	4B6.6		20	520	4-3V19.0	4-3V5.60
B68	4B15.4	4B6.8	640		4-3V14.0	4-3V5.30	3V630
B64	4B12.4	4B6.6	780		3-B13.6	3-B6.0	B62
B68	3B13.6	3B8.0	860		4-3V10.6	4-3V5.30	3V560
B65	3B12.4	3B8.0	950		3-B11.0	3-B6.0	B56

Do not use a V-belt drive system on a Coro-Vane® pump with a driver greater than 25 horsepower. Consult factory if your application is outside this parameter.

Appendix F—Troubleshooting Guide

In diagnosing pump and system troubles, record the following data during product transfers:

1. Pressure at pump suction.
2. Pressure at pump discharge.
3. Pressure in truck tank.
4. Pressure in tank being filled.
5. Pipe size and length of suction and discharge lines.
6. Size and length of vapor equalizing line.
7. Pump speed if practical.

Problem	Cause	Solution
Low capacity	Pump speed too slow	Check engine speed and PTO ratio. Consult pump performance curve. Use tachometer on pump if speed is questionable.
	High differential pressure	Restriction in discharge piping or hose too small. Vapor equalization lines too small or not used.
	External bypass valve stuck open or set too low	Readjust, repair, or replace valve.
	Clogged strainer	Clean strainer.
	Suction pipe too small or restricted	Indicated by pump inlet pressure dropping several pounds when pump is started. Remove restriction or modify piping.
	Worn vanes	Replace.
	Pump without vapor return	Without vapor equalization, a pump can remove only about 3% of the truck tank capacity per minute without severe cavitation and capacity loss.
	Worn sideplates	Reverse or replace sideplates. Check universal drive assembly to make sure angularity is within limits, yokes are parallel and slip-joint is greased. Check bearings.
	Vanes sticking	Remove vanes and clean out foreign matter (check strainer). Replace vanes if swollen.
Pump runs but no flow	Valve closed	Check valves. Make sure internal tank excess flow valve is open! Refer to manufacturer's instructions.
	Excess flow valve slugged	Stop pump until valve opens. If problem continues, slow pump down or install a new or larger excess flow valve.
	Broken shaft	Disassemble and inspect pump. Repair if necessary.
	Defective meter	Service meter.
Pump will not turn—locked up	Foreign matter in pump	Clean out the pump—check strainer in suction line.
	Vanes broken	Clean out pump carefully and replace vanes. Has pump been operated dry? Then, check for damage to cam and rotor shaft assembly.
	Bearing seized	Replace pump bearings. Grease monthly. Use ball bearing grease manufactured for intended service.
	Moisture frozen in pump	Let thaw and break loose carefully. Add alcohol to tank (on LP-Gas). Check with product supplier about possibility of water in gas.
Will not build pressure	Poor suction conditions	Clean inlet strainer. Increase pipe size.
	External bypass valve set too low	Set valve for higher pressure—see instructions.
	Worn vanes and/or sideplates	Disassemble, inspect and repair as necessary. Do not run pump dry!

Appendix F—Troubleshooting Guide (continued)

Pump is noisy	Cavitation from poor suction conditions	As above.
	Vanes sticking	As above.
	Bearings worn	Replace if necessary—grease monthly.
	Very high differential pressure	Check for restriction in discharge line. Delivery hose too small and too long. Slow down pump!
		Check vapor release float assembly on meter and meter differential valve.
PTO shaft vibration	Inspect and repair driveline component.	
Pump leaks around shaft	Seal or O-rings failed	Inspect seal assembly and replace if necessary. Keep new seal very clean when replacing seal. Recommend a light oil film on O-rings. Do not run pump dry!

Appendix G—Storage of the Stationary Coro-Vane® Pumps

If your Corken Coro-Vane® pump is to be removed from service for some time, the pump must be protected as propane, butane and anhydrous ammonia all leave the metal "bare" and open to corrosion. Piping and tanks not in service should also be protected, as the rust particles can destroy the pump's seals almost immediately after startup.

1. Fill or thoroughly flush the pump with a light rust inhibiting oil. (If the pump is flushed with oil, placing some desiccant packets inside the pump will provide added protection.)
2. Plug all pump openings.
3. Store in a dry location.
4. Before placing the pump back into service, drain the oil and remove any desiccant packets.
5. Refer to the "Operation of Your Coro-Vane® Pump" on page 6 of this Installation, Operation and Maintenance (IOM) manual.

Solutions beyond products...

CORKEN[®]
IDEX

Corken, Inc. • A Unit of IDEX Corporation
P.O. Box 12338, Oklahoma City, OK 73157 U.S.A.
3805 N.W. 36th St., Oklahoma City, OK 73112
Phone (405) 946-5576 • Fax (405) 948-7343
Visit our website at <http://www.corken.com>
or e-mail us at info.corken@idexcorp.com