

# Appendix E—Outline Dimensions

Model 91–691 with -109 or -109A Mounting (model -109A shown below)

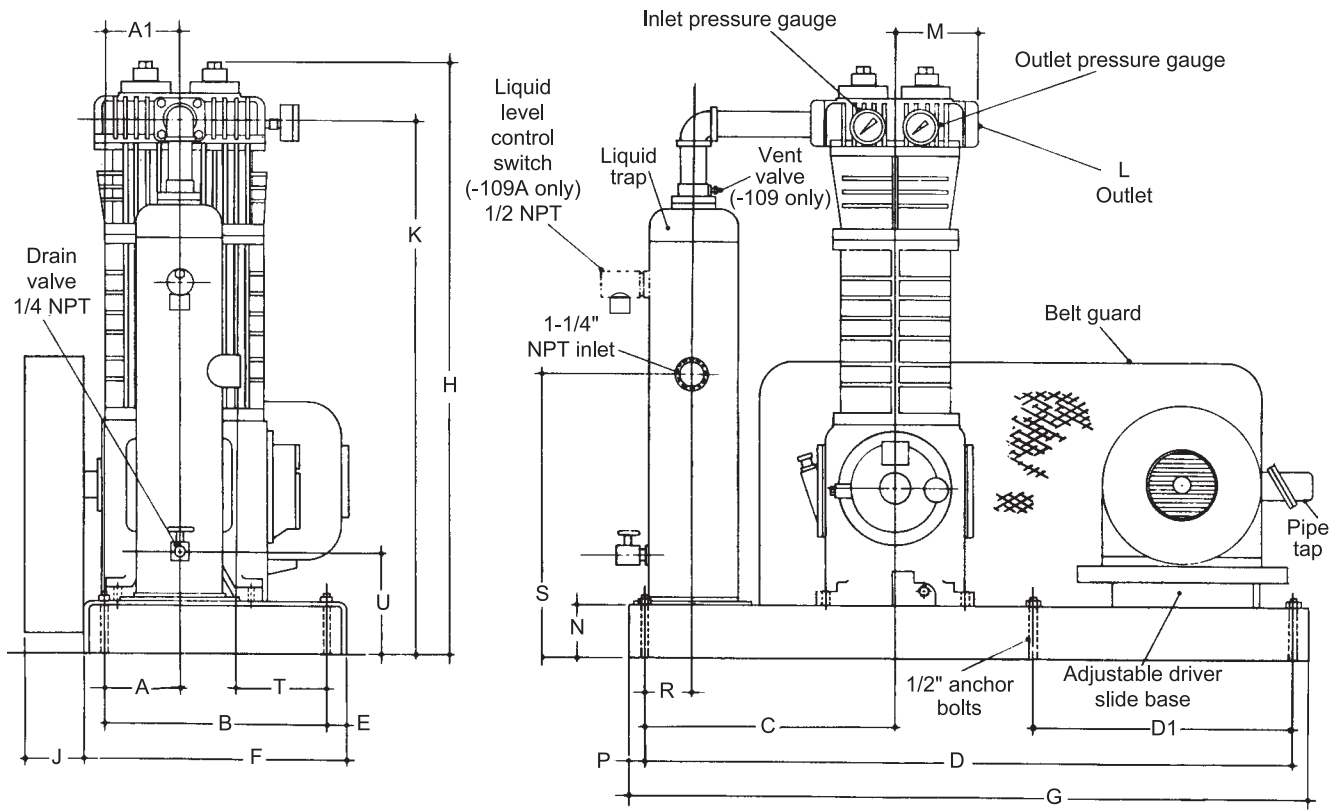

| Outline Dimensions—Inches (Centimeters) |                 |                 |              |                   |                   |                  |                |              |               |                    |                 |
|---|-----------------|-----------------|--------------|-------------------|-------------------|------------------|----------------|--------------|---------------|--------------------|-----------------|
| Model                                   | A               | A1              | B            | C                 | D                 | D1               | E              | F            | G             | H                  | J               |
| 91-109, -109A                           | 1-3/16<br>(3.7) | 5-1/4<br>(13.4) | 12<br>(30.5) | 13-5/16<br>(33.8) | 31-1/2<br>(80.0)  | —                | 1-1/2<br>(3.8) | 15<br>(38.1) | 34<br>(86.4)  | 31-3/16<br>(79.2)  | 5-1/4<br>(13.3) |
| 291-109, -109A                          | 5<br>(12.7)     | —               | 12<br>(30.5) | 15-3/4<br>(40.0)  | 39-1/2<br>(100.3) | —                | 1-1/2<br>(3.8) | 15<br>(38.1) | 42<br>(106.7) | 30-7/8<br>(78.4)   | 5-1/4<br>(13.3) |
| 491-109, -109A                          | 5-3/4<br>(14.6) | —               | 15<br>(38.1) | 18<br>(45.7)      | 45-1/2<br>(115.6) | —                | 1-1/2<br>(3.8) | 18<br>(45.7) | 48<br>(121.9) | 33-3/4<br>(85.7)   | 5-1/4<br>(13.3) |
| 691-109, -109A                          | 8-1/4<br>(30.0) | —               | 17<br>(43.2) | 19-1/4<br>(48.8)  | 49-1/2<br>(125.7) | 19-3/4<br>(50.1) | 1-1/2<br>(3.8) | 20<br>(50.8) | 52<br>(132)   | 43-3/16<br>(109.6) | 5-1/2<br>(14.0) |

| Outline Dimensions—Inches (Centimeters) |                   |              |                  |             |                |                 |                   |                 |                 |  |
|---|-------------------|--------------|------------------|-------------|----------------|-----------------|-------------------|-----------------|-----------------|--|
| Model                                   | K                 | L            | M                | N           | P              | R               | S                 | T               | U               |  |
| 91-109, -109A                           | 28-3/16<br>(71.6) | 3/4<br>NPT   | 2-5/16<br>(5.9)  | 3<br>(7.6)  | 1-1/4<br>(3.2) | 3-5/8<br>(9.2)  | 9-1/2<br>(24.1)   | 2-3/4<br>(6.9)  | 6-3/4<br>(17.1) |  |
| 291-109, -109A                          | 28-1/2<br>(72.4)  | 3/4<br>NPT   | 2-11/16<br>(6.8) | 3<br>(7.6)  | 1-1/4<br>(3.2) | 3-7/8<br>(9.9)  | 9-1/2<br>(24.1)   | 4-1/2<br>(11.4) | 6-3/4<br>(17.1) |  |
| 491-109, -109A                          | 30-1/8<br>(76.5)  | 1-1/4<br>NPT | 4<br>(10.2)      | 4<br>(10.2) | 1-1/4<br>(3.2) | 4<br>(10.2)     | 10-1/2<br>(26.7)  | 5.25<br>(13.3)  | 7-3/4<br>(19.7) |  |
| 691-109, -109A                          | 39-1/8<br>(99.3)  | 1-1/2<br>NPT | 6-3/8<br>(16.1)  | 4<br>(10.2) | 1-1/4<br>(3.2) | 4-1/8<br>(10.4) | 21-7/16<br>(54.4) | 7-1/4<br>(18.4) | 7-3/4<br>(19.7) |  |