

KEEP THIS DOCUMENT WITH THE PRODUCT UNTIL IT REACHES THE END USER.

WARNING

CAUTION: Contact with or inhalation of Liquid Anhydrous Ammonia or LP-Gas or their vapors can cause serious injury or death. Dispersment must be in accordance with local regulations. For the proper handling and storage of Anhydrous Ammonia refer to ANSI Standard K61.1. For the proper handling and storage of Liquefied Petroleum Gas refer to NFPA Pamphlet 58.

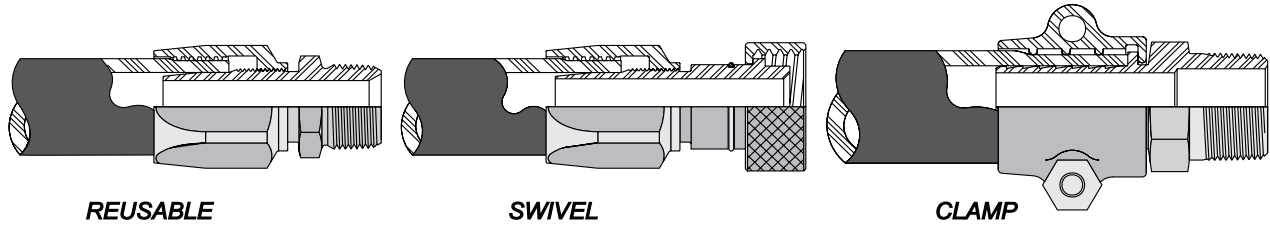

TOOLS REQUIRED: A Bench Vise, Mandrel Assembly Tool, Hose Cutter, and Hose Lubricant.

THE FOLLOWING INSTRUCTIONS APPLY TO ALL SWIVEL, REUSABLE, AND CLAMP HOSE COUPLINGS:

IMPORTANT: Please read all instructions carefully before attempting assembly. Install, use, and maintain per all applicable federal, state, local laws and codes, and NFPA Pamphlet 58.

Step 1: Only use Hoses that are specifically labeled for the intended service. The hose must have dimensions and tolerances as the Rubber Manufacturers Association specifies, i.e., 350 psig for LP-Gas or NH₃ hose.

Step 2: Cut the hose end square to the hose length.

NOTE: Steps three (3) thru six (6) are for Swivel and Reusable hose couplings only.

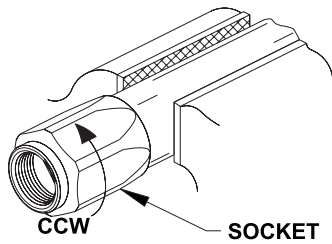

FIG. 1

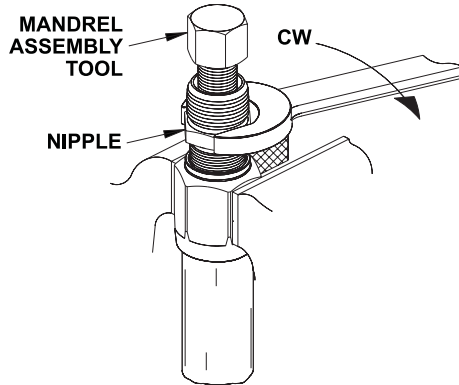

FIG. 2

Step 3: Lubricate the interior surface of the Socket. Place the Hose in a Bench Vise (See Fig. 1). Place the Socket over the Hose and turn counterclockwise (CCW) until Hose is within 1/8" of the inside Socket shoulder.

NOTE: If visual inspection of the Hose End relative to the inside Socket shoulder is difficult, place a mark on the Hose equal to the depth of the recess in the Socket. Screw the Socket (CCW) onto the Hose within 1/8" of this mark.

Step 4: A Mandrel Assembly Tool (available from Aeroquip or Weatherhead) is recommended to complete the assembly.

Step 5: Use a suitable hose lubricant on the Nipple threads, inside the hose and on the Mandrel Assembly Tool.

Step 6: Insert the Assembly Tool into the Nipple, (See Fig. 2), and screw the nipple clockwise (CW) into the Socket until the shoulder of the Nipple touches the end of the Socket.

The Swivel and Reusable Hose Coupling Assemblies are completed.

NOTE: Steps seven (7) and eight (8) are for Clamp Hose Couplings only.

Step 7: Screw the Nipple into the hose up to the Nipple Groove. Make sure the two Clamp portions fit together into the Nipple groove.

Step 8: Install Clamp bolts and tighten securely.

NOTE: If the two halves of the Clamp come in contact with each other, it indicates the hose outside diameter is undersize or the inside diameter is oversize.

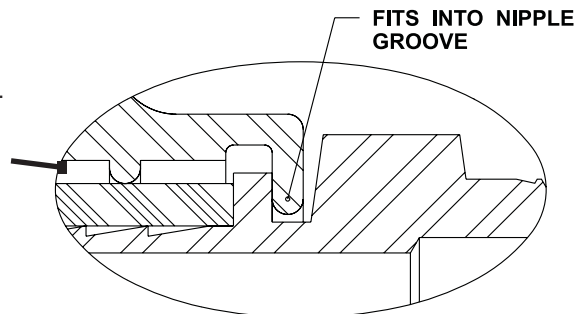

The Clamp Hose Coupling Assembly is complete.