

Complying With NFPA 58 Transfer Area and Bulk Plant Liquid Opening Requirements



Table of Contents

Table of Contents 2

Transfer Area Valves and Bulkheads 3

 Emergency Shutoff Valves 3

 Bobtail and Transport Transfer 3

 Cable Closure 4

 Pneumatic Closure 4

 ESVs for Tank Cars 4

 Back Checks and Internal Valves 5

 Bulkheads 5

Valves For Bulk Plant and Industrial Plant Container Liquid Openings 6

 Internal Valves In New Installations 6

 Back Check Valves In New Installations 7

 Retrofit of Existing Storage Containers by July 1, 2011 7

 What about Vapor Openings 7

 Internal Valve Actuation Methods 8

 Signage and Remote Closure Locations for All Installations 11

 Operational Issues with Internal Valves 11

 Conclusion 12

This bulletin discusses how Fisher valves and accessory equipment can be used to satisfy NFPA 58 requirements regarding the transfer area at LP-gas bulk plants and the installation of internal valves or the retrofit of 4000 gallon (15 142 l) or larger storage containers with internal valves, emergency shutoff valves and back check valves. For Transfer Areas, it brings out the advantages and disadvantages of certain hook-ups and bulkhead installation considerations. For 4000 Gallon (15 142 l) and larger bulk plant or industrial plant containers, it describes which valves can be used, where retrofit valves must be placed, and signage requirements. For complete information and specifications on specific valves mentioned here, refer to Fisher's "Transfer Area Valves and Valves for Bulk Storage Liquid Openings" product sheet.

Transfer Area Valves and Bulkheads

Emergency Shutoff Valves

Emergency Shutoff Valves (ESVs) were first mandated in the 1976 edition of NFPA 58. The following three features must be incorporated in an ESV (Ref. NFPA 58, §5.10.4)

- Automatic shutoff through thermal actuation. The thermal element must melt at no more than 250°F (121°C).
- Manual shutoff from a remote location
- Manual shutoff at the installed location.

The following installation points must be followed for the installation to comply with NFPA 58 requirements.

- An ESV is required on liquid transfer lines 1 1/2-inch (38,1 mm) or larger and on vapor lines 1 1/4-inch (31,8 mm) and larger.
- A back check valve, designed specifically for the application, may be used if flow is in one direction only.
- The thermal element for the ESV must be no more than 5 feet (1,5 m) from the nearest end of the hose or swivel piping connected to the piping on which the ESV is installed.
- The ESV or back check valve must be installed within 20 feet (6,1 m) of lineal piping from the nearest hose or swivel piping connection.
- The ESV or back check must be installed in the plant piping so that any break will occur on the swivel piping or hose side of the connection while leaving the valves and piping intact on the plant side of the piping. This protection can be

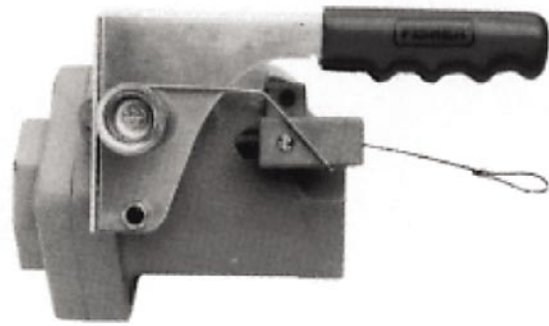

Figure 1. Type N550 Snappy Joe® ESV

accomplished by the use of concrete bulkheads or equivalent anchorage or by the use of a weakness or shear fitting.

- Remote location shutoff devices must be located not less than 25 feet (7,6 m) or more than 100 feet (30,5 m) in the path of egress from the ESV.

An ESV gives a way of remotely shutting off gas from the stationary storage piping. Primarily there are two situations which could create a need for remote ESV closure:

- (1) A pull-away by a bobtail or transport truck with the hose/piping still connected, or
- (2) A hose rupture or piping break.

If either of these things took place at a bulk plant without ESV protection, it might be impossible to reach the shutoff valve at the tank in order to shutdown the system.

Remember that NFPA 58 calls for ESV protection on both sides of the transfer hose or piping. Bobtails and transports equipped with remotely closed internal valves can give protection to the truck side of the hose.

Bobtail and Transport Transfer

Fisher's Type N550 Snappy Joe® ESVs are designed to protect the bulk plant side of the installation when loading or unloading bobtails and transports. All Type N550 Snappy Joes® look and operate exactly the same; the only difference in the 1-1/4, 2, and 3-inch FNPT units is their physical size. This can make training drivers to use the Snappy Joe® easier because all that has to be known to close the valve is to push the lever down. The driver does not have to remember under the pressure of an emergency situation different closure procedures for different ESVs.



Figure 2. Type P164B Cable Release

Fisher Emergency Shutoff Valves are listed with Underwriters Laboratories as a primary shutoff valve. The valve is designed to be a “working” shutoff, meaning a globe or angle valve does not have to be installed with a Snappy Joe® at the bulkhead unless the user desires to do so. However, no ESV eliminates the need for a means of shutoff at the stationary storage tank. NFPA 58, Section 5.7.7 gives a listing of what valving is required in the stationary storage

Standard construction Snappy Joe® ESVs can be remotely closed by either a cable or a pneumatic cylinder and cannot be opened from a remote location. This was done to assure that inadvertent opening of the valve from a remote point could not take place. A special cylinder actuator, Type P327C, is available that will both open and close the ESV from a remote location, but special precautions must be taken so as to not inadvertently open the valve at the wrong time. The person making the transfer should have control to open the ESV.

Cable Closure

The standard Snappy Joe® comes with a latch mechanism with a looped cable attachment. A remote release cable such as the type P164B, consisting of a release mechanism and 50 feet (15,2 m) of cable, avoids many of the problems associated with ordinary cable. Since Type P164Bs use a shielded cable, ice and dirt are less likely to pose a threat to cable movement. And the cable requires far less guiding; a number of bends can be made without affecting its ability to close the Snappy Joe®. Attachment is made to the valve’s latch mechanism after removing the looped cable portion, a procedure described in the Type N550 instruction manual, Form MCK-1149.

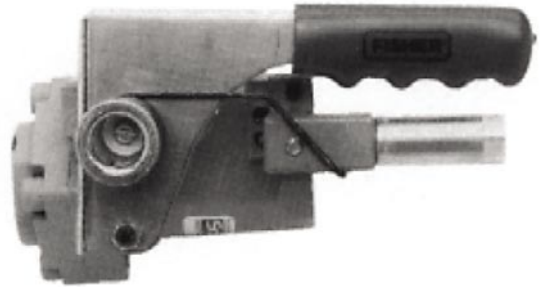

Figure 3. Type P327D Pneumatic Release

For more details on cables and cable installation see the section on Cable Operation on page 8.

Pneumatic Closure

A pneumatic closure system (using a Snappy Joe® a Type P327D cylinder) should be considered when any of these conditions are present:

1. More than one ESV is required at the installation.
2. Remote closure point is a long distance from ESV.
3. More than one remote closure point is desired.
4. Other valves in the system are pneumatically operated.

All bulk plant ESV control systems should be hooked-up so that activating any of the remote closure controls closes all ESVs (and internal valves) in the bulk plant. Each ESV, of course, should also be capable of individual control for normal operations. This is easy to do with the Type N550-P327D because the cylinder actuator can be left pressurized continually and depressurized only when emergency closure is required.

For more details on pneumatic controls see the section on Pneumatic Operation on page 10.

ESVs for Tank Cars

Unlike bobtails and transports, railroad tank cars are not equipped with internal valves. So on tank car installations ESV protection is required on both sides of the hose or swivel piping. The valving for the unloading riser side of the installation can be the same kind of ESVs or back check valves used on conventional hookups. For the tank car side of the hose, however, Fisher felt conventional ESVs were too heavy and

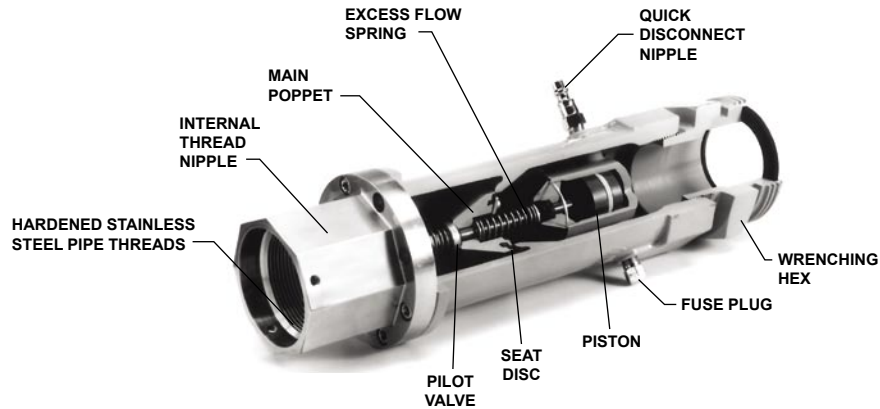

Figure 4. Type N562 Snappy Joe® ESV for Tank Cars

awkward to install, and the Type N562 Snappy Joe® ESV was developed specifically for tank cars.

Exactly the same pneumatic accessories can be used for the Type N562 as the Type N550/P327D covered previously. The same amount of supply pressure (50 psig; 3,4 bar) can also be used, making a pneumatic tie-in between all Snappy Joes® (and internal valves) in the system possible. In this way the entire bulk plant, including the tank car, could be shut down from one or more widely separated locations.

Back Checks and Internal Valves

ESVs are not required in every instance, and two other valves could be used under certain conditions to gain NFPA 58 compliance. Where flow is only into the stationary storage tank, such as transport truck unloading point, a back check valve can be used instead of an ESV. It makes sense to use back check valves wherever possible because they are the only valve in the system that works automatically, i.e., when flow stops, the valve closes without action on anyone's part.

Conventional back check valves were not felt to be of rugged enough construction to function in-line at the bulkhead day after day. For this reason, Fisher introduced the G200 Series of back checks, a valve similar in body construction to the Type N550 Snappy Joe® valves with heavy duty steel and stainless steel internal parts. Type G201 has a built-in flow indicator and could take the place of the sight flow indicators.

Another option is the internal valve where the 20 feet (6,1 m) lineal piping distance can be met. Some bulk plants already use internal valves in the stationary storage. Where this is the case, all that's needed is a

fusible element at both the internal valve and within 5 feet (1,5 m) of the hose and a way to close the valve at the valve, such as a Type P340 manual latch or 3 way pneumatic valve installed at the valve and at a safe remote location.

The Type C427 internal valves have proven themselves on truck applications, and many LP-gas dealers use the valves in stationary storage instead of an excess flow valve-globe valve combination. The Type C427 can be closed by cable or pneumatically.

Bulkheads

All Fisher installation drawings of ESVs, back checks, or internal valves show a bulkhead because of NFPA 58, §6.10.8, wording requires for valving to be "...installed in the plant piping so that any break resulting from a pull will occur on the hose or swivel type piping side of the connection while retaining intact the valves and piping on the plant side of the connection." If the fixed piping can be damaged by a pull, the safety features the valves were meant to provide become worthless.

There are a number of prefabricated steel bulkheads now on the market, and it is also possible to make a bulkhead out of concrete. Many of the prefabricated bulkheads have undergone pull tests to make certain they can withstand the force generated by a truck attempting to leave without being disconnected. These tests clearly demonstrated the strength of LP-gas hose, taking in the neighborhood of 10,000 to 14,000 pounds (4536 to 6350 kg) of pull before either the hose or a pipe fitting broke. At this kind of force the valving in the truck could be pulled out even though the bulkhead remained unharmed.

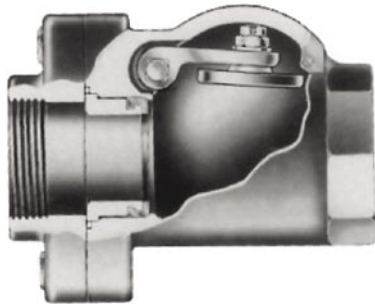

G200 OR G201



G201

Figure 5. Type G201 Back Check Valve

One way of reducing the amount of pull necessary to cause a break is to install the piping at the bulkhead as shown in the installation drawing, Figure 8. A lever arm is created by the pipe, and tests have shown that the pipe breaks at the bulkhead at a much lower pull force. (This force can be controlled by changing the length of the lever arm.) By reducing the number of pounds of pull it takes to cause a break, both the valves in the truck and in-line at the bulkhead are in less danger of being damaged.

Valves For Bulk Plant and Industrial Plant Container Liquid Openings

The 2001 edition of NFPA 58 gave new valve requirements for ASME storage containers over 4000 gallons (15 142 l) for both new and existing containers used in Bulk Plants and Industrial Plants. The 2004 edition of NFA 58 further clarified the requirements found in paragraphs 5.7.7.2 and 5.7.7.3 by adding a Table 5.7.7.3 to help clarify the new and retrofit requirements. The code changes provide for the installation of internal valves which have multiple actuation methods. With this change in the code, if there is a break in the piping between the container and the ESV; or fire in the area of the container liquid valves, there is now a method available to the operator to close the container valve from a remote location and thus keep product in the storage container. The new requirements provide for:

- Thermal closure,
- Remote closure by cable or pneumatics and
- Signage for the remote closure locations.

If you already have internal valves in your tanks, remote shutoff locations and signage must be added to the valves, if not already installed, to comply with the requirements.

Finally, NFPA 58 requires that all existing containers over 4000 gallons (15 142 l) used in bulk plants and industrial plants be upgraded or retrofitted with internal valves, ESVs or back check valves by July 1, 2011, to meet the new requirements.

Internal Valves In New Installations

Liquid Withdrawal Openings require an internal valve, such as the Type C400 Series, fitted with remote closure and thermal capability.

Liquid Inlet Openings require an internal valve, such as the Type C400 Series, fitted for remote closure and thermal capability.

Internal valves come with either 1 1/4, 2 or 3-inch NPT threaded connections with different body configurations. They are also available in 3-inch or 4-inch flanged connections.

Internal valves can function as an excess flow or as a back check valve, but not at the same time. Whether the valve is open or closed determines when excess flow or back check function is in operation. Internal valves **when open** will function as an excess flow valve with the same limitations as an excess flow valve, mainly they may not always close when you need them to close. Internal valves **when closed** can be used as a back check valve in a tank opening. A differential pressure of 5 to 10 psi (0,35 to 0,69 bar) is generally required to open the internal valve, but when flow stops, the internal valve closes. By connecting the remote release to the internal valve, these valves can be closed from a remote location in the event they are open.

Internal Valves are listed with Underwriters Laboratories as a positive shutoff valve.



Figure 6. Type C427 Internal Valve

Back Check Valves In New Installations

If a container has a dedicated **Liquid Inlet Opening** a back check valve such as the soft seated G105, G106 and G107 or the metal to metal G104 or G112 installed in the container and in combination with a positive shut off valve, Type N310 or N410 Series Globe and Angle Valves installed as close as practical to the back check valve may be used in place of an internal valve.

Since a back check valve closes when flow stops or flow reverses, no remote shutdown is required for this valve installation. **However, it is recommended that you periodically test the back check to make sure it is still operational.**

Retrofit of Existing Storage Containers by July 1, 2011

Containers built prior to the 2001 edition of NFPA 58, if they didn't use internal valves in the openings, had liquid openings with either back check or excess flow valves installed in the container wall and positive shutoff valves installed in the piping close to the container wall. See Figure 9.

These older containers need to be retrofitted with internal valves, ESVs or back check valves by July 1, 2011, to meet the new requirements.

The **Retrofit of a Liquid Withdrawal Opening** that has an excess flow valve installed in the tank and a positive shutoff, see Figure 10, on the outlet of the excess flow valve, requires either:



Figure 7. Type P340 Manual Latch

- **Option 1:** Remove the excess flow and install a Type C400 Series internal valve fitted with remote closure and thermal capability, or
- **Option 2:** Install a Type N550 Series ESV downstream and as close as practical to the positive shutoff valve while keeping the excess flow valve in the tank.

Several options are available for the **Retrofit of Liquid Inlet Openings**, see Figure 10:

- **Option 1:** Remove the excess flow and install a Type C400 Series internal valve fitted with remote closure and thermal capability,
- **Option 3:** Install a Type N550 Series ESV downstream and as close as practical to the positive shutoff valve while keeping the excess flow valve in the tank,
- **Option 4: For dedicated inlets**, install a G200 Series back check valve in the line upstream and as close as practical to the positive shutoff valve and the excess flow valve installed in the container or,
- **Option 5: For dedicated inlets**, remove the excess flow valve and install a back check valve such as the soft seated G105, G106 and G107 or the metal to metal G104 or G112 installed in the container and in combination with a positive shut off valve, Type N310 or N410 Series Globe and Angle Valves installed as close as practical to the back check valve.

What about Vapor Openings

While the new requirements are mandatory for liquid lines for both valves and valve retrofit, they are not mandatory for vapor lines. However, the application can be applied to vapor lines to provide an even safer bulk plant system. Previous editions of NFPA 58

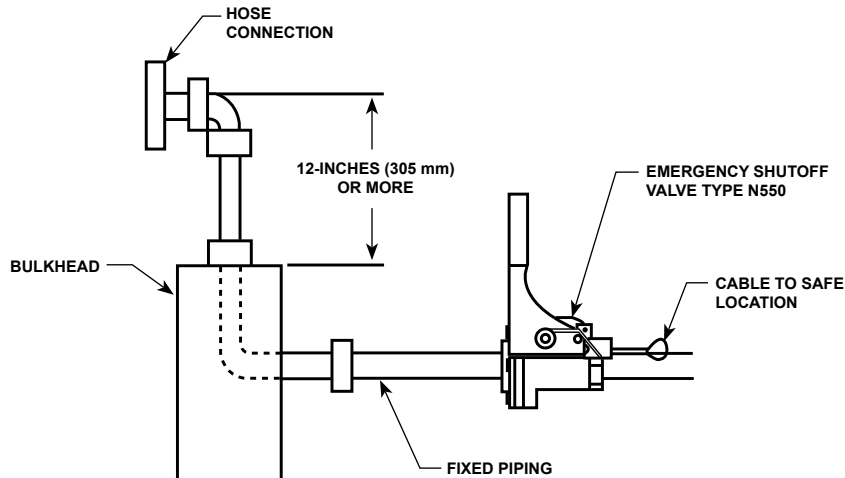

Figure 8. Bulkhead with a Lever Arm

allowed several valve options for Vapor Inlet and Vapor Outlet connections and included the use of internal valves, back check valves, excess flow valves and positive shutoff valves in various combinations. One combination is the use of a positive shutoff as close as practical to a properly sized excess flow valve installed in the tank. If the vapor line is broken with this combination of valves, the excess flow may not close for a number of reasons, or you may not be able to get to the shutoff valve at the tank to close this line. With this scenario you have an uncontrolled flow of vapor that can cause a significant accident because you can't stop the vapor flow.

While the tank is down for retrofit of liquid lines, strongly consider the safety value of replacing the excess flow valve in the vapor lines with either an internal valve, a back check valve where applicable, or installing an ESV in the piping just downstream of the positive shutoff valve. Again these upgrades will give you the ability to shutoff the vapor lines from a remote location which results in a safer bulk tank system.

Some states, Texas for example, do require these same or similar requirements for vapor openings. You should refer to your state requirements regarding valves required for vapor openings.

Internal Valve Actuation Methods

Internal Valves can be actuated by several different methods. They can be:

- Opened and closed manually,
- Opened and closed with a cable system,

- Opened and closed with a pneumatic system, and
- Thermally closed.



CAUTION

An internal valve, when in an open position, does include an excess flow function. Various excess flow spring rates are available. However, because of the limitations, such as piping configurations in size, length, valves and pumps which add restrictions to flow, partial breaks that don't exceed the excess flow rating, and limited inlet pressure at certain times of the year, the excess flow should not be considered a reliable closure method in the event of an emergency.

Manual Operation

Internal Valves, such as the C427 series, have manual latches, Type P340, that allow you to open and close the valve at the installed location. The latch includes a thermal element and can be connected with a remote cable for closure at a remote location. See the section on thermal releases and cable operation.

Cable Operation

A cable system can be used to open and close the internal valve without having to crawl under the tank. A Fisher Type P650 or P651 Primary Cable Control will work with all Fisher threaded internal valves. The

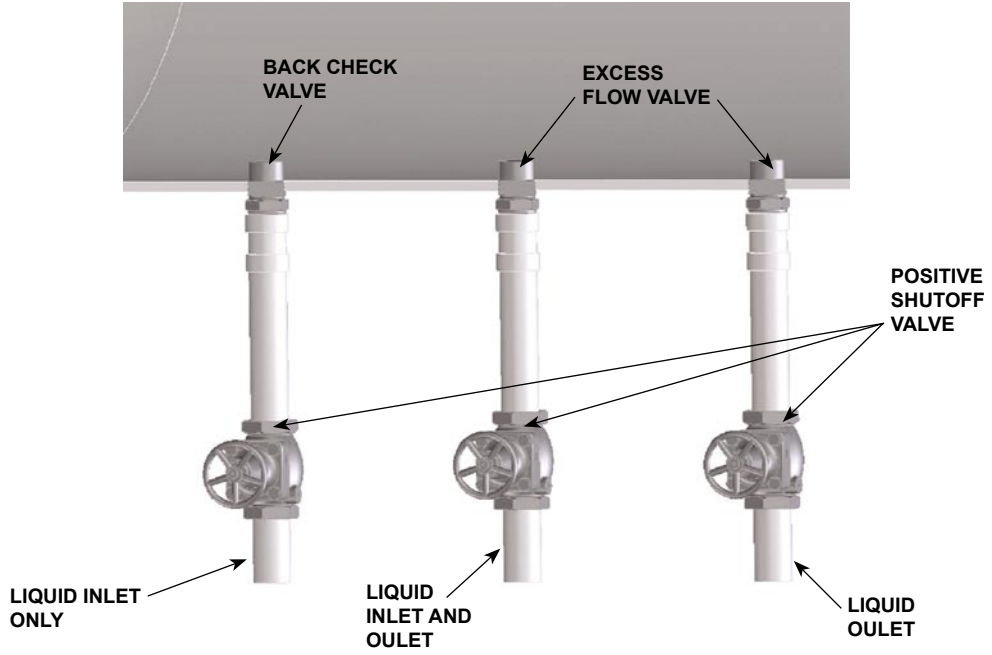

Figure 9. Pre-2001 Liquid Tank Opening Valves if Not Using Internal Valves

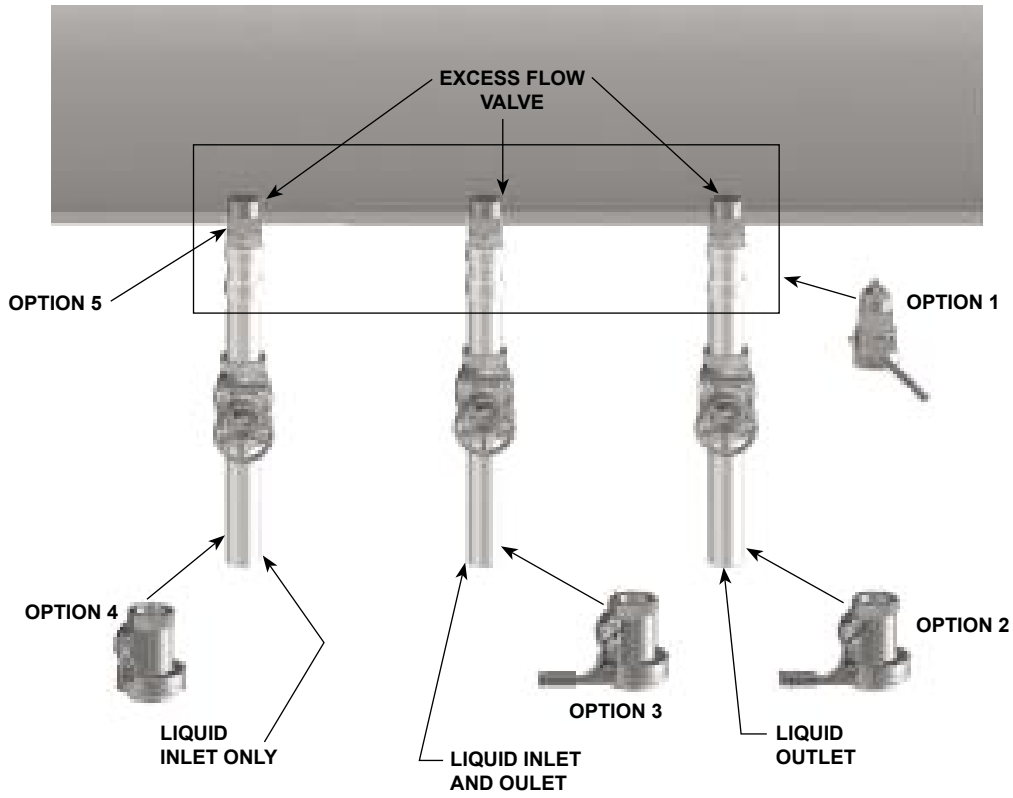

Figure 10. Retrofit Options for Liquid Container Valves

Bulletin LP-29

P650, for example could be installed at the bulk head so that it is easy to open the internal valve. A remote cable is also attached to the P650, so that it can be closed from a remote location. Two fusible links are required; one at the P650 and one at the internal valve where the cable attaches to the lever.

Types P163A and P164A Auxiliary Remote Releases, consisting of a release mechanism and either 25 feet (7,6 m) or 50 feet (15,2 m) of cable, avoid many of the problems associated with ordinary cable. Since they use a shielded cable, ice and dirt are less likely to pose a threat to cable movement. And the cable requires far less guiding; a number of bends can be made without affecting its ability to close the Internal Valves. Attachment is made to the valve's latch mechanism if a manual latch is used or to the P650 if a cable control is used.

A cable system is probably the most economical way to open and close a valve and also provide remote closure capabilities, particularly if there is only one tank at the bulk plant. But cable systems do have limitations. Conduit, pulleys, eyes, or some other means of guiding is needed to run the cable to the internal valve and to run cable to a safe remote location (such as the entrance of the bulk plant). Simply pulling the cable releases the latch mechanism holding the operating lever in the open position.

Open type cables can run into problems in cold weather. Water could get into the conduit and freeze or ice could freeze the cable to the pulleys, making it impossible to close the valve with the cable. Also sharp bends may cause binding and prevent standard cable from being able to close the valve. Cables do stretch, and need to be periodically adjusted. Care must be taken with cable hook-ups to make sure they are capable of not only closing the Internal Valve today but tomorrow as well.



CAUTION

Fisher recommends using the remote cable release at least once a month to make certain that it is still functional. The wrong time to find out that your remote release does not close the Internal Valve is when you need it in an emergency.

Pneumatic Operation

A pneumatic closure system should be considered when any of these conditions are present:

1. More than one bulk storage container is at the Bulk Plant or Industrial Plant
2. More than one internal valve is required at the installation.
3. Remote closure point is a long distance from the Internal Valve or ESV.
4. More than one remote closure point is desired.
5. Other valves, such as ESV at the bulk head, in the system are pneumatically operated.

All bulk plant Internal Valve control systems should be hooked-up so that activating any of the remote closure controls closes all Internal Valves and ESVs in the bulk plant. Each Internal Valve, of course, should also be capable of individual control for normal operations. This is easy to do with a 3 way solenoid or button valve in the pneumatic line to each valve. If the individual valve needs to be closed, bleeding the pneumatic pressure between the internal valve and the button valve will close the internal valve.

Bottled nitrogen, CO₂, and dry compressed air all have decided advantages as pressure sources. All of them are readily available, are chemically compatible with commercial pneumatic controls and seals, and do not contain impurities to gum up or freeze in the control system. Available in supply bottles of 30 cubic feet (0,85 m³), they can last from months to years in a typical system. Because pressure in the bottles run up to 3,000 psig (207 bar), very high pressure regulators such as welding units or Fisher Type 1301F are required to reduce the pressure to the required level (50 psig; 3,4 bar) is ideal for the Snappy Joe®.

It may be possible to use shop air from small air compressors in the warmer climates. However, in cold weather areas there can be problems with moisture freeze-ups in the lines.

While LP-gas vapor can also be considered as a pressure source, it has several limitations. First, local codes may require metallic or special LP-gas piping for the system. Because system pressure is above 20 psig (1,4 bar), control lines could be restricted from entering buildings, and discharge of gas from the pneumatic control valves may have to have venting to a safe area. Finally, some codes may require U.L. listed control valves which might not be available.

Regardless of codes, the tubing, valves, and seals must be resistant to LP-gas and be capable of operating with deposits of any likely impurities (heavy ends, etc.). Fisher gives a listing of control valves, fittings, and tubing that appears suitable for use

on pneumatic ESV systems in their “Transfer Area Valves and Valves for Bulk Storage Liquid Openings” product sheet. All of this equipment is readily available through air supply outlets.

Just as with cable systems, pneumatic controls need to be checked at least once a week from each remote location to validate that closure from the remote location will actually close the internal valves and ESVs.

CAUTION

Fisher recommends using the remote pneumatic release at least once a month to make certain that it is still functional and will close the internal valves and ESVs. The wrong time to find out that your remote release does not close the Internal Valve is when you need it in an emergency.

Thermal Operation

All Fisher internal valves can be closed by thermal activation. All thermal elements supplied by Fisher will release in the 208° to 220°F (98° to 104°C) temperature range. A thermal element must be installed within 5 feet (1,5 m) of the internal valve.

In some cases the thermal element is part of the latch mechanism, such as in the P340, P341, and P342 manual latches. With cable systems, a fusible link must be installed between the cable and the lever at the valve and at the P650 primary cable control.

For pneumatic thermal releases, either 1/8 or 1/4 NPT fusible plugs are supplied or made available. The fusible plugs should be installed at the inlet of the control cylinder at the valve. If plastic tubing is used for the pneumatic system, the fusible plugs must still be used to validate the requirement for thermal release at no more than 250°F (121°C). While plastic tubing will melt, it is seldom marked with its melting temperature and different grades may melt at different temperatures. The use of a marked fusible plug is validation of the melt temperature for you and the local inspector.

Signage and Remote Closure Locations for All Installations

NFPA 58, §6.9 for Internal Valves and 6.10.10 for ESVs define the requirements for Remote Closure locations. The remote shutdown station must be not less than 25 feet (7,6 m) or more than 100 feet

(30 m) from the liquid transfer point (where the transfer hose attaches to the bulk head). More than 1 remote shutdown location can be incorporated into the system, but there must be at least one that meets the distance requirements. Ideally, the remote shutdown station is the same station used for the ESV remote shutdown. Both systems can be tied together so that activating one device will close the entire plant.

The remote shutdown station must be identified with a sign that is visible from the transfer point. The sign must incorporate the words “PROPANE--CONTAINER LIQUID VALVE EMERGENCY SHUTOFF”. The letters must be not less than 2-inch (51 mm) high block letters on contrasting background.

Operational Issues with Internal Valves

There are a few things that need to be considered when using internal valves in new or retrofit applications. The following addresses some of the more common issues.

Isolation Valves If the inlet piping feeds more than one tank, it is recommended that an isolation valve be installed ahead of the internal valve so that each tank can be isolated during the filling process. If a tank is not isolated, it is possible to overfill one tank while trying to fill another on the same line.

Excess Flow Rate Because internal valves do have an excess flow function, be sure that the excess flow spring chosen is greater than the liquid or vapor withdrawal rate. Typically, a closing flow of 1 1/2 times the withdrawal rate will prevent premature closures during product transfer.

Valve Cable and Pneumatic Actuation Make sure the actuation device is working properly. Never wire the internal valve open. If you do, there is no way to remotely close the valve in an emergency. Make sure your cables are correctly tensioned. They will stretch and will have to be adjusted. Make sure pneumatic systems are charged, do not contain water that can freeze, and that the discharge rate is larger than the input rate for the pneumatic pressure source.

Opening Internal Valves Internal valves open when downstream piping pressure is equal to tank pressure. When the valve lever is moved to the half way travel position, an internal fast bleed is opened to equalize the downstream piping. If piping is not drained, this equalization and opening will be very quick. If the valve will not open consider the following:

- If the piping pressure is 0 psi (0 bar), then the length and size of the piping will determine the amount of time required to pressurize the piping before the valve will open.
- Pneumatic actuators move the lever to the full open position immediately, bypassing the fast bleed feature in the internal valve. With the full open position, it will take longer for the internal valve to equalize pressure and open. Try activating the pneumatic controls several times which will move the valve through the fast bleed position a number of times helping decrease the time to equalize.
- Extreme temperature differences between tank contents and piping contents can result in opening problems on rare occasions.

On Retrofit Tanks the additional things need to be considered.

Half vs. Full Coupling Be sure to determine whether the coupling is a half or full coupling into which the internal valve will be installed. The excess flow rate for a full coupling is less than for a half coupling and could cause premature closure.

Stand Pipes Inside the Tank and Attached to the Coupling If an internal valve is installed into a tank coupling that has a stand pipe, the fill or discharge

rate with an internal valve most likely will be greatly reduced if the stand pipe is not larger than the coupling size. In these cases, the use of a back check or N550 in the downstream piping may be the best alternative.

Conclusion

There's no such thing as the typical bulk plant. Since each plant is unique, transfer area valving needs are going to differ from one installation to another. It's impossible to have a single equipment solution that will take care of every bulk plant.

This is where a Fisher distributor can help you. Fisher has a variety of bulk plant equipment besides the industry's largest selection of ESVs, back checks, and internal valves. Contacting a Fisher distributor assures you of finding all the valves and associated equipment needed to make bulk plant modifications. These distributors are completely familiar with NFPA 58 requirements and can recommend the best and most economical way to gain compliance with the transfer area rulings.

Fisher and Fisher Regulators are marks owned by Fisher Controls International, LLC. The Emerson logo is a trademark and service mark of Emerson Electric Co. All other marks are the property of their respective owners.

The contents of this publication are presented for informational purposes only, and while every effort has been made to ensure their accuracy, they are not to be construed as warranties or guarantees, expressed or implied, regarding the products or services described herein or their use or applicability. We reserve the right to modify or improve the designs or specifications of such products at any time without notice.

Fisher does not assume responsibility for the selection, use or maintenance of any product. Responsibility for proper selection, use and maintenance of any Fisher product remains solely with the purchaser.

Emerson Process Management

Fisher Controls International, LLC.
P.O. Box 8004
McKinney, Texas 75070, USA
Telephone: 1 (800) 588-5853
Telephone: 1 (469) 293-4201