

I. Introduction

Standard Features:

- Latched shutdown for increased safety
- Powerful transmitter with 300 feet range
- Waterproof sealed transmitter
- User enabled/disabled query feature
- Remote ignition relay
- Receiver can respond to multiple transmitters (up to 15)

RSD Description

The RSD is designed to comply with D.O.T requirements for off-truck, remote shutdown capabilities for transport trucks. In the event of an unintentional product release, the operator may remotely kill the vehicle engine and close the internal valve, using a handheld, wireless transmitter.

When a button is pressed on the transmitter, the transmitter sends an encoded 32-bit ID number and commands to the receiver. Only receivers that have that transmitter's ID in its programmed list of transmitters will respond. Receivers can be easily programmed to respond to up to 15 different transmitters.

Arming the System

Upon proper installation, the operator will arm the receiver and provide power to the internal valve solenoid simply by setting the parking brake with the truck engine running.

When the RSD receiver is armed, the wireless link to the transmitter is enabled and the query timer is started; but there is no change to the state of the channel relays. The ignition relay remains off and the ignition circuit is completed through the relay contacts allowing the engine to continue running. Power is routed through the channel 1 relay to the internal valve solenoid, allowing the internal valve to be opened.

With the wireless link enabled, ignition circuit complete, and the internal valve solenoid energized - the RSD system is armed and product transfer can begin.

Shutdown Operation

When the red EMERGENCY SHUTDOWN button on the transmitter is pressed, the channel 1 receiver relay is latched ON. This removes power from the internal valve solenoid, closing the valve and energizing the ignition relay. The ignition relay opens the ignition circuit and stops the truck engine. Latching the relay ON prevents unintentional arming of the system using the transmitter.

Query Operation

In addition to the shutdown function, RSD includes a Query feature that ensures compliance to D.O.T. requirements on some installations. Although query is not required on all installations, its use will ensure transmitter/receiver operation at every delivery. Without it, it would be possible to off-load product even if the transmitter is not functioning.

In the event of an unintentional product release, a transmitter with dead batteries would not provide the protection that it was designed for. The Query feature requires that the operator is attentive to the product delivery process. When Query is used, the operator is occasionally prompted for a transmitter button press. If the transmitter signal is received, the wireless link is healthy and RSD is ready to respond when needed. If the receiver does not receive a query reset from the transmitter, the system safely shuts down. This brief test verifies the wireless link between the transmitter and receiver will be available when needed.

When the receiver is armed by setting the parking brake, a timer in the receiver is started. After 4.5 minutes, the query warning relay is activated to sound an alarm to the operator. The operator then has 30 seconds to press the query button on the transmitter before the system is disabled (internal valve closed and engine killed). Pressing the transmitter query button clears the timer back to zero and de-energizes the query warning relay.

II. Installation

Receiver Location Considerations

The RSD-R2 enclosure is not sealed and must be installed inside the truck cab in a location where it will be protected from water.

If possible, install with the antenna connector on top and the wire hole on the bottom.

Choose a location that will allow access to the cover screws, wire terminal screws, and programming button.

Internal Valve Solenoid Installation

Connect one of the solenoid wires to chassis ground.

Make a weather tight splice to the other solenoid wire and rout it to the receiver's 1 – N.C. screw terminal.

For the solenoid, use 18 to 14 gauge wire. The type of internal tank valve will determine how it is connected to the receiver.

Rego Flomatic Valves

The Flomatic valve opens when the pump starts and closes when the pump stops. For this type valve only the ignition relay is required. When the engine is stopped, the pump will also stop, allowing the valve to close.

Air Operated Valves

To operate air actuated valves; a 3-way air solenoid valve must be installed in the airline to the valve actuator. When the receiver is armed (power applied), the 3-way solenoid will be energized allowing air to pass through the solenoid valve to the valve actuator, opening the internal valve. When the EMERGENCY SHUTDOWN button on the transmitter is pressed, power is removed from the 3-way solenoid, blocking the air supply and venting the air in the valve actuator closing the internal valve.

Cable or Manually Operated Valves

Instructions for installing the actuator for manually operated valves are included with the valve actuator.

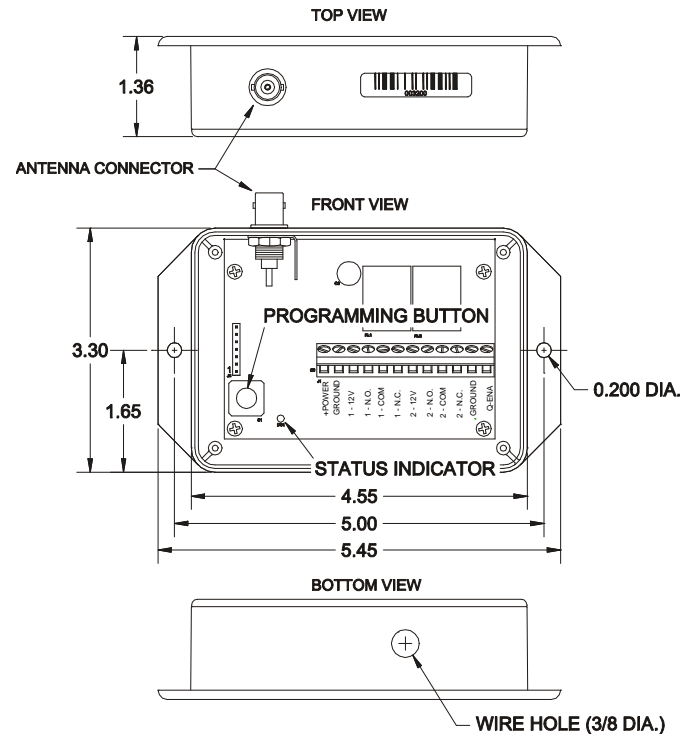

RSD-R2 Receiver

Ignition Relay Installation

The ignition relay must be installed in-line with the ignition HOT wire. When this normally closed circuit is energized:

- the circuit will be broken
- the truck engine will stop
- the internal valve will close

For optimal performance, the relay should be installed as close as possible to the ignition wire, preferably under the truck dash. If installed under the hood, keep the relay and wires clear of engine parts that run hot, such as the exhaust manifold. The dealer service department or truck service manuals will help determine which wire to use for your specific truck make and model.

Wires are attached using crimp-on spade terminals. Use two .187" wide terminals for the coil connections and two .250" wide spade terminals for the relay switch connections. Use 18 to 14 gauge wire for the coil.

To install the relay . . .

- 1) Disconnect the HOT cable from the truck battery.
- 2) Cut the ignition HOT wire.
- 3) Connect one end to the relay COMMON terminal.
- 4) Connect the other end to the relay N.C. terminal.
- 5) Connect one relay COIL terminal to chassis ground.
- 6) Connect the other relay COIL terminal to the receiver's 1 – N.O. screw terminal.
- 7) Reconnect the truck battery cable.

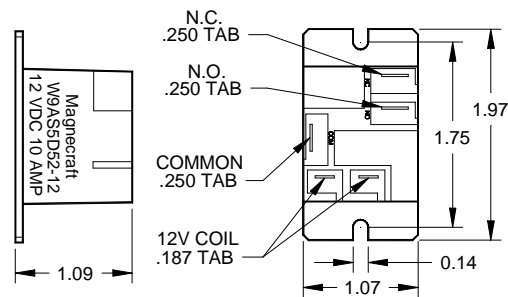

Ignition Relay

Query Installation

If the query feature is used, the query warning relay should be connected to a buzzer, horn, or the reverse beeper to warn the operator that the system is about to shut-off. If your installation does not require a query feature, it can be disabled by shorting the Q-ENA terminal to the GND terminal in the receiver with a short piece of wire.

Query Enable/Disable from Function

On installations where the query feature is enabled, it may be desirable to allow the truck engine to idle with the parking brake set – but not require the operator to query the receiver with the RSD transmitter. The Q-ENA wire terminal in the RSD receiver can be used to enable the query feature only when the truck is actually delivering product.

Shorting the Q-ENA to ground will disable the query feature. If the Q-ENA terminal is “open” or connected to 12 volts, the query feature is enabled.

Choose a function that is only active while transferring product. Some examples of functions that may be used to enable/disable the query feature are listed below.

- **An air pressure switch in the internal valve air hose.** The switch should “open” when air pressure is applied to the valve actuator to open the internal valve. Query is enabled only while the internal valve is “open”.

- **A limit switch that is activated by the valve or PTO pull cable on cable operated trucks.** When the lever is operated or “pulled” at the rear of the truck, the switch should “open”. When the lever is in the valve “closed” or PTO “OFF” position, the switch should be “closed” to disable the query.
- **The PTO or throttle control channels.** If a multi-function receiver, such as the RSD-R6, is used to control PTO and/or throttle, the PTO or throttle channel can be wired directly to the Q-ENA to enable/disable the query on either of those functions.
- **Any electrical event which is active only while transferring product.** For example, an indicator light on the dash for valve “open” or PTO “engaged” could enable the query when the light is ‘ON’. Typically, one side of the light is connected to 12 volts and the other side is grounded to turn on the light. If so, a relay must be installed as shown below.

On some installations it may be possible to locate a source that is at 12 volts only while pumping, and grounded when not pumping. If not, then a relay must be used to enable/disable the query feature. The figure below illustrates connections to a PTO indicator lamp that is ‘ON’ when the PTO is “engaged”.

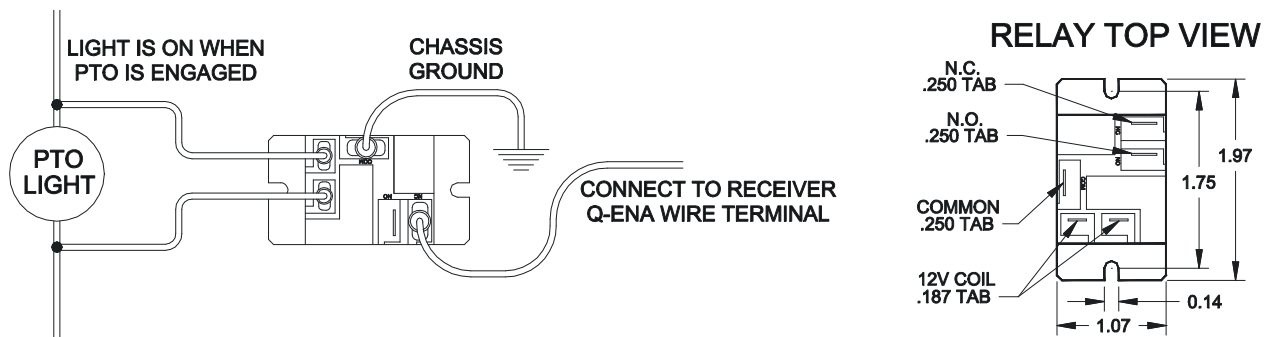

1. Connect the two relay coil wires directly across the PTO lamp, as shown. Polarity is not important.
2. Connect the relay COM to a good chassis ground.
3. Connect the relay N.C. to the RSD Q-ENA wire terminal.

When the lamp is on, the relay will switch, removing the short to chassis ground on the Q-ENA terminal. When the PTO is “engaged” the RSD query feature is enabled. With the PTO light off, the Q-ENA terminal will be shorted to ground through the relay, disabling the query feature.

Antenna Installation

The antenna should be installed at the rear of the tank and as high as possible. If there is risk of damage to the antenna from low tree limbs, the antenna can be installed on the top of the meter cabinet.

Verify that the cable is long enough to reach the receiver and can be safely routed before mounting the antenna. Mounting brackets, magnetic mount bases, high gain antennas, and custom length cables are available.

Contact your local distributor or Squibb-Taylor for details and/or specification.

Receiver Power Source

The +12 volt power source to the receiver must be switched ON and OFF by the ignition key, and remain 'hot' or live while cranking.

Route the +12 volt power wire through a 10 amp fuse and then through a pressure switch as shown in the schematic.

IMPORTANT!

To prevent the receiver from being armed while driving, power should only be applied during pumping operations. This can be accomplished by routing the +12 volt wire through a pressure switch. The pressure switch is connected to the parking brake air circuit. When the parking brake is set, the switch closes, connecting power to the receiver.

RSD-R2 Receiver Schematic

The receiver, internal valve solenoid, and ignition relay should be installed before routing wires.

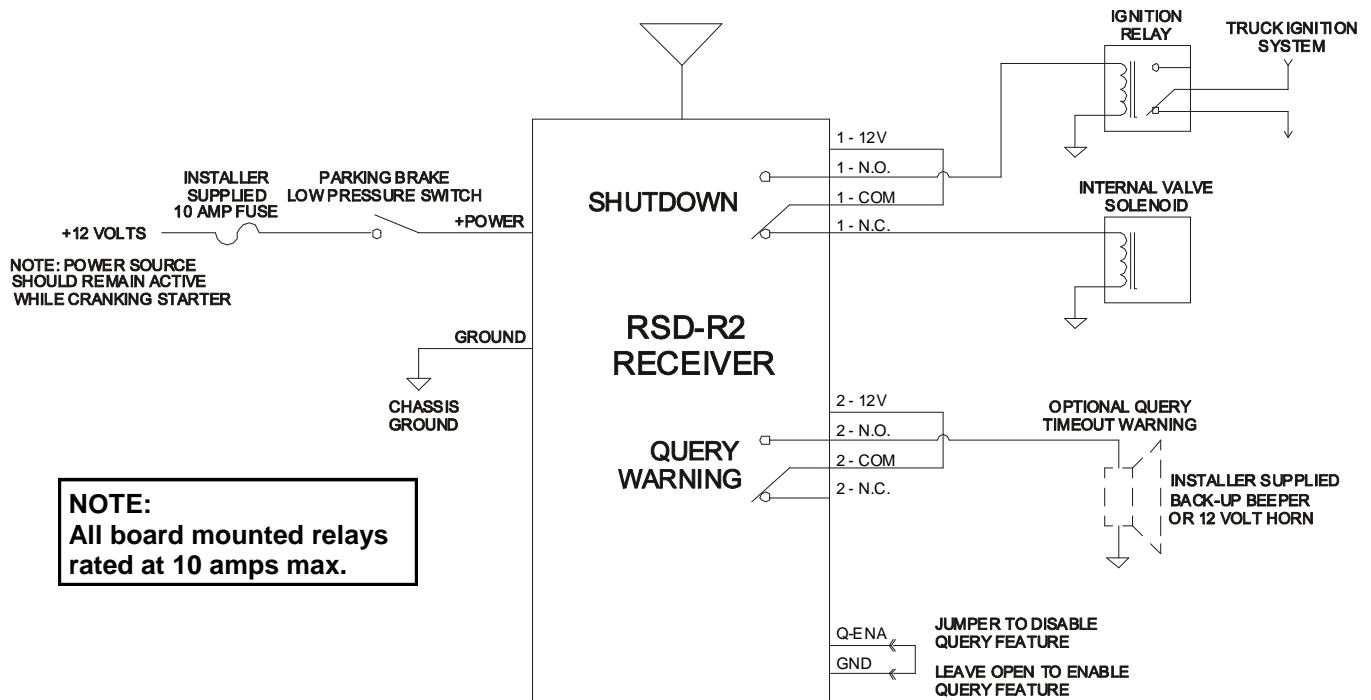

RSD-R2 Wiring Diagram

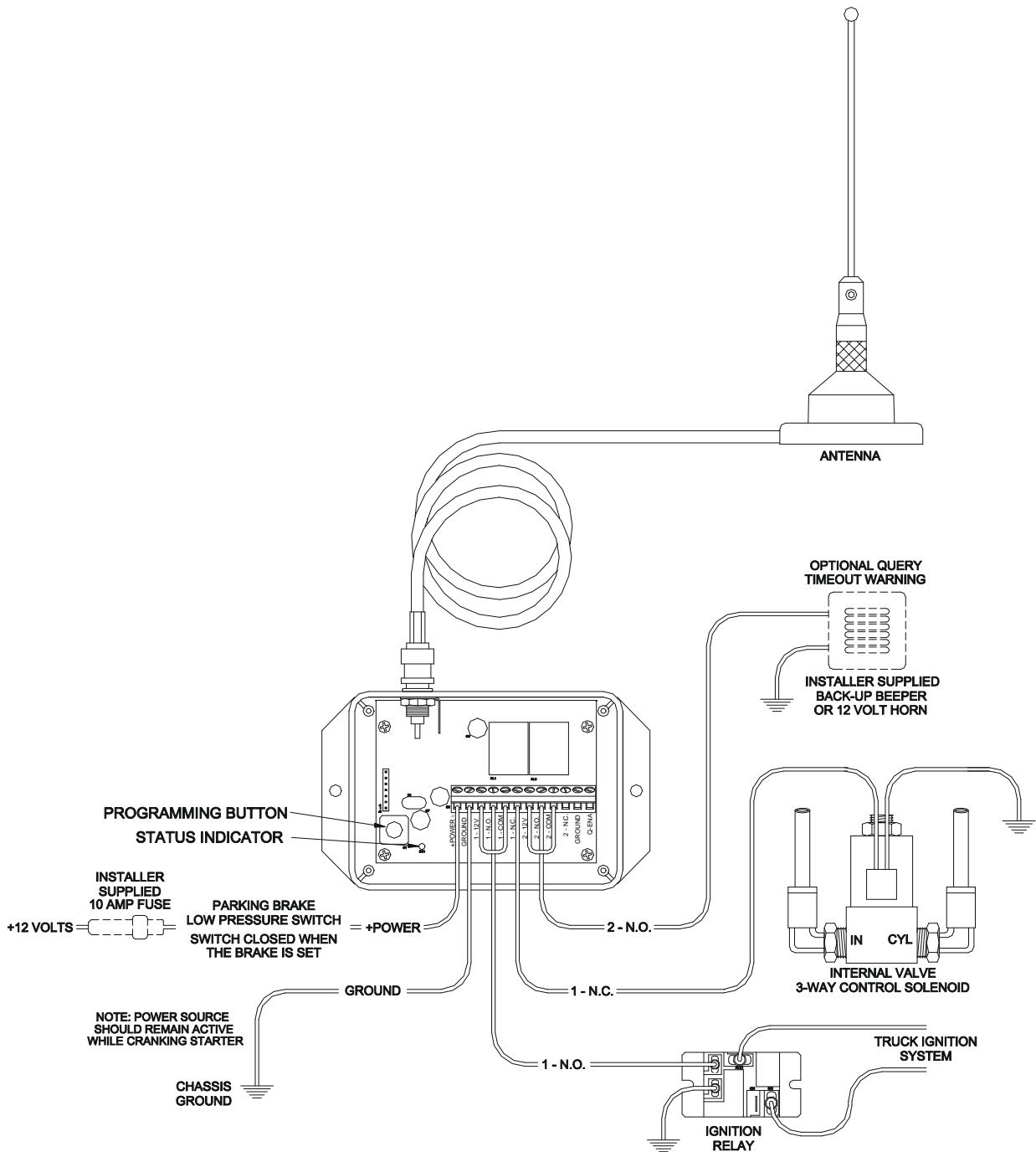

WARNING!

It is extremely important that the power which arms the RSD device be routed in such a manner to make it impossible for the device to be armed while the vehicle is moving. Typically this is done by routing the arming power such that power is supplied only when the parking brake is set. This **MUST** be done to eliminate the possibility that accidental actuation of the safety system would *kill the engine in a moving vehicle situation*.

III. Operation

Programming the Receiver

The receiver keeps a list of transmitters that it will recognize and respond to.

Each time the receiver decodes a valid received packet, it compares the received 32-bit transmitter ID code to those that are in the receiver's list. If the code is in the list, the receiver will process the received packet, activating the required channel.

Receivers are shipped with the transmitter table cleared. At least one transmitter must be added to the receiver's list before it can be used.

To add a transmitter to the receivers list . . .

- 1) Remove the cover on the receiver.
- 2) Apply the parking brake.
- 3) Switch the ignition key on, to supply power to the receiver.
NOTE: The status indicator inside the receiver should be ON.
- 4) With the status indicator ON, press and hold the programming button until the status indicator blinks (about 5 seconds). Release the button when the indicator starts blinking.
- 5) Press and hold one of the transmitter buttons until the status indicator stops blinking.
- 6) The receiver has added the transmitter to its list and is ready to be used.

The receiver's status indicator will flash each time a valid packet is received from a transmitter that is in the receiver's list of programmed transmitters. Press the QUERY button on the transmitter and verify that the status indicator flashes while the button is held down. This will confirm that the receiver has been correctly programmed.

To clear all transmitters from the list . . .

With the status indicator ON, press and hold the programming button. After 5 seconds the indicator will flash. Keep holding the button for an additional 10 seconds until the indicator stops flashing and is on solid. Release the button when the status indicator stops flashing. All transmitters will be cleared from the list. The receiver will need to learn at least one transmitter before it can be used.

If the transmitter list in the receiver is full, (it already has 15 transmitters) the oldest transmitter in the list will be overwritten with the new transmitter ID code.

The list is saved, even when power is removed from the receiver.

Resetting the Receiver after a Shutdown

After a shutdown the receiver must be reset manually:

- 1) With the parking brake set, turn off the ignition key.
- 2) Re-start the truck.

IV. Testing the System

IMPORTANT: Test the System Daily

To comply with D.O.T. requirements, the system must be tested before the first delivery each day at a distance of 150 feet from the cargo vehicle from a location where there is an unobstructed view of the cargo vehicle.

After completing the installation, the system should be thoroughly tested to confirm that all channels perform correctly.

After the initial installation, verify that the shutdown system closes the internal valve and stops the truck engine from a distance of 300 feet.

This test must be done with an unobstructed view of the truck in a clear, open area.

Subsequent shutdown system tests should be performed from a distance of 150 feet before the first delivery each day.

NOTE!

The transmitter will not reset the receiver after shutdown. All RSD functions will be disabled after a remote shutdown. To reset the receiver, the ignition key switch must first be turned off, and then the truck restarted. With the parking brake set and the engine running, the system is re-armed.

V. Warranty

Squibb-Taylor warrants the product identified herein to be free from defects in material and workmanship under normal use and service for **four years** from the date of purchase.

The owner's responsibility is for normal maintenance and any servicer's travel and labor charges.

This warranty applies only when the product is used for consumer use within the United States and Canada and is installed and used in accordance with all applicable national, state, and local codes, regulations, and laws.

This warranty shall not apply if the product has been subjected to unreasonable use, negligence, accident in transit, alteration, improper installation or misapplication.

Squibb-Taylor shall not be liable for any default or delay in performance under this warranty caused by any contingency beyond its control including without limitation to war, government restrictions or restraint, strikes, fire, flood, or a shortage or reduced supply of raw material.

There are no expressed warranties other than set forth above. All implied warranties, including the implied warranties of merchantability and fitness for a particular purpose, are limited to the duration of the expressed warranties set forth above. Liability for consequential damages under this warranty is excluded to the extent exclusion is permitted by law. This warning gives you certain rights and you may have other rights which vary from state to state.

While this information is presented in good faith and believed to be accurate, the manufacturer does not guarantee satisfactory results from reliance upon such information. Nothing contained herein is to be construed as a warranty or guarantee, expressed or implied, regarding the performance, merchantability, fitness or any other matter with respect to the products, nor as a recommendation to use any product or process in conflict with any patent. The manufacturer reserves the right, without notice, to alter or improve the designs or specifications of the products described herein.