

MEP801PIK / MEP801PIKL / MEP801PIH / MEP801PIHL

SMART INTERLOCK TECHNOLOGY

HOSE END VALVE HOLSTER INSTALLATION AND OPERATING INSTRUCTIONS

Application:

Designed to provide a durable and convenient receptacle to store bobtail hose end delivery valves during over-the-road transit. This holster can be mounted fully above deck or partially below deck in left or right hand hose reel applications with an ergonomic angle providing optimum conditions for delivery personnel. Optional (MEC) Smart Interlock Technology is available for direct connection to Allison® automatic transmissions through the "auxiliary function range inhibit" or braking systems for manual transmission vehicles.

(MEC) Smart Interlock Technology prevents the vehicle from being operated while the hose end delivery valve is in use. This revolutionary system incorporates the industry's best and most durable sensor - Turck® - which is backed with a lifetime product warranty.

Features:

- All aluminum & stainless steel construction
- Urethane anti-vibration valve sleeve to prevent incidental damage to delivery valve
- Machined adjustment ribs for easy, secure height adjustment
- Holster body reversible for left or right mount hose reels with universal mounting angle
- Supplied with all mounting hardware & deck backing plate
- Available with optional (MEC) Smart Interlock Technology
 - Interlock Technology features "potted" Turck® proximity switch for maximum weather resistance and security against vibration
 - Supplied with water tight conduit & necessary wiring hardware to reach 5' below deck with water tight receptacle plug
 - Optional wiring harness cable kits available in 20' or 30' lengths
 - Available with optional low temperature sensor for extreme environments

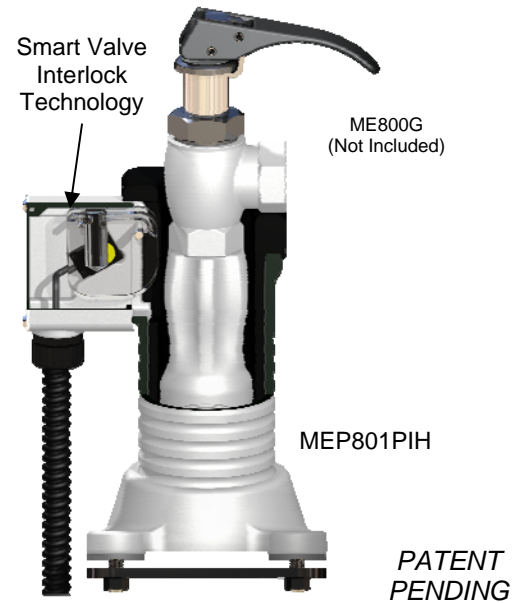

Part #	Description
MEP801	Hose End Valve Holster Assembly
MEP801PIH	Hose End Valve Holster Kit w/ (MEC) Smart Interlock Technology (160° F. to -20° F. Range)
Accessories	
Part #	Description
MEP801PIK	(MEC) Smart Interlock Retro Fit Kit for MEP801 (160° F. to -20° F. Range)
MEP801PIKL	Low Temperature (MEC) Smart Interlock Retro Fit Kit for MEP801 (160° F. to -50° F. Range)
MEP801PC/20	20' Smart Interlock Cable w/ Water Tight Receptacle Plug - Only
MEP801PC/30	30' Smart Interlock Cable w/ Water Tight Receptacle Plug - Only
MEP801PCK/20	Complete 20' Smart Interlock Cable Kit w/ 1 Relay / LED Power Indicator / Inline Fuse
MEP801PCK/30	Complete 30' Smart Interlock Cable Kit w/ 1 Relay / LED Power Indicator / Inline Fuse
MEP802PCK/20	Complete 20' Smart Interlock Cable Kit w/ 2 Relays / LED Power Indicator / Inline Fuse
MEP802PCK/30	Complete 30' Smart Interlock Cable Kit w/ 2 Relays / LED Power Indicator / Inline Fuse
MEP803PCK/20	Complete 20' Smart Interlock Cable Kit w/ 3 Relays / LED Power Indicator / Inline Fuse
MEP803PCK/30	Complete 30' Smart Interlock Cable Kit w/ 3 Relays / LED Power Indicator / Inline Fuse
Replacement Parts	
Part #	Description
MEP801-03	Replacement Urethane Holster Sleeve - Black
MEP801-04	Replacement Urethane Holster Strap - Black
MEP801H	Optional Urethane Weather Boot - Black



MEP801PIK / MEP801PIKL / MEP801PIH / MEP801PIHL

UNIVERSAL VALVE HOLSTER INSTALLATION AND OPERATING INSTRUCTIONS

Scope

The MEP801 Universal Valve Holster is available with the proximity sensor factory installed (MEP801PIH, MEP801PIHL) or can be field-upgraded with a sensor kit (MEP801PIK / MEP801PIKL).

Specifications

Supply Voltage: 10-30 VDC
Max Current Draw: 200 MA (0.2A)
Sensor Type: Normally Open
Relay Type: Normally Open
Fuse Rating: 1 AMP
Temperature Limits: -20° F. to 160°F. (MEP801PIK/ MEP801PIH)
Temperature Limits: -50°F. to 160°F. (MEP801PIKL/ MEP801PIHL)

Installation

WARNING: Failure to follow these instructions or to properly install and maintain this equipment could result in an explosion and/or fire causing property damage or personal injury or death. Marshall Excelsior Company equipment must be installed, operated and maintained in accordance with all federal, state and local codes and Marshall Excelsior instructions. The installation in most states must also comply with NFPA standards 58 and 59, and ANSI K61.1

Only personnel trained in the proper procedures, codes, standards and regulations of the LP-Gas and NH₃ industries should install, maintain, and service this equipment.

Be sure all instructions are read and understood before installation, operation and maintenance. These instructions must be passed along to the end user of the product.

CAUTION: Contact or inhalation of liquid propane, ammonia and their vapors can cause serious injury or death! NH₃ and LP-Gas must be released outdoors in the air currents that will insure dispersion to prevent exposure to people and livestock. LP-Gas must be kept far enough from any open flame or other source of ignition to prevent fire or explosion! LP-Gas is heavier than air and will not disperse or evaporate rapidly if released in still air.

CAUTION: The power supply in your system may produce energy hazards, which can cause bodily harm. To reduce the risk of electrical shock, a trained service technician must disconnect the power supply cables from the battery terminals before installation or service of the system.

NOTE: Before installing, inspect holster and interlock assemblies for shipping damage that may affect performance

MEP801PIK / MEP801PIKL Proximity Interlock Kit. FIELD UPGRADE ONLY

1. Mount Proximity Interlock to Holster (NOT Required for MEP801PIH / MEP801PIHL):

- Remove the (2) bolts holding the sensor plug in place and remove the sensor plug backing plate and sensor plug.



- Insert the sensor paddle into the slot in the receiver as shown, reinstall the (2) bolts and tighten securely.

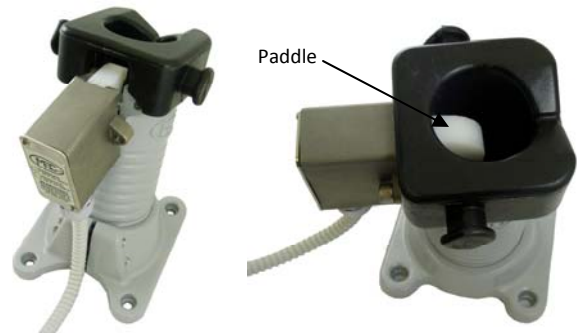

- Check that the paddle moves freely.

MEP801PIK / MEP801PIKL / MEP801PIH / MEP801PIHL Proximity Interlock Holster

2. Route and Secure Conduit

- Determine where the conduit is to be routed and where it will pass through the deck or cabinet wall:
 - To pass sensor plug and conduit through deck or cabinet: drill a 1-1/16" to 1-3/32" diameter hole, route sensor cable thru hole and install grommet as shown.



- Secure conduit to support surface approximately every six to eight inches with suitable conduit clamp or wire tie (not provided)

MEP801PIK / MEP801PIKL / MEP801PIH / MEP801PIHL

UNIVERSAL VALVE HOLSTER INSTALLATION AND OPERATING INSTRUCTIONS

3. Connect Interlock to Allison Transmission “Auxiliary Function Range Inhibit”

WARNING:

- The positive (+) supply conductor of the interlock circuit MUST be protected by a fuse with a maximum rating of 1 AMP, as provided in the MEC Proximity Cable Kits. **It must be replaced only with a fuse of the same rating.**
- The maximum current draw thru the MEP801PIK/L sensor is 200 MA (0.2A)
- Ground connections must be made as indicated by vehicle manufacturers instructions

- Connect the sensor cable plug to the mating connector on the 20' or 30' Single relay (MEP801PCK/20 or MEP801PCK/30), Dual relay (MEP802PCK/20 or MEP802PCK/30) or Universal (MEP801PC/20 or MEP801PC/30) Proximity Cable kit.
- Secure the connection in a protected location and route and secure all cables and wires using loom and wire ties or other suitable means

- Mount the sealed relay using the bracket provided, in either the engine compartment or cab, as desired. **NOTE:** when mounting in the engine compartment, keep relay away from sources of heat and orient wires so they point down.
- Make the electrical connections as indicated on the wiring circuit diagrams included in this manual. For final connections to the Allison “Auxiliary Function Range Inhibit” circuit, follow the manufacturers instructions provided with the Allison transmission. **NOTE:** Only trained personnel that are qualified to make connections to the Allison Transmission's range inhibit function, such as Allison Transmission certified technicians, should make these connections.
- Test the Proximity Interlock / Range Inhibit function for proper operation by installing a hose end valve into the holster or manually depressing sensor paddle and confirming that the red LED in the relay lights up indicating the circuit has been closed, and that the Range Inhibit interlock function allows Allison Transmission to shift out of Park.

Operation

When the hose end valve is placed into the holster the sensor paddle is actuated closing the sensor circuit. The sensor circuit interfaces with the auxiliary function range inhibit allowing the vehicle transmission to be shifted out of the park position.

WARNING: Never stow a leaking valve in the valve holster. Failure to follow these instructions could result in an explosion and/or fire causing property damage or personal injury or death.

Trouble Shooting		
Problem	Possible Cause	Recommended Action
LED on relay does not light or relay does not activate	Relay not properly grounded	Mount the relay bracket to a grounded metallic surface or attach a ground strap between the relay bracket and an electrically grounded connection.
	Protective over-current fuse is blown	Replace the fuse ONLY with a fuse of an identical 1 AMP rating
	No power to sensor	Remove cover on sensor housing to verify green light on Turck sensor, if no light then: <ul style="list-style-type: none"> • Check fuse • Check for 12 volt with key on • Check ground wire from sensor
	No signal from sensor	Remove cover on sensor housing with sensor paddle pushed in verify change light on Turck sensor. If no light then: <ul style="list-style-type: none"> • Sensor needs to be replaced • Paddle needs replaced



MEP801PIK / MEP801PIKL / MEP801PIH / MEP801PIHL

UNIVERSAL VALVE HOLSTER INSTALLATION AND OPERATING INSTRUCTIONS

Trouble Shooting Continued...		
Problem	Possible Cause	Recommended Action
LED on relay does not light or relay does not activate	Wiring—Incorrect or damaged	<ul style="list-style-type: none"> Check for 12 volts at pin 1 of sensor plug with key on Check for 12 volts at pin 2 with paddle depressed and key on Check for continuity between pin 3 and (-) negative terminal of battery Check for continuity between relay black wire and (-) negative terminal of battery Check for any loose crimps or damaged wires Check for corrosion at all wiring connection points
	Faulty relay	Replace relay
LED on, relay is on but truck will not shift out of park	Faulty relay	Replace relay
	Wiring incorrect or damaged	<ul style="list-style-type: none"> Verify connections to and from the TCM of the transmission Check for any loose crimps or damaged wires. Check for corrosion at all wiring connections
Connections test OK but interlock still does not function properly	Damaged or defective proximity sensor, sensor cable or sensor connector pins	Disconnect sensor connector and connect test jumper in its place. If interlock functions properly with test jumper but not with sensor, sensor must be repaired or replaced.

Maintenance

To ensure proper operation, perform the following maintenance:

1. Check that the holster paddle moves freely before each use. Repair or replace interlock if it is not functioning properly.
2. Check that all fasteners are tight at least monthly. Tighten any that are found to be loose.
3. Check sensor relay for proper operation as indicated by red LED light on relay.
4. Check valve retention strap for proper operation and excessive wear. Replace if necessary.

MEP801PIK WIRING DIAGRAM

PROXIMITY INTERLOCK KIT

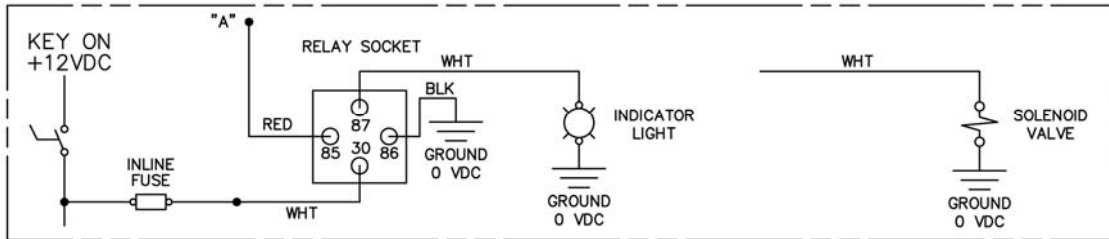
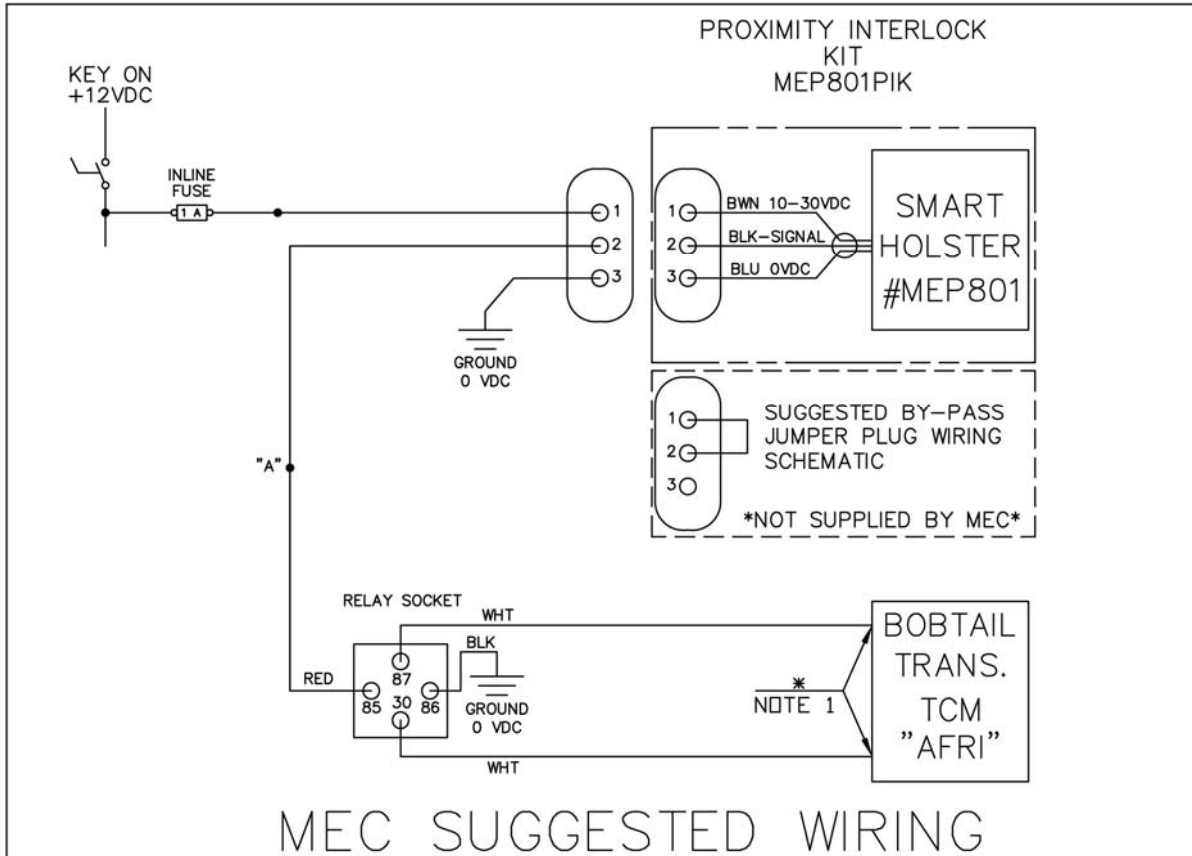

NOTES:

1. CONNECT TO TRANSMISSION PER THE "AUXILIARY FUNCTION RANGE INHIBIT CIRCUIT" OF THE TRANSMISSION TCM.

WARNING - MAX CURRENT DRAW THRU THE MEP801PIK SENSOR IS 200ma.

MARSHALL EXCELSIOR CO.

DRAWN az	NAME MEP801PIK WIRING DIAGRAM	PAGE	DRAWING NO.
DATE 1/22/09	PROXIMITY INTERLOCK KIT	1-1	MEP801PIK-WD



MEP801PCK WIRING DIAGRAM

SINGLE RELAY PROXIMITY CABLE KIT

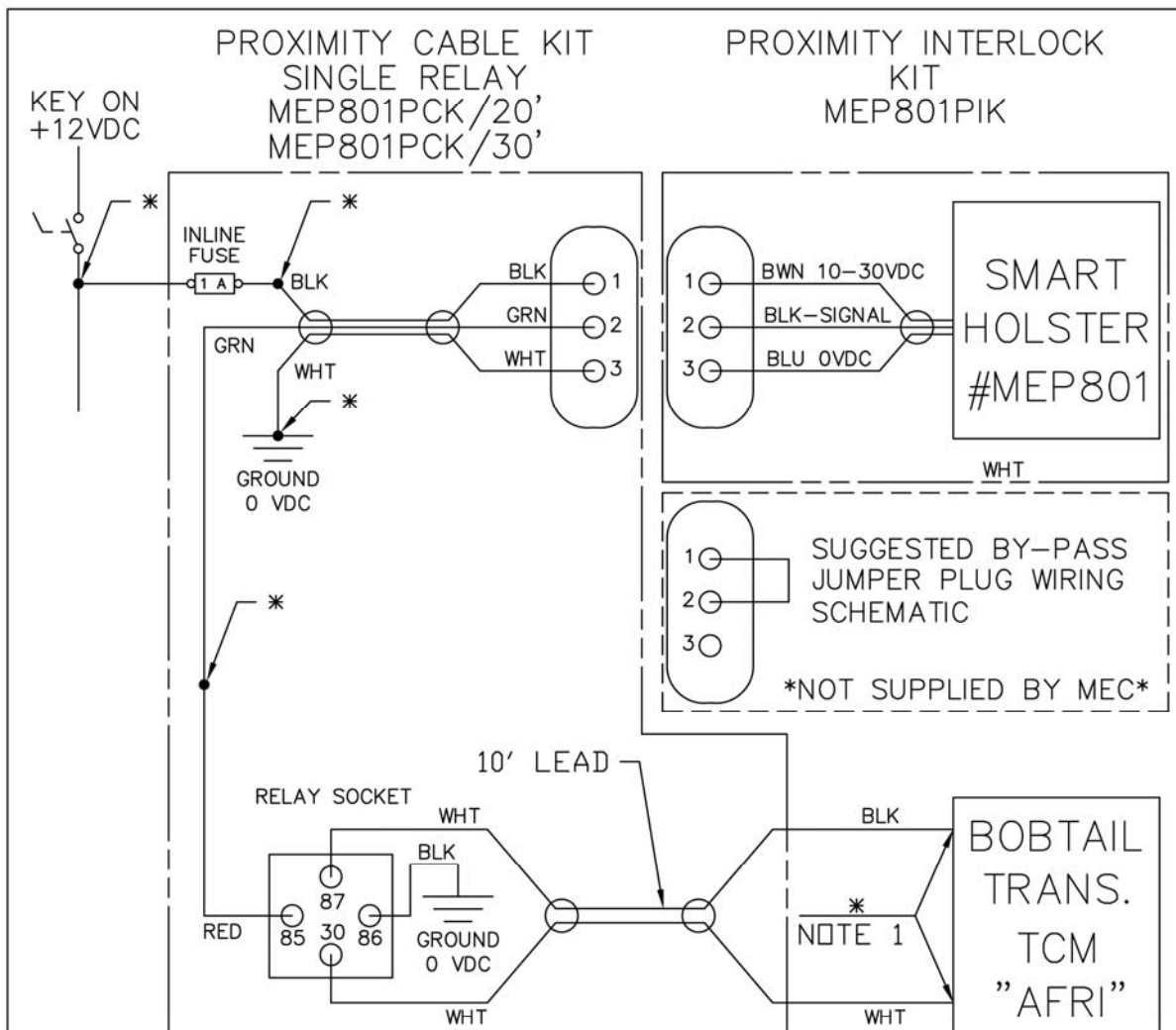

NOTES:

1. CONNECT TO TRANSMISSION PER THE "AUXILIARY FUNCTION RANGE INHIBIT CIRCUIT" OF THE TRANSMISSION TCM.

* CUSTOMER CONNECTIONS.

MARSHALL EXCELSIOR CO.

DRAWN az	NAME MEP801PCK WIRING DIAGRAM	PAGE 1-1	DRAWING NO. MEP801PCK-WD
DATE 1/22/09	SINGLE RELAY PROXIMITY CABLE KIT		



MEP802PCK WIRING DIAGRAM

DUAL RELAY PROXIMITY CABLE KIT

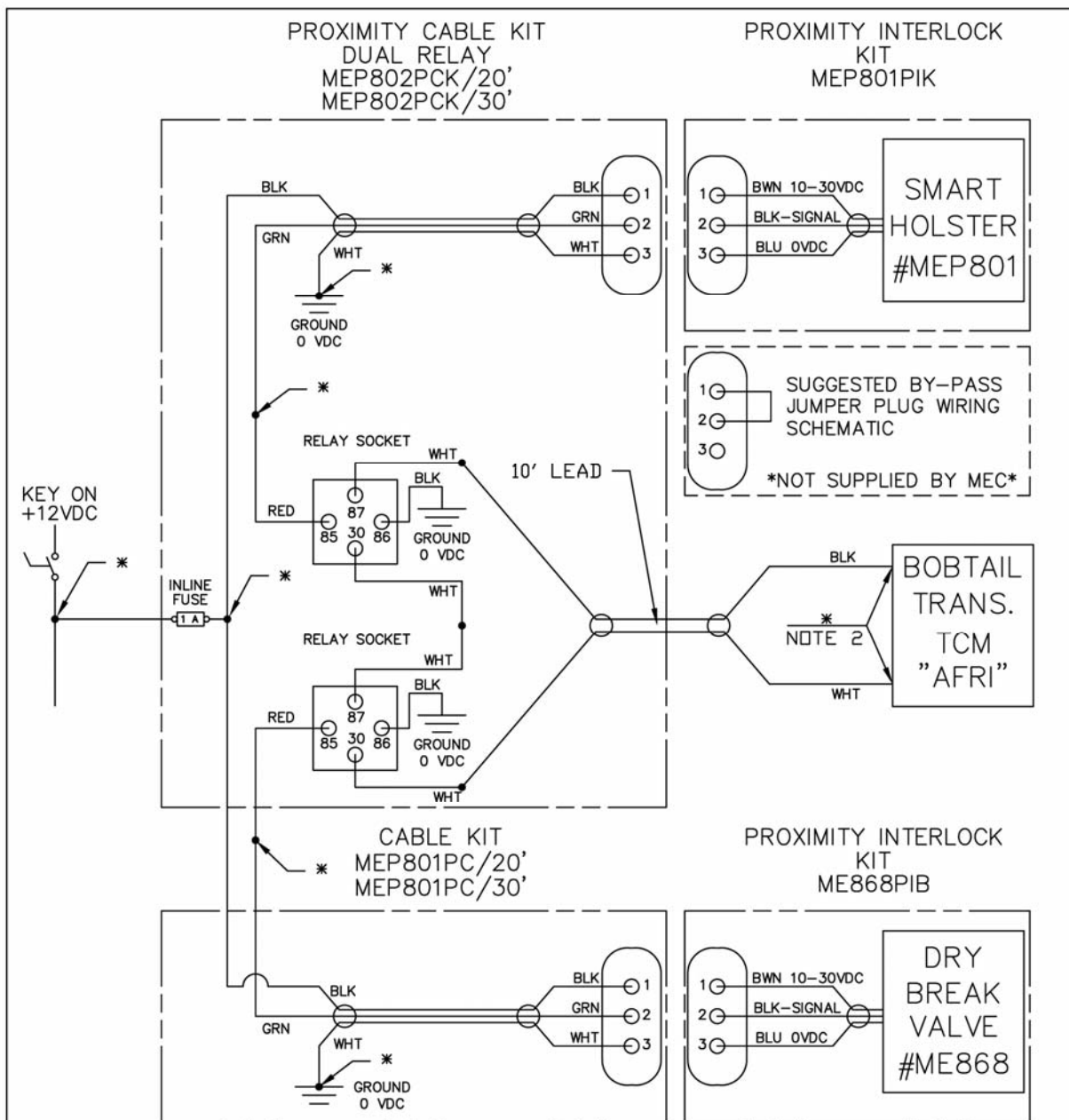

WARNING – MAX CURRENT DRAW THRU THE MEP801PIK SENSOR IS 200ma.

- NOTES:
1. CONNECT TO TRANSMISSION PER THE "AUXILIARY FUNCTION RANGE INHIBIT CIRCUIT" OF THE TRANSMISSION TCM.
- * CUSTOMER CONNECTIONS.

MARSHALL EXCELSIOR CO.

DRAWN az	NAME MEP802PCK WIRING DIAGRAM	PAGE	DRAWING NO.
DATE 1/22/09	DUAL RELAY PROXIMITY CABLE KIT	1-1	MEP802PCK-WD



MEP801PC WIRING DIAGRAM

PROXIMITY CABLE KIT

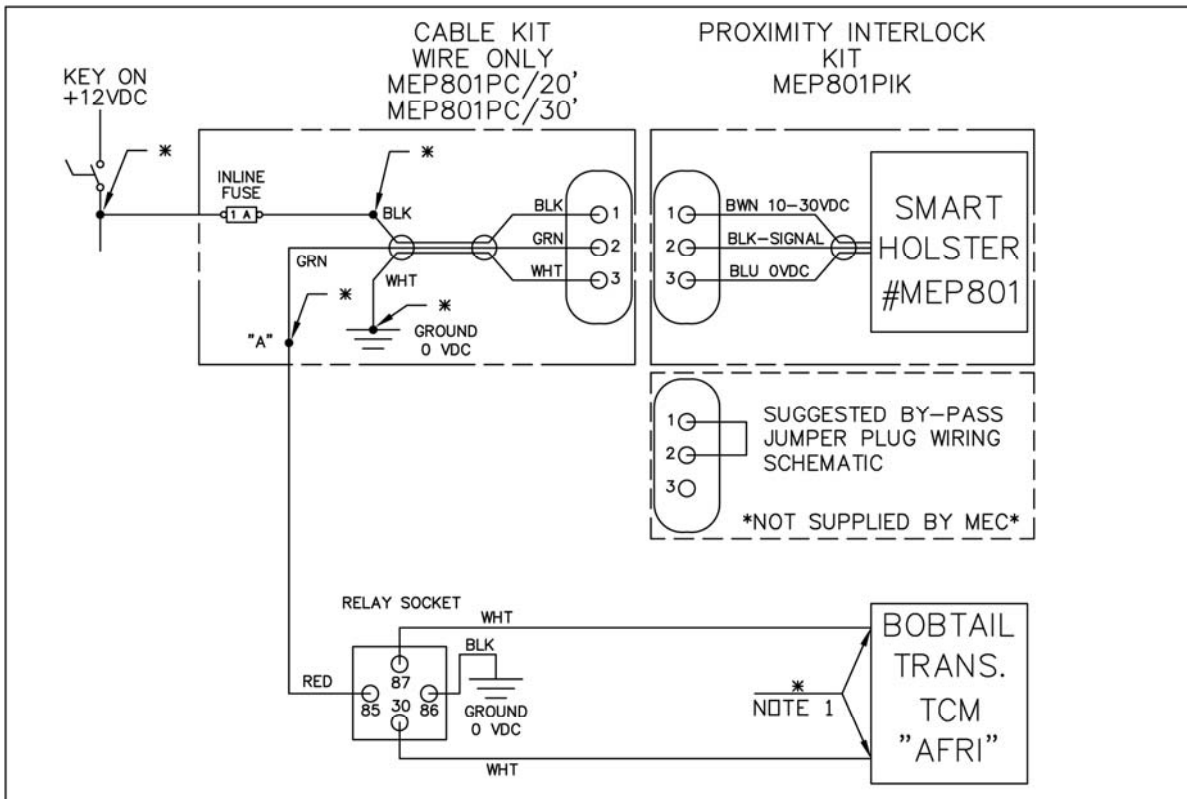

MEC SUGGESTED WIRING

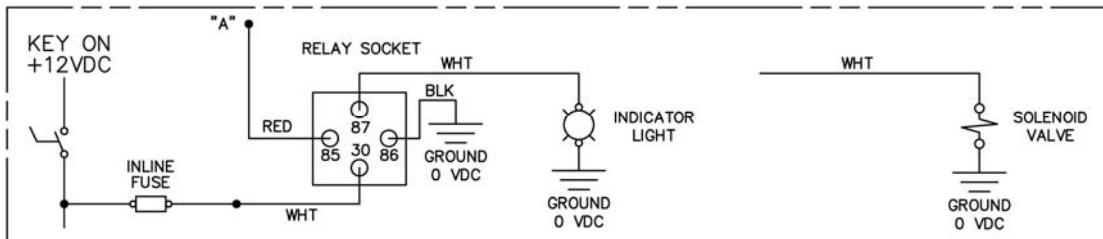

OPTIONAL WIRING

NOTES:

1. CONNECT TO TRANSMISSION PER THE "AUXILIARY FUNCTION RANGE INHIBIT CIRCUIT" OF THE TRANSMISSION TCM.

WARNING – MAX CURRENT DRAW THRU THE MEP801PIK SENSOR IS 200ma.

* CUSTOMER CONNECTIONS.

MARSHALL EXCELSIOR CO.

DRAWN AZ	NAME MEP801PC WIRING DIAGRAM	PAGE	DRAWING NO.
DATE 1/22/09	PROXIMITY CABLE KIT	1-1	MEP801PC-WD

Marshall Excelsior Distributor

Call 269-789-6700,

Fax 269-781-8340

E-mail: sales@marshallexcelsior.com

www.marshallexcelsior.com