

Marshall Excelsior



Gas Connections

MEGR-11301F HIGH PRESSURE REGULATOR

Instruction Manual- Look Inside For:

- Description
- Installation
- Operation
- Maintenance
- Parts Ordering
- Parts List



Marshall Excelsior Company

Marshall, MI 49068

269-789-6700

FAX 269-781-8340

www.marshallexcelsior.com

The contents of this publication are for informational purposes only. While every effort has been made to ensure accuracy, these contents are not to be construed as warranties or guarantees, expressed or implied, regarding the products or services described herein or for their use or applicability. Marshall Excelsior Co. reserves the right to modify or improve the designs or specifications of such products at any time without notice. The MEC™ logo is the trademark of Marshall Excelsior Co.

Description:

The MEGR-11301F is a direct acting, self-operated, brass, high-pressure gas regulator designed for inlet pressures up to 5500 psig (379 bar). The MEGR-11301F provides output pressures up to 500 psig (35 bar) in four separate ranges. This is ideal for reducing large inlet pressures to the much lower supply pressures required for precision regulators. The rugged design of the multi-purpose MEGR-11301F makes it especially useful in Propane and Natural Gas applications.

Warning:

These gas regulators are non-relieving regulators and thus cannot exhaust excess pressure at the regulator. Use of a shut-off valve upstream and relief device downstream of these regulators is recommended in accordance with NFPA 58. In order to establish an accurate output pressure from the regulator, it will be necessary to cycle downstream flow or to set the regulator at a slight flow. Spring case vent holes must remain free and clear.

Specifications:

BODY SIZES AND END CONNECTION STYLES	1/4" NPT (one inlet and two outlets)
MAXIMUM ALLOWABLE INLET PRESSURE	5500 psig (379 bar)
OUTLET PRESSURE RANGES (Brass Only)	0-30psig (0-2 bar) 0-60 psig (0-4 bar) 0-120 psig (8 bar) 0-150 psig (10 bar) 0-225 psig (10 bar) 0-500 psig (35 bar)
PRESSURE REGISTRATION	internal
TEMPERATURE RATING	-40 to 225° F (-40 to 107° C)
SUPPLY ORIFICE DIAMETER	5/64" (2mm)
SPRING CASE VENTS	4X 5/32" ø holes (4mm)
WEIGHT	3.5 lbs (1.6 kg)

Installation:

Qualified personnel only should perform installation, operation and maintenance in accordance with NFPA 54 & 58 and other local, State and Federal Regulations.

Make sure all tubing and piping is clean and unobstructed. The MEGR-11301F may be installed in any position. Apply pipe compound to the pipeline threads. Connect the inlet piping to the 1/4" NPT connection marked "IN", and the outlet piping to (1) of the 1/4" NPT connections marked "OUT". Install a pressure gauge or pipe plug in the unused outlet connection.

Operation:

Once installation is complete, slowly allow upstream pressure to enter the regulator. If adjustment of the regulated pressure is necessary, remove the tamperproof cap (if one is used) with a 3/4" wrench or loosen the 11/16" locknut on the T-handle screw assembly. On tamperproof models adjustment is made with a 7/32" Allen socket wrench. Turning adjustment screw clockwise will increase the set pressure, while counterclockwise will decrease the set pressure. When adjustment is complete, tighten the locknut or replace the tamperproof cover.

Maintenance

WARNING:

To avoid personal injury or equipment damage, do not attempt any maintenance without first isolating the regulator from system pressure and relieving all internal pressure from the regulator.

Regulators should be inspected in accordance with the requirements of local, state, and federal rules and regulations (NFPA 54 & 58). Regulator parts showing wear should be replaced as necessary. The procedure below describes how to disassemble the MEGR-11301F for parts inspection. Assembly is the reverse of this procedure.

1. Remove the tamperproof cover (item 3), if one is used, and turn the adjusting screw (item 2) counterclockwise to remove spring tension.
2. Remove the bottom plug (item 10), gasket (item 14), and spring (item 4).
3. Unscrew (item 17) and remove the seat housing (item 8) and the seat block assembly (item 13) from the diaphragm arm (item 9).
4. Remove the build screws (item 6), and separate the bonnet (item 11) from the body (item 7).
5. Remove the spring guide and spring (items 15 and 1).
6. Remove the diaphragm/diaphragm arm assembly (includes items 5,9,18,20,21) and gasket (item 19).
7. Inspect the supply nozzle (item 16) and the seat block assembly (item 13) for any wear or damage. The seat block assembly can be rotated to provide a new supply seat.

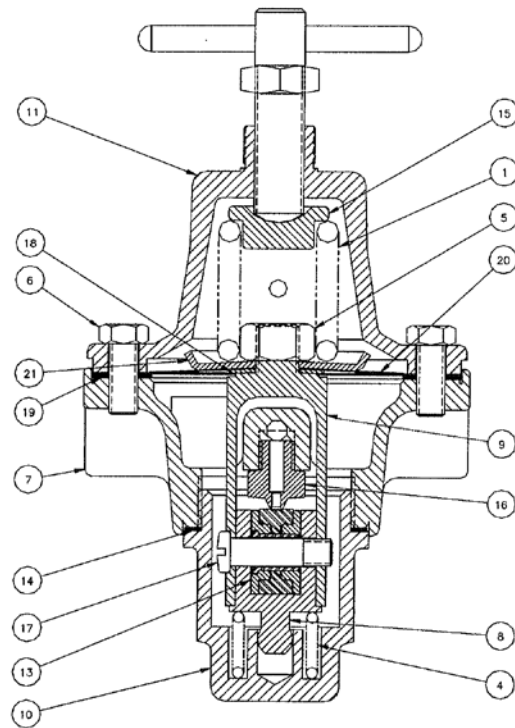

3
2
These 2 items are for the tamperproof version

