



**ME990-4F-SRK
SEAL REPAIR KIT
FOR: ME990-4F 4" SINGLE FLANGE
INTERNAL VALVE**

!!!WARNING!!!

READ AND UNDERSTAND ALL INSTRUCTIONS INCLUDED WITH THIS REPAIR KIT
RELIEVE ALL PRESSURE FROM SYSTEM BEFORE REMOVING VALVE FOR SERVICE

NOTE: Numbers in brackets [] refer to the number in the valve component list.

A. Disassembly

1. **EVACUATE ALL PRESSURE FROM SYSTEM BEFORE ANY DISASSEMBLY OR REPAIR.**
2. Remove (10) Bushings [2] from Valve Body [1] and discard
3. Remove (4) Screws [3] and (4) Washers [4] (if applicable) from Screen [5] and retain.
4. Remove Screen [5] and retain.
5. Remove (8) Cap Screws [6] from Valve Cage [7] and retain.
6. Remove Valve Cage [7] and Closing Spring [9] and retain.
7. Remove Cage Bushing [8] from Valve Cage [7] and discard.
8. Remove Valve Holder Assembly [14] from Valve Body [1].
9. Remove Spring Pin [10] and Retainer [11] from Valve Holder Assembly [14] and retain.
10. Remove Excess Flow Spring [12] from Valve Holder Assembly [14] and either:
 - a. Discard if you have purchased a new Excess Flow Spring [12]; or
 - b. Retain if you did not purchase a new Excess Flow Spring [12].
11. Remove Stem [13] from Valve Holder Assembly [14] and retain.
12. Remove (4) Bolts [14E] and Seal Retainer [14D] from Valve Holder [14A] and retain.
13. Remove (4) Spacers [14C] and Valve Seal [14B] from Valve Holder [14A] and discard. Retain Valve Holder [14A]. Discard (4) Spacers [14C] and Valve Seal [14B].
14. Remove Seat Ring [15] and O-Ring [16] from Valve Body [1].
15. Remove Guide Bushing [17] from Seat Ring [15] and discard Guide Bushing [17] and O-Ring [16].
16. Remove Cotter Pin [18] from Cam Pin [19] and retain.
17. Remove Cam Pin [19] and Cam Assembly [20] and retain.
18. Remove Stub Washer [21] and discard.
19. Remove Cotter Pin [18] and Roller Pin [20B] from Cam [20A] and retain.
20. Remove Roller [20C] from Cam [20A] and retain.
21. Remove Roller Bushing [20D] from Roller [20C] and discard.
22. Remove Rod Wiper [22], Bonnet [23], Female Adapter [24], (3) V-Packs [25], Male Adapter [26], Packing Washer [27], Packing Spring [29], Ejection Spring [28], Stub [30], Stem Bushing [31], and (2) Gland Bushings [32] from Valve Body [1].
23. Discard Rod Wiper [22], Female Adapter [24], (3) V-Packs [25], Male Adapter [26], and (2) Gland Bushings [32].
24. Inspect Valve Body [1] and clean if necessary, be sure interior is free of dirt, residue and foreign particles.

Marshall Excelsior Company

1506 George Brown Drive Marshall, MI 49068
Phone (269) 789-6700 Fax (269) 781-8340
www.marshallexcelsior.com

The contents of this publication are for informational purposes only. While every effort has been made to ensure accuracy, these contents are not to be construed as warranties or guarantees, expressed or implied, regarding the products or services described herein or for their use or applicability. Marshall Excelsior Co. reserves the right to modify or improve the designs or specifications of such products at any time without notice. The MEC™ logo is the trademark of Marshall Excelsior Co.

B. Reassembly

1. Install Roller Bushing [20D] into Roller [20C].
2. Install Roller [20C] into Cam [20A], Install Roller Pin [20B] through Cam [20A] and Roller [20C], Install Cotter Pin [18] and bend around Roller Pin [20B].
3. Install (1) Gland Bushing [32] into Stem Bushing [31].
4. Install shorter side of Stub [30] into Stem Bushing [31].
5. Install Packing Spring [29] and Ejection Spring [28] onto Stub [30].
6. Install Rod Wiper [22] and Gland Bushing [32] into Bonnet [23].
7. Apply lubriplate to Stub Shaft [30] and packing bore on Valve Body [1].
8. Apply lubriplate to Packing Washer [27], Male Adapter [26], inside "V" of (3) V-Packs [25], and Female Adapter [24] and install over Stub [30] oriented as shown.
9. Install Stub [30] into Valve Body [1].
10. Apply Loctite #242 to threads of Bonnet [23] install Bonnet [23] into Valve Body [1].
11. Install Stub Washer [21] onto Stub [30].
12. Install Cam Assembly [20] on end of Stub [30] in Valve Body [1].
13. Install Cam Pin [19] and Cotter Pin [18] and bend Cotter Pin [18] around Cam Pin [19].
14. Apply Loctite #242 to (4) bolt holes in Valve Holder [14A] and wipe excess off seal surface.
15. Install Valve Seal [14B] into Valve Holder [14A].
16. Install (4) Spacers [14C] into Valve Seal [14B].
17. Install Seal Retainer [14D] onto Valve Seal [14B].
18. Install (4) Bolts [14E] into Valve Holder [14A], tighten in a "star" pattern and confirm that all Bolts [14E] are tightened securely.
19. Install Stem [13] and Excess Flow Spring [12] into Valve Holder Assembly [14].
20. Apply anti-seize to threads of Retainer [11] and install into Valve Holder Assembly [14] and tighten securely.
21. Drill $\phi 3/32$ hole through one wall of Retainer [11] using hole in Valve Holder Assembly [14] as a guide. Install Spring Pin [10] into hole in Valve Holder Assembly [14] until flush.
22. Install guide Bushing [17] into Seat Ring [15]. Apply lubriplate to O-Ring [16] and install on Seat Ring [15].
23. Align holes in Seat Ring [15] with holes in Valve Body [1] and install Seat Ring [15] into Valve Body [1].
24. Install Valve Holder Assembly [14] into Valve Body [1] with Stem [13] through Seat Ring [15].
25. Install Closing Spring [9] into Stem [13].
26. Install Cage Bushing [8] into Valve Cage [7].
27. Install Valve Cage [7] over Stem [13]. Align holes in Valve Cage [7] with holes in Valve Body [1].
28. Apply Loctite #242 to threads in Valve Body [1] and install (8) Cap Screws [6] and tighten securely.
29. Install Screen [5] onto Valve Body [1].
30. Apply Loctite #242 to threads of (4) Screws [3] and install (4) Washers [4] (if applicable) and (4) Screws [3] through Screen [5] into Valve cage [7].
31. Install (10) Bushings [2] into Valve Body [1].
32. Connect the valve assembly outlet to a pressure source of at least 150 PSI. Check for leaks at all joints and stem seals using a suitable leak detector solution such as "Marshall Excelsior" leak detector.

CAUTION: DO NOT USE THE VALVE IF ANY JOINT CONTINUES TO LEAK UNDER PRESSURE

C. Component List

1. Valve Body
2. Bushing, 10 required
3. Screw, 4 required
4. Washer, 4 required (if applicable)
5. Screen
6. Cap Screw, 8 required
7. Valve Cage
8. Cage Bushing
9. Closing Spring
10. Spring Pin
11. Retainer
12. Excess Flow Spring
13. Stem
14. Valve Holder Assembly
- 14A. Valve Holder
- 14B. Valve Seal
- 14C. Spacer, 4 required
- 14D. Seal Retainer
- 14E. Bolt, 4 required
15. Seat Ring
16. O-Ring
17. Guide Bushing
18. Cotter Pin, 2 required
19. Cam Pin
20. Cam Assembly
- 20A. Cam
- 20B. Roller Pin
- 20C. Roller
- 20D. Roller Bushing
21. Stub Washer
22. Rod Wiper
23. Bonnet
24. Female Adapter
25. V-Pack, 3 required
26. Male Adapter
27. Packing Washer
28. Ejection Spring
29. Packing Spring
30. Stub
31. Stem Bushing
32. Gland Bushing, 2 required

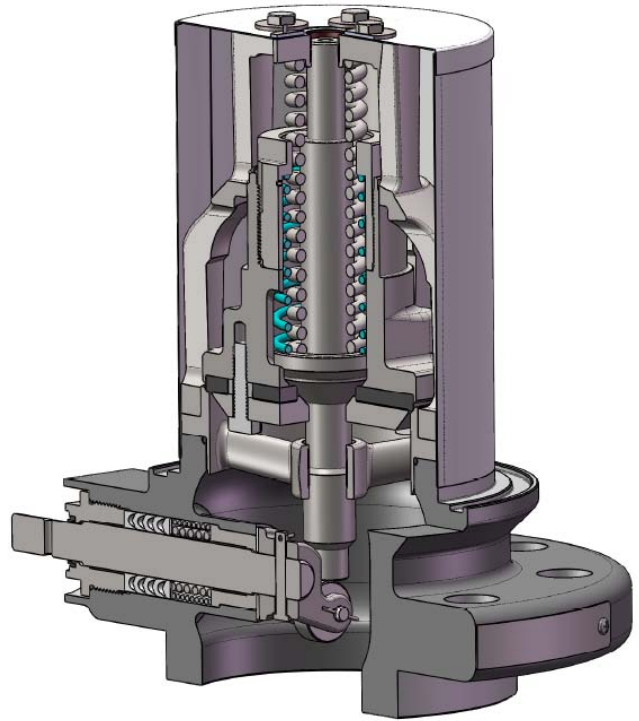

ME990-4F-SRK

