



**ME980-10-901, ME980-16-901,  
AND ME980-24-901  
CLAPPER REPAIR KIT  
FOR: 1 1/4"- 3" EMERGENCY SHUT-OFF VALVE**

**!!!WARNING!!!**

READ AND UNDERSTAND ALL INSTRUCTIONS INCLUDED WITH THIS REPAIR KIT  
RELIEVE ALL PRESSURE FROM SYSTEM BEFORE REMOVING VALVE FOR SERVICE

**MEC recommends that you replace the graphite flange seal, P/N ME980-16-114 or ME980-24-111(not included) when repairing this assembly.**

**NOTE:** Numbers in brackets [ ] refer to the number in the valve component list.

### **A. Disassembly**

- 1. EVACUATE ALL PRESSURE FROM SYSTEM BEFORE ANY DISASSEMBLY OR REPAIR.**
- 2. For ME980-10-901 and ME980-16-901:** Remove (4) Flange Bolts [8] and Flange [2] and retain.  
**For ME980-24-901:** Remove (8) Flange Bolts [8] and Flange [2] and retain.
- 3. For ME980-10-901 and ME980-16-901:** Remove O-Ring [10] and retain. Remove Graphite Flange Seal [4] and discard.  
**For ME980-24-901:** Remove Graphite Flange Seal [4] and discard.
4. Remove Handle Spring Arm [14] from Latch Assembly [18].
5. Remove Handle Screw [16] and Handle Washer [15] from Stem [5] and retain.
6. Remove Spring Retainer [13], Handle Spring, Handle Assembly [22] and Link Bearing [17] and retain.
7. Remove Stem Assembly [21], Gland Spring [12], and Thick Washer [11] and retain.
8. Loosen Arm Holding Screw [9] and remove Pivot Stem [3], Clapper Assembly [19], Pivot Bearing [6], and Stem Bearing [7] from Body [1] and discard Arm Holder Screw and Clapper Assembly and retain

Pivot Stem, Pivot Bearing, and Stem Bearing.

9. Inspect Valve Body [1] and clean if necessary, be sure interior is free of dirt, residue and foreign particles.

### **B. Reassembly**

1. Install Pivot Bearing and Stem Bearing into Body.
2. Install Arm Holding Screw onto Clapper Assembly and install Clapper Assembly into Body.
3. Install Pivot Stem into Body, retaining Clapper Assembly.
4. Tighten Arm Holding Screw securely.
5. Install Thick Washer into Body.
6. Apply Lubriplate to packing bore in Body.
7. Install Gland Spring into Body.
8. Apply loctite #271 to threads of Gland and install Stem Assembly into Body, tighten securely. Confirm that Clapper Assembly moves freely.
9. Install Graphite Flange Seal into Body.
10. **For ME980-10-901 and ME980-16-901 only:** Apply lubriplate to O-Ring and install on Body.
11. **For ME980-10-901 and ME980-16-901:** Apply loctite #271 to threads of Body, place Flange on Body, and install (4) Flange Bolts into Body and tighten in "star" pattern and confirm that all screws are tightened.  
**For ME980-24-901:** Apply loctite #271 to threads of Body, place Flange on Body, and install (8) Flange Bolts into Body and tighten in "star" pattern and confirm that all screws are tightened.
12. Install Link Bearing onto Stem

### **Marshall Excelsior Company**

1506 George Brown Drive Marshall, MI 49068  
Phone (269) 789-6700 Fax (269) 781-8340  
www.marshallexcelsior.com

The contents of this publication are for informational purposes only. While every effort has been made to ensure accuracy, these contents are not to be construed as warranties or guarantees, expressed or implied, regarding the products or services described herein or for their use or applicability. Marshall Excelsior Co. reserves the right to modify or improve the designs or specifications of such products at any time without notice. The MEC™ logo is the trademark of Marshall Excelsior Co.

ME980-10-901, ME980-16-901,  
AND ME980-24-901

13. With Clapper closed, Install Handle Assembly onto Stem with Latch Bearing facing down.
14. Apply loctite #271 to stem threads.
15. Install Thermal Linkage into Handle Arm Assembly.
16. Install Spring Retainer into Thermal Linkage as shown with Handle Spring Arm oriented as shown (Figure 1).
17. Install Handle Washer and Handle Screw, tighten securely.
18. Wind Handle Spring Arm clockwise and attach to Latch Body.
19. Connect the valve assembly outlet to a pressure source of at least 150 PSI. Check for leaks at all joints and stem seals using a suitable leak detector solution such as "Marshall Excelsior" leak detector.

**CAUTION: DO NOT USE THE VALVE IF ANY JOINT CONTINUES TO LEAK UNDER PRESSURE**

**C. Component List**

1. Valve Body
2. Flange
3. Pivot Stem
4. Graphite Flange Seal
5. Stem
6. Pivot Bearing
7. Stem Bearing
8. Flange Bolt
9. Arm Holder Screw
10. O-Ring
11. Thick Washer
12. Gland Spring
13. Spring Retainer
14. Handle Spring
15. Handle Washer
16. Handle Screw
17. Link Bearing
18. Latch Assembly
19. Clapper Assembly
20. Stem Assembly
21. Handle Assembly

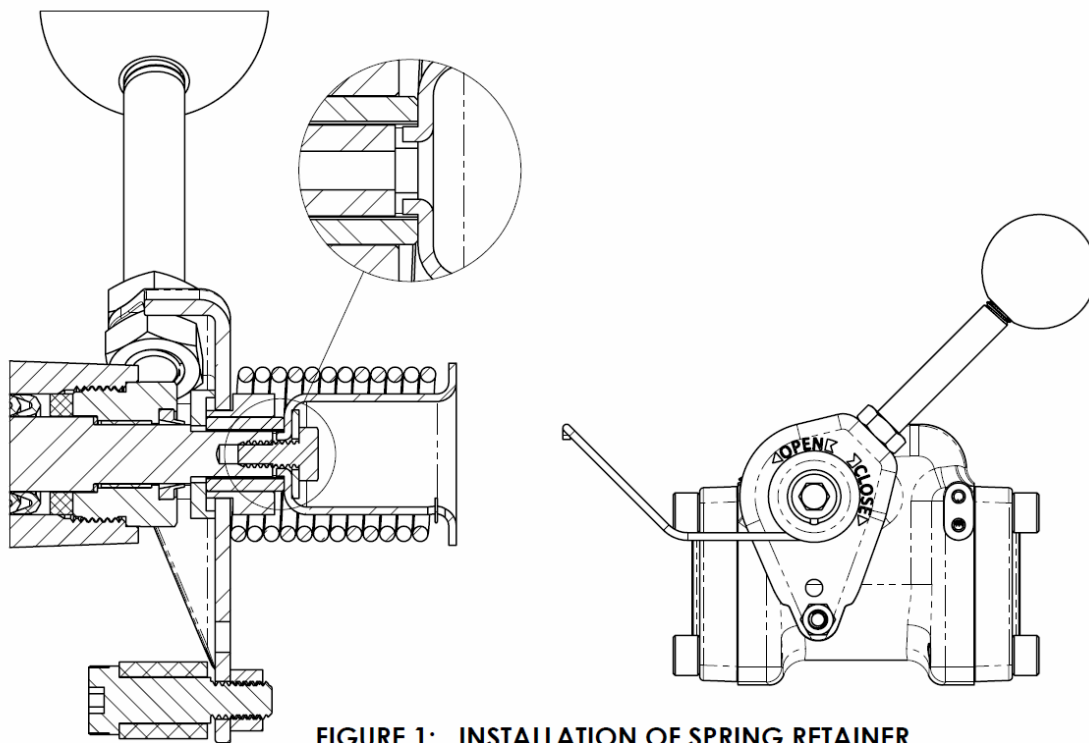

**FIGURE 1: INSTALLATION OF SPRING RETAINER AND HANDLE ARM SPRING**

ME980-10-901, ME980-16-901,  
AND ME980-24-901

