

CAUTION: Handle assembly with care to prevent damage to magnet.

NOTE: Parts are shipped assembled with Anti-Seize on threads to protect threads from damage.

NOTE: MEC recommends removing Trans-Max Liquid Level Mount Gauge prior to hydro testing.

Installation:

1. Remove Outer Wedge, Inner Wedge, and Wedge Shaft Weldment. **Note:** Do not remove anti-seize.

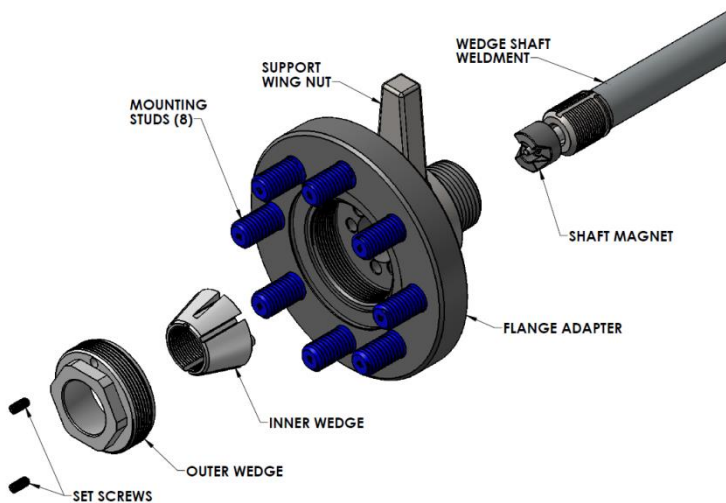

2. Install Wedge Shaft Weldment through tank and Flange Adapter.

Note: Installing Flange Adapter into tank before Step 2 will result in Wedge Shaft Weldment not to fit.

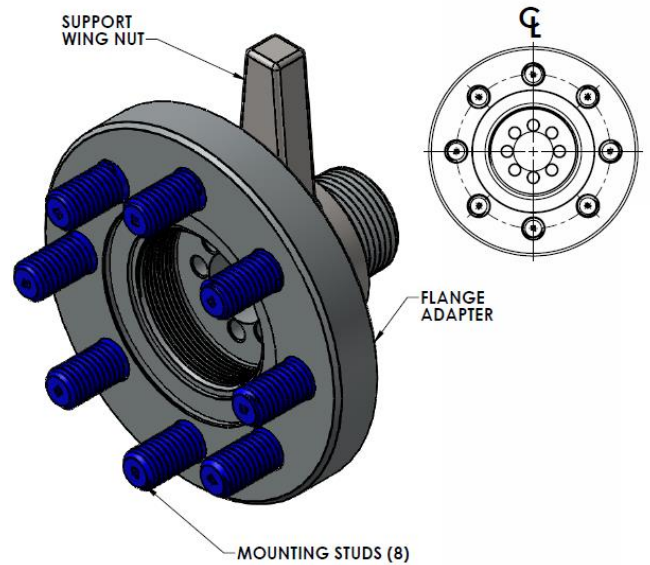

3. Apply a good quality pipe sealant to NPT threads of Flange Adapter. Thread Flange Adapter, with Support Wing Nut fully installed, into tank coupling using MEC installation tool MEP930WG, tighten securely. Centerline mount Flange Adapter. Tighten Support Wing Nut securely using MEC installation tool. Flange must be centerline mount to prevent error

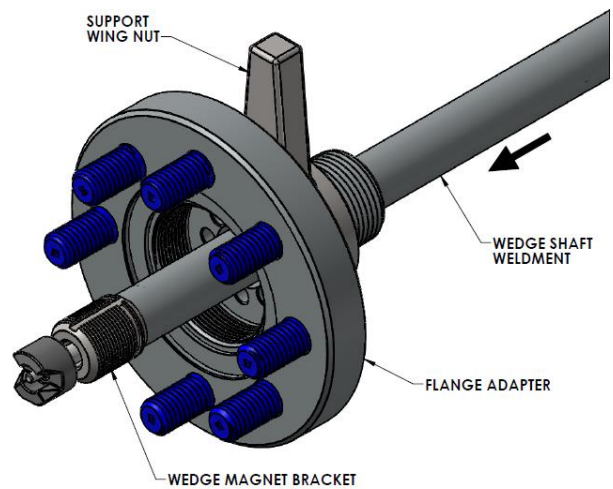

Marshall Excelsior Company
1506 George Brown Drive Marshall, MI 49068
Phone (269) 789-6700 Fax (269) 781-8340
www.marshallexcelsior.com

The contents of this publication are for informational purposes only. While every effort has been made to ensure accuracy, these contents are not to be construed as warranties or guarantees, expressed or implied, regarding the products or services described herein or for their use or applicability. Marshall Excelsior Co. reserves the right to modify or improve the designs or specifications of such products at any time without notice. The MEC™ logo is the trademark of Marshall Excelsior Co.

ME930WG / ME940WG SERIES INSTALLATION GUIDE

4. Install Inner Wedge onto Wedge Shaft Weldment until Inner Wedge stops. Back off Inner Wedge no more than 1 turn so that keyways are aligned.

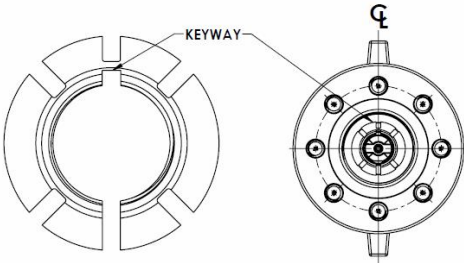
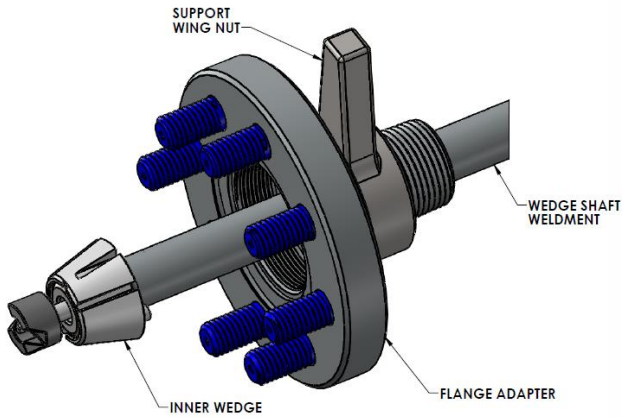

5. Install key until flush with Inner Wedge. Support the float gauge in horizontal position. With keyway facing up, align bosses on Inner Wedge with holes in Flange Adapter and install Inner Wedge into Flange Adapter.

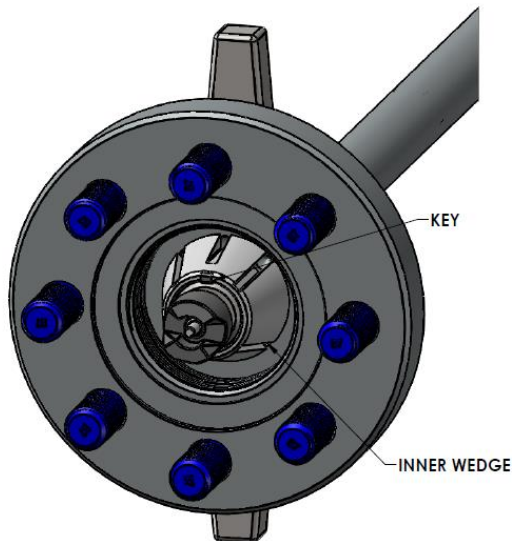

6. Install Outer Wedge into Flange Adapter and tighten securely. Tighten Set Screws securely.

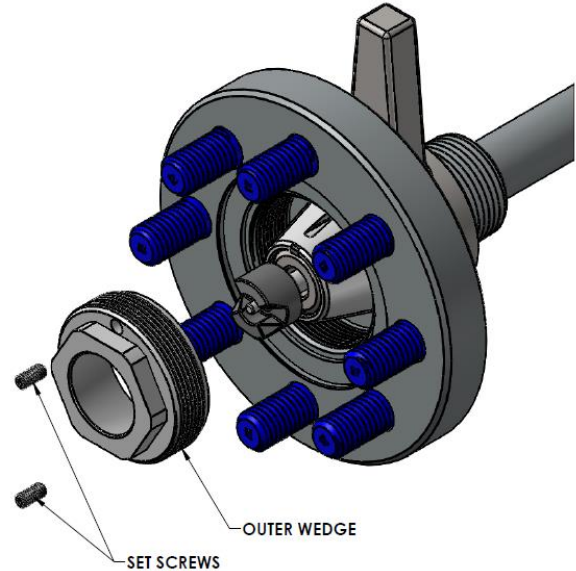

7. Assemble remaining parts as specified in Marshall Excelsior's "Accu-Max Liquid Level Gauges ME930 / ME940 Series Installation Guide". **Except as Follows:**
- Tighten Mounting Flange until it is in full contact with Flange Adapter.
 - If gauge must be installed during hydro testing, remove Mounting Flange after hydro test to drain water.

