

!!!WARNING!!!

READ AND UNDERSTAND ALL INSTRUCTIONS INCLUDED WITH THIS REPAIR KIT
RELIEVE ALL PRESSURE FROM SYSTEM BEFORE REMOVING VALVE FOR SERVICE

VALVE REPAIR INSTRUCTIONS

NOTE: Numbers in brackets [] refer to the number in the valve component list.

A. Disassembly

1. **EVACUATE ALL PRESSURE FROM SYSTEM BEFORE ANY DISASSEMBLY OR REPAIR.**
2. Remove Cap [12] on top of Bonnet [2] and retain.
3. Turn Adjusting stem [11a] counter clockwise until it stops to relieve Spring [4].
4. Remove 4 Bolts [14] and discard.
5. Remove Bonnet [2] from Body [1].
6. Remove and discard Valve Stem Assembly [11] and Washer [10] from Bonnet [2].
7. Remove and retain Spring [4], and discard Valve [3], and all Seals [6, 7 & 8] from Body [1].
8. Inspect Valve Body [1], and clean if necessary, be sure interior is free of dirt, residue and foreign particles.
CAUTION: Do not SCRATCH or MARK seat area in valve body.

B. Reassembly

1. Apply silicone grease to new O-rings [6 & 7] and Cap Seal [8]
2. Place O-ring [7] into lower groove in body [1].
3. Place second O-ring [7] over Cap Seal [8] and place Assembly into Body [1] as shown.
4. Place new Valve [3] into Body [1] as shown
5. Place new Flange O-ring Seal [6] in Valve Body [1] as shown
6. Thread Spring Retainer [11b] all the way towards o-rings [5] on Stem Assembly [11] and insert Stem Assembly [11] into Bonnet [2]

7. Place Spring [4] into Valve [3] as shown
8. Place assembled Bonnet [2] onto Body [1] with Nameplate [9] facing inlet and thread 4 Bolts [14] into Body [1] retaining Bonnet [2].

Connect the valve assembly outlet to a pressure source of at least 150 PSI. Check for leaks at all joints and Stem seals using a suitable leak detector solution such as "Marshall Excelsior" leak detector.

CAUTION:
DO NOT USE THE VALVE IF ANY JOINT CONTINUES TO LEAK UNDER PRESSURE.

9. Re-adjust set point for Valve and Thread Cap [12] onto Bonnet [2].

Valve Component List

1. Body
2. Bonnet
3. Valve
4. Spring
5. O-Ring, 2 required
6. O-Ring
7. O-Ring, 2 required
8. O-Ring Cap Seal
9. Nameplate (not shown)
10. Washer
11. Stem Weldment
- 11a. Stem
- 11b. Retainer
- 11c. Washer
- 11d. Dowel Pin, 2 required (not shown)
12. Cap
13. Nameplate screw, 2 required (not shown)
14. Bonnet Bolt, 4 required
15. 1/4" NPT Plug, 2 required (not shown)

Marshall Excelsior Company

1506 George Brown Drive Marshall, MI 49068
Phone (269) 789-6700 Fax (269) 781-8340
www.marshallexcelsior.com

ME840-24K
VALVE REPAIR KIT
FOR ME840-24 SERIES VALVE ASSEMBLY

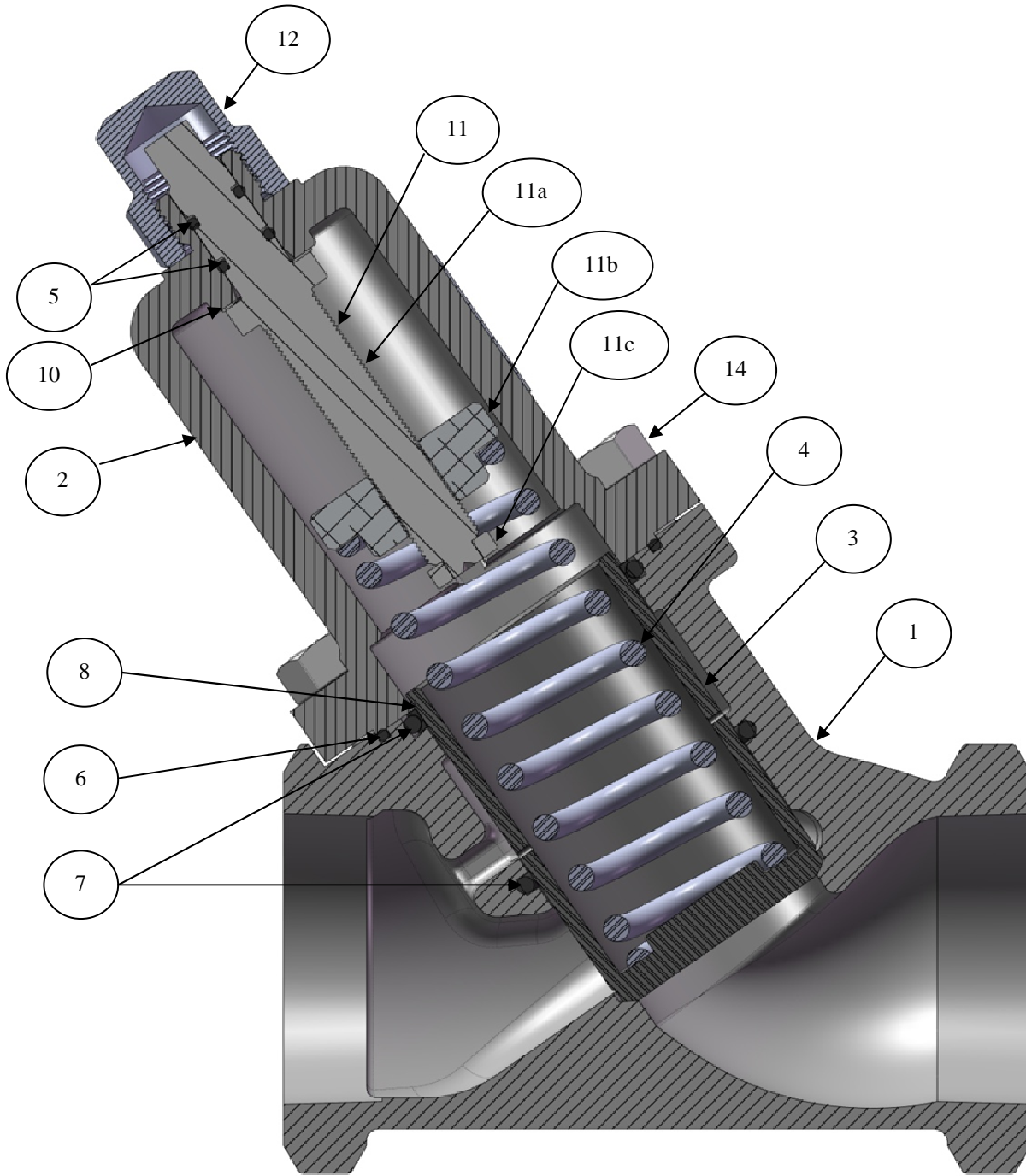

Marshall Excelsior Company
1506 George Brown Drive Marshall, MI 49068
Phone (269) 789-6700 Fax (269) 781-8340
www.marshallexcelsior.com

The contents of this publication are for informational purposes only. While every effort has been made to ensure accuracy, these contents are not to be construed as warranties or guarantees, expressed or implied, regarding the products or services described herein or for their use or applicability. Marshall Excelsior Co. reserves the right to modify or improve the designs or specifications of such products at any time without notice. The MEC™ logo is the trademark of Marshall Excelsior Co.