

(214) 357-4591 DALLAS TEXAS (800) 345-8105

MANUFACTURED BY PARKER PGI

# Installation, Operation & Maintenance Manual for Flo-Max II Coupler Model FM150

October 2014

Form FVC 078 - Rev 08

**IMPORTANT: KEEP THIS DOCUMENT WITH THE PRODUCT UNTIL IT REACHES THE END USER.**

1. Contact with or inhalation of Liquid Anhydrous Ammonia (NH<sub>3</sub>) or of LP Gas can cause **SERIOUS INJURY OR DEATH**.
2. Before installation or removal of any tank valve, the system must be purged of all product.
3. Personal Protective Equipment (PPE), safety gloves, goggles and clothing should be worn.
4. For proper handling and storage of NH<sub>3</sub>, and Liquefied Petroleum Gas refer to ANSI Standard K61.1 and NFPA Pamphlet 58.
5. An abundant supply of fresh water should be available to provide immediate first aid treatment for exposure to NH<sub>3</sub> and LP-Gas.
6. To prevent the accidental opening of any valve, never grasp or carry a valve by its Hand wheel or handle.
7. To ensure long term safe operation, the manufacturer recommends that under normal service conditions this product should be inspected at least once every year and be repaired or replaced as required.

**TOOLS REQUIRED:** Safety Equipment (i.e. gloves, goggles, and clothing), 12" Adjustable Wrench, 7/16" Open End Wrench, and 12" Pipe Wrench.

The Flo-Max II coupler is designed to disconnect the nurse tank hose from a tool bar before the straight pull force on the hose exceeds 600 pounds. Upon disconnect, swing checks in both halves of the coupler snap closed to stop flow of product from the nurse tank or the tool bar.

**WARNING!** FAILURE TO READ AND UNDERSTAND THE INSTRUCTIONS CONTAINED IN THIS INSTALLATION, OPERATION AND MAINTENANCE MANUAL CAN LEAD TO PROPERTY DAMAGE AND SERIOUS INJURY OR DEATH.

If you have any questions about anything contained in this manual or desire additional copies, please call Squibb Taylor at 1-800-345-8105 and ask for customer service.

**WARNING!** PROPER OPERATION OF THIS DEVICE AND YOUR SAFETY DEPENDS ON THE FOLLOWING:

1. **The mounted coupler must be able to freely swivel approximately 80 degrees to each side AND about 30 degrees up and down.** This must be done so the coupler will be presented with a straight pull by the hose in the event of a situation where the nurse tank comes free of its attachment to the tool bar. If the coupler cannot swivel properly, the hose may pull at an angle which causes the separation force to increase greatly and may bind the coupler preventing separation. **Since pull away events often occur in a turn, the ability of the coupler to swivel as described is critical to operation of this device.**
2. **All piping and valves in the system should be able to withstand a pull force greater than 600 lbs.**
3. **The female part of the coupler that is attached to the swivel bracket must be able to move at least 1/3 inch toward the bracket to compress the latch spring to allow unlatching of the coupler in the event of a pull away.** The hose and fittings attached to the coupler at the swivel bracket must not catch on anything that would prevent movement of the coupler toward the bracket during a pull away, otherwise the coupler will not separate.
4. **The latch spring cavity must be kept free of any objects that would prevent compression of the latch spring in a pull away.** A rubber cover is provided for this purpose and should be replaced if damaged or missing.
5. **Manually connect and disconnect this device before every usage season. Verify closure and full movement of swing checks and inspect for corrosion debris, binding or any other obstruction and replace or repair as required.** Since all metal surfaces in working contact are corrosion-free stainless steel, no change out date is required as long as the unit is inspected before every usage season.
6. **In a pressurized pull away situation, approximately 125 cc of liquid NH<sub>3</sub> will be released from between the swing checks.**
7. **WARNING!**
  - **Contact with NH<sub>3</sub> liquid or inhalation of NH<sub>3</sub> vapors can cause serious injury or death.**
  - **Protective clothing, goggles and gloves must be worn at all times.**
  - **Emergency water must be available to flood any NH<sub>3</sub> contact area on the body.**

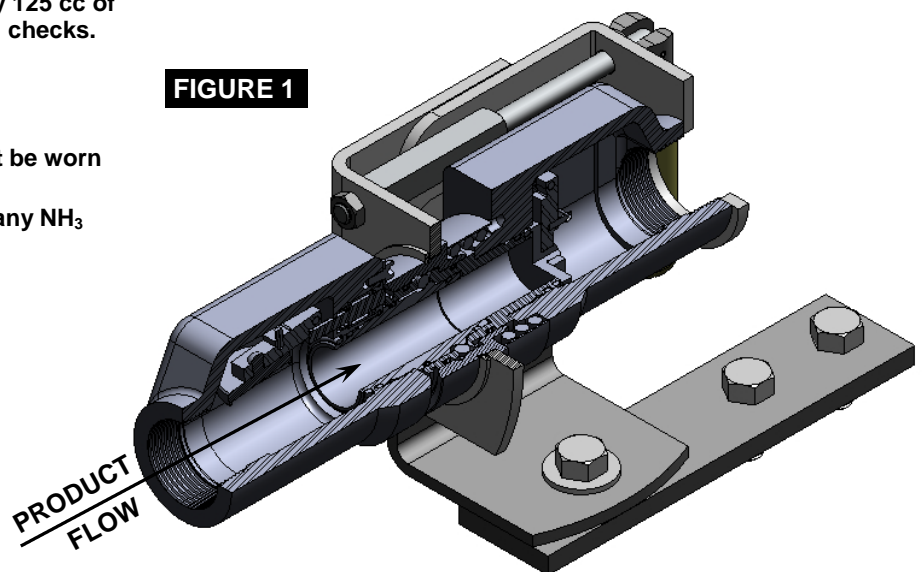
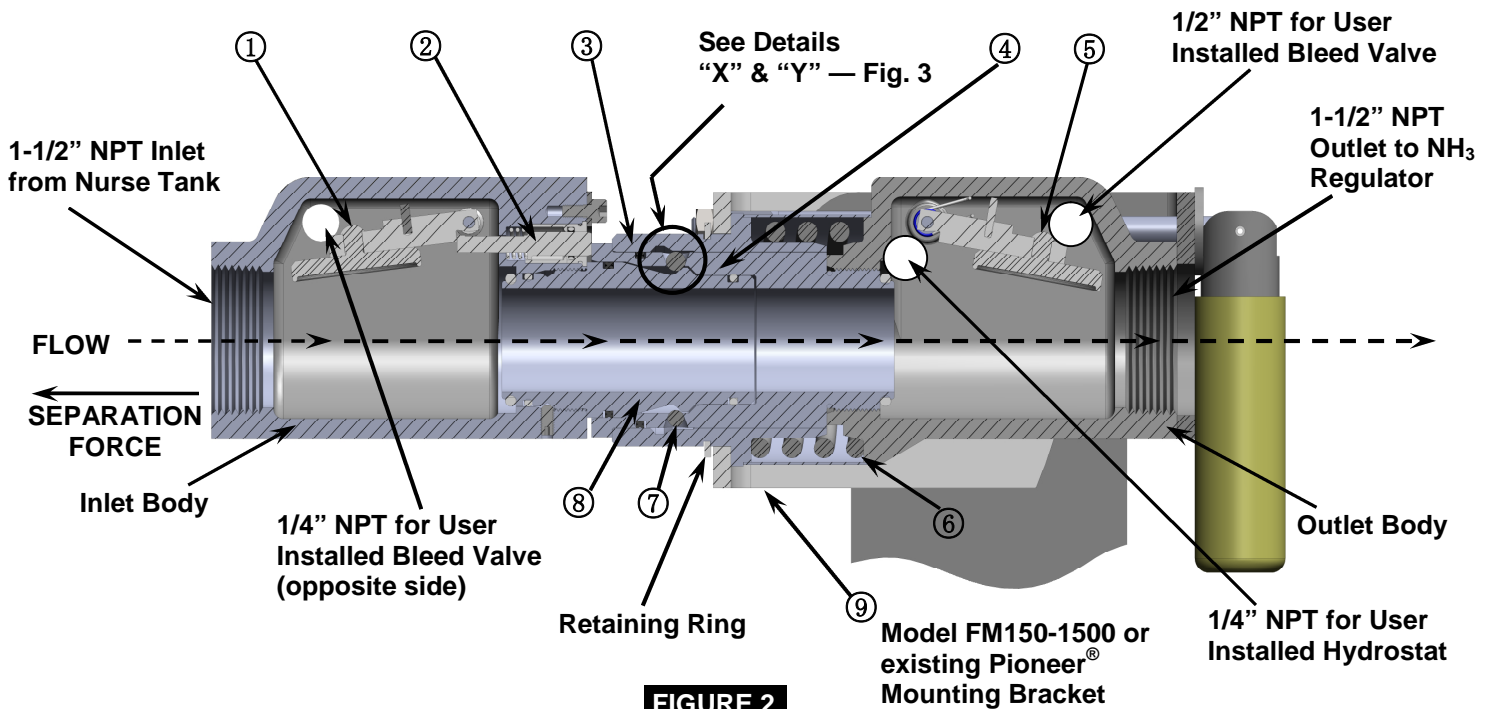

**FIGURE 1**

*While this information is presented in good faith and believed to be accurate, Individuals using this literature must exercise their independent judgment in evaluating product selection and determining product appropriateness for their particular purpose, system requirements and certifications. The manufacturer reserves the right to change product designs and specifications without notice.*

**Operation Instructions (Refer to Figures 2 & 3)**

1. When the Flo-Max II Coupler is engaged and under pressure, the spring-biased Inlet Swing Check ① is held open by the Plunger ②. The spring-biased Outlet Swing Check ⑤ will be opened when NH<sub>3</sub> flow begins.



**FIGURE 2**

2. When fully engaged, the Male Plug ⑧ is secured to the Female Socket ④ by six Latch Balls ⑦. The separation of the Plug from the Socket is accomplished when, and only when, the nurse tank hose becomes taut and is in a straight line pull with the Flo-Max II Coupler.
3. When a separation force is applied to the Male Plug, the Trigger ③ remains stationary since it is attached to the Mounting Bracket ⑨. The Latch Balls, being pulled by the Plug, force the Outlet Body to compress the Trigger Spring ⑥. With about 1/4\" of travel, the Latch Balls are forced into the release groove, allowing a full disconnect. After separation, the Outlet Body will return to the “engaged” position and remain intact in the mounting bracket. The Inlet and Outlet Swing Checks will seal and prevent additional NH<sub>3</sub> release to the atmosphere, as shown in Figure 4.

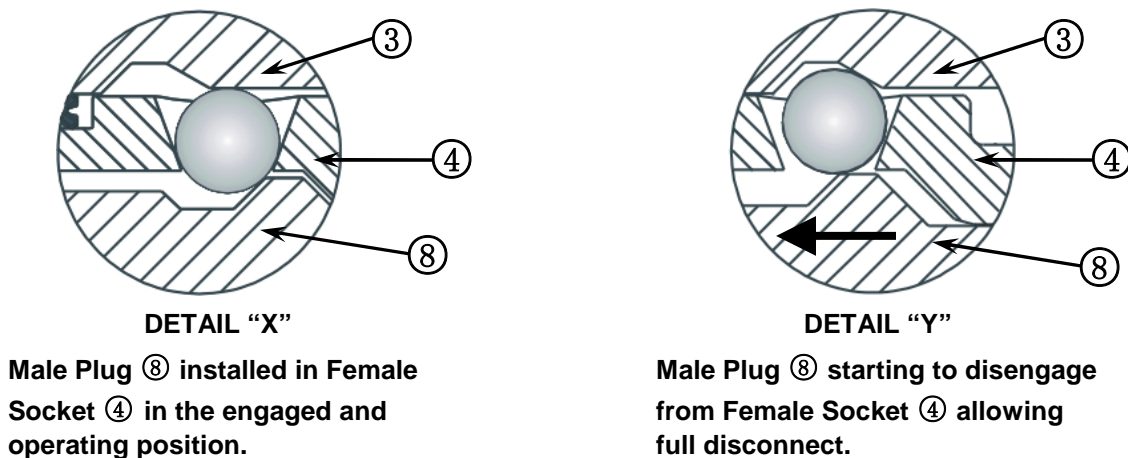

**FIGURE 3**

*While this information is presented in good faith and believed to be accurate, Individuals using this literature must exercise their independent judgment in evaluating product selection and determining product appropriateness for their particular purpose, system requirements and certifications. The manufacturer reserves the right to change product designs and specifications without notice.*

Operation Instructions (Refer to Figure 4)

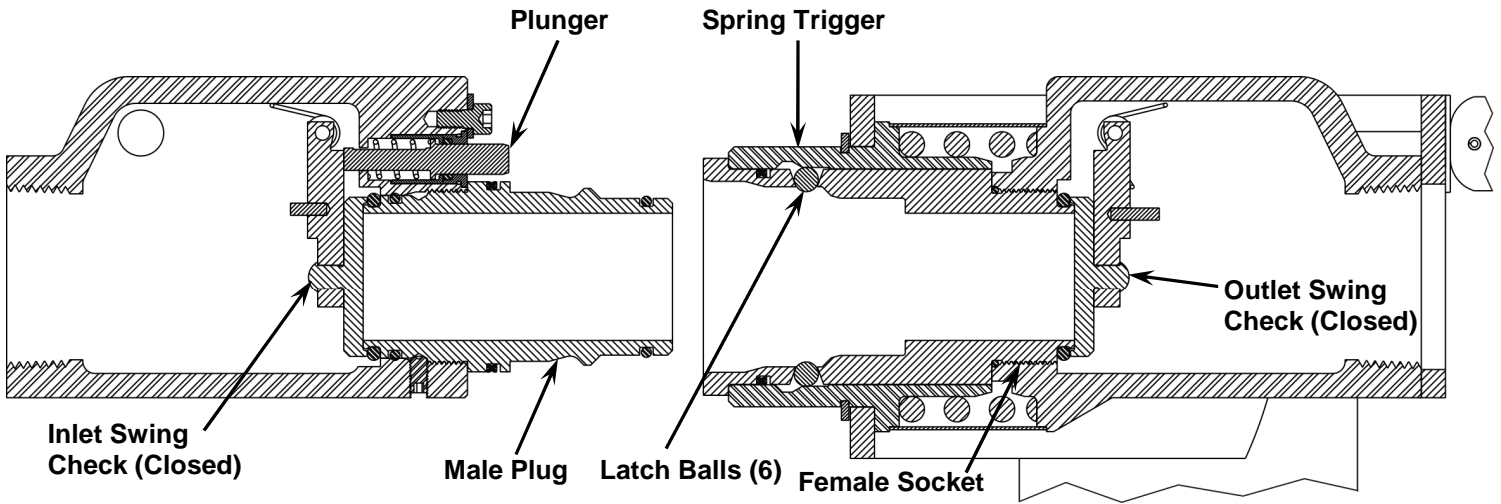

**FIGURE 4**

**When separation occurs . . .**

- the Male Plug is completely disengaged from the Female Socket and remains with the nurse tank hose.
- the Inlet Swing Check is no longer forced open by the Plunger, and is free to seal the flow path from the nurse tank.
- the Outlet Body remains with the tool bar.
- the Outlet Swing Check is no longer forced open by flow and closes to prevent release of NH<sub>3</sub> from the tool bar hoses and piping.

**WARNING!**

**NEVER TAMPER WITH THE SWING CHECK OUTER PINS! IF THESE PINS ARE REMOVED, THE UNIT MUST BE RETURNED TO THE FACTORY FOR RE-ASSEMBLY!**

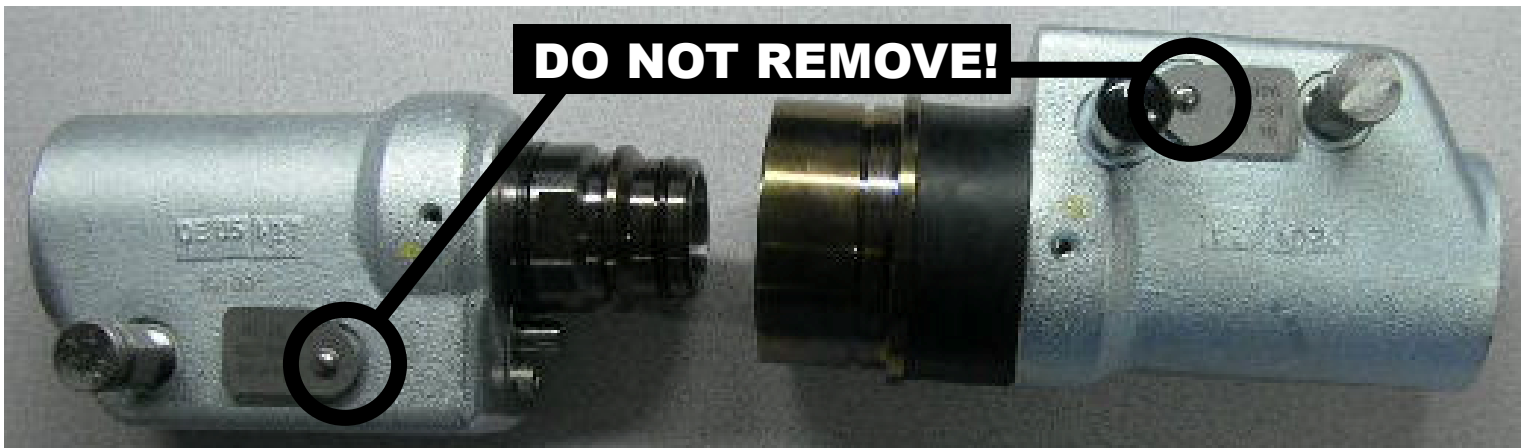

*While this information is presented in good faith and believed to be accurate, Individuals using this literature must exercise their independent judgment in evaluating product selection and determining product appropriateness for their particular purpose, system requirements and certifications. The manufacturer reserves the right to change product designs and specifications without notice.*

## Flo-Max II Coupler Installation Instructions

1. Install a Bleed Valve into the 1/4" NPT on Inlet Body portion of the Coupler. Open the Bleed Valve and leave it open until after the Inlet Body is coupled with the Outlet Body.

Install 1/4" NPT Bleed Valve at this location.

**OPEN THE BLEED VALVE.**



2. Install a 1/4" NPT Hydrostat Fitting into the forward port on the Outlet Body and a Bleed Valve into the rear port on the Outlet Body. These components MUST be installed at the locations shown at right.

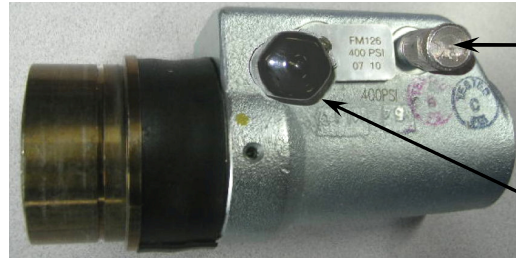

Install 1/4" NPT Bleed Valve at this location.

Install 1/4" NPT Hydrostat Fitting at this location.

3. Attach the nurse tank hose to the Male (Inlet) Half of the Flo-Max II Coupler. Always place the wrench on the body portion of the coupler when connecting or disconnecting a hose.

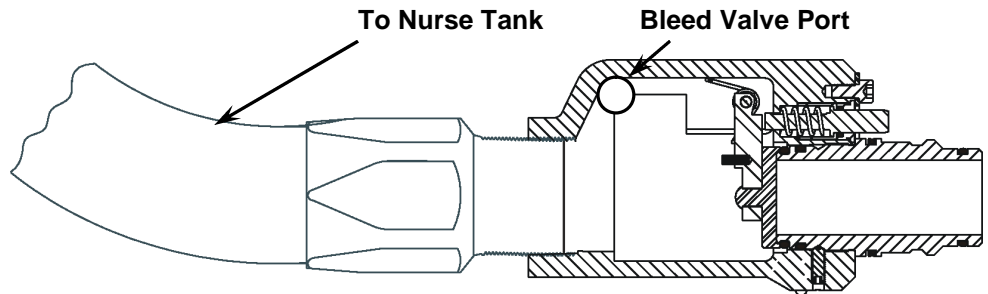

4. Connect the Female (Outlet) Half of the Flo-Max II Coupler to any NH<sub>3</sub> tool bar regulator with the proper hose length. Always place the wrench on the body portion of the coupler when connecting or disconnecting a hose. See FIGURE 8-SAFE INSTALLATION photo on page 5 for minimum parameters for hose length.

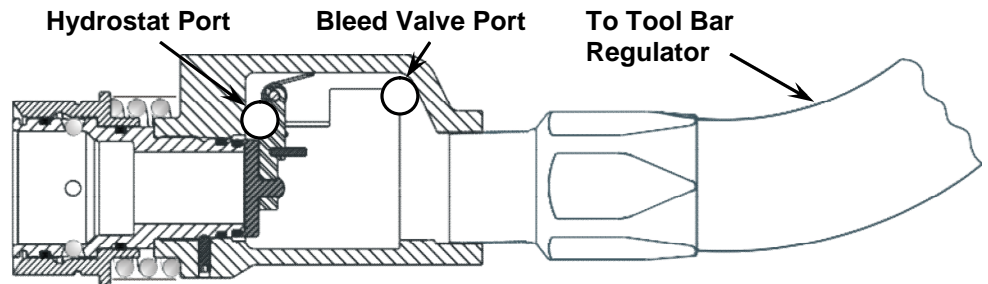

**FIGURE 5**

5. Insert the Spring Trigger through the Mounting Bracket so that the Snap Ring groove is exposed on the opposite side and install the Retaining Ring.

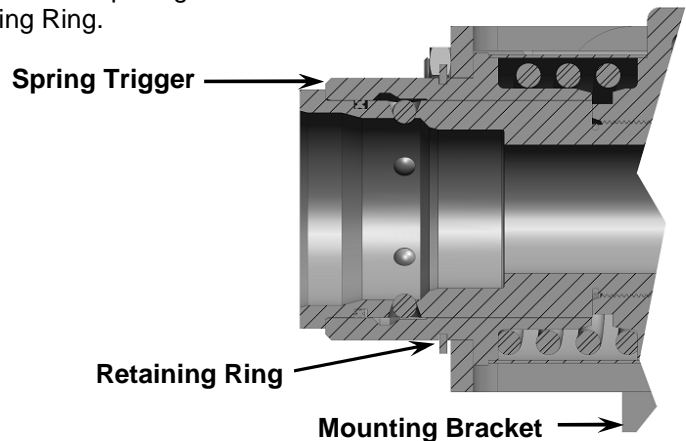

**FIGURE 6**

*While this information is presented in good faith and believed to be accurate, Individuals using this literature must exercise their independent judgment in evaluating product selection and determining product appropriateness for their particular purpose, system requirements and certifications. The manufacturer reserves the right to change product designs and specifications without notice.*



## BRACKET INSTALLATION INSTRUCTIONS

It is mandatory that the Flo-Max II Coupler be installed into a mounting bracket that allows the Coupler full freedom to always, and under any condition, align itself for a straight line pull from the nurse tank hose. The Squibb-Taylor Model FM150-1500 Mounting Bracket provides this freedom of motion and is available through your local distributor. It is also mandatory that the Flo-Max II Coupler and mounting bracket assembly be mounted on the tool bar at a location that will ensure the nurse tank hose will not be pinched or restricted from full movement freedom during operation.

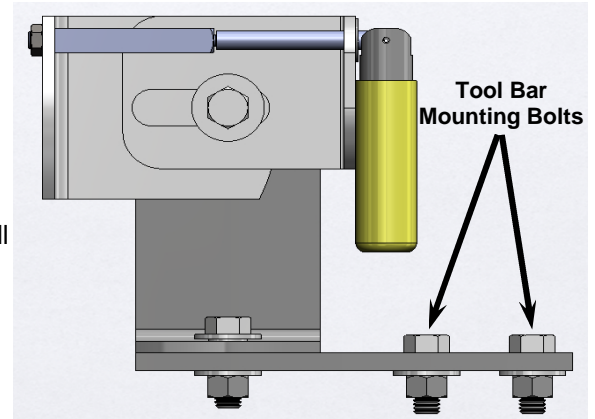

**FIGURE 7**

### **WARNING:**

Improper constraint of an Flo-Max II Coupler outlet hose can cause a **SERIOUSLY UNSAFE CONDITION**.

## REFER TO FIGURE 8 - SAFE INSTALLATION

Figure 8 specifies the minimum outlet hose constraint parameters to assure safe rotation of the Flo-Max II Coupler.

The outlet hose must have a minimum height of 25 inches and must not be tied down or restricted for at least 4.5 feet from the mounting bracket holding the Flo-Max II Coupler.

If these minimum parameters are met, the coupler will have ample slack in the outlet hose to allow the coupler to swivel freely and separate properly in the event of a pull-away.

## SAFE INSTALLATION

### **WARNING!**

Install a **Hydrostat relief valve** and **Bleed Valves** in the ports provided.

The outlet swing check of the Flo-Max II will automatically close when flow stops.

When flow has stopped and the outlet swing check is closed,  $NH_3$  will be trapped between the Flo-Max II outlet and the hydraulic or electric  $NH_3$  shutoff valve when the shutoff valve is closed.

Hydrostat Relief Valve and Bleed Valves are not included.

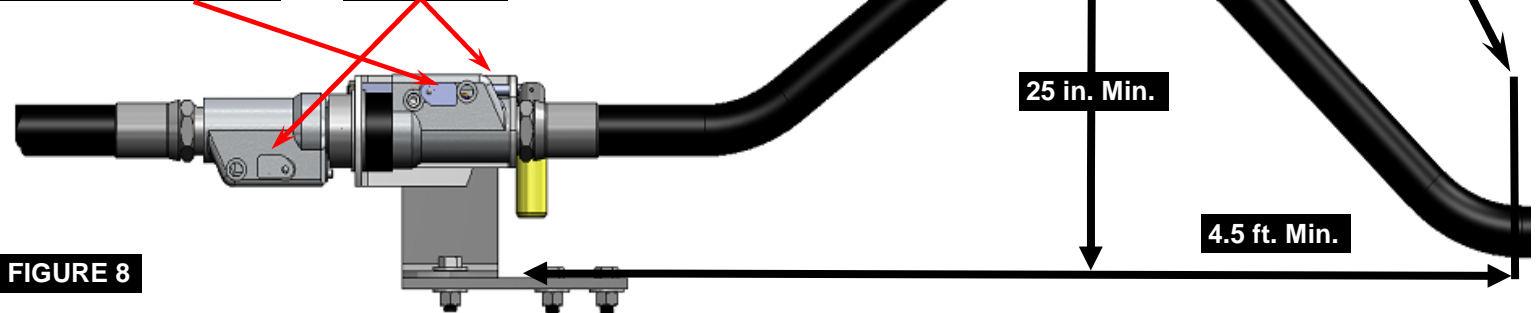

**FIGURE 8**

### **WARNING!**

Verify proper coupler installation after the outlet hose is connected to the metering system and the inlet hose is connected to the nurse tank by gripping the nurse tank hose at least 3 feet from the coupler and move the hose approximately 80 degrees right and left of the center and 30 degrees up and down from horizontal. The coupler should be able to freely swivel to each of these four positions and remain in straight alignment with the nurse tank hose. In each of the four positions, the assembly should be able to withstand a pull force of 600 pounds without bending or breaking the coupler bracket or coupler bracket mounting support on the tool bar. Check to be sure that there are no obstructions that might interfere with free movement of the coupler. If two couplers are installed on a tool bar, each one should be able to pass this test when both couplers are fully installed and connected.

*While this information is presented in good faith and believed to be accurate, Individuals using this literature must exercise their independent judgment in evaluating product selection and determining product appropriateness for their particular purpose, system requirements and certifications. The manufacturer reserves the right to change product designs and specifications without notice.*

## FLO-MAX II COUPLER INSTALLATION INSTRUCTIONS (CONT'D.)

6. **MAKE SURE THE BLEED VALVE IS OPEN**, then insert the Male Plug into the Female Socket as far as possible using only hand pressure.

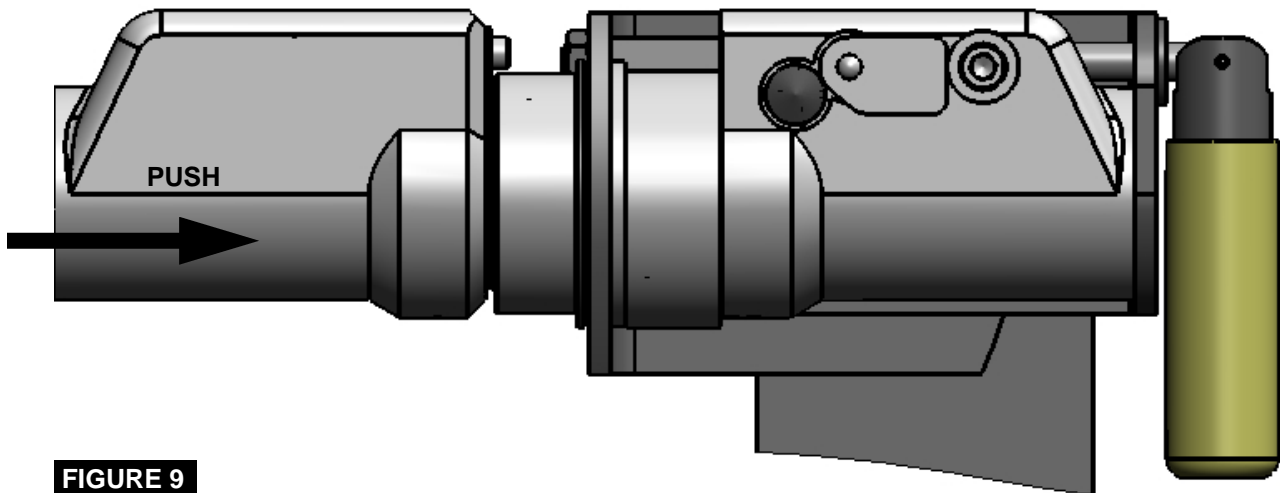

**FIGURE 9**

7. Screw the handle in until it's snug with washer/bracket to engage the handle with the bracket. Actuate cam action by pivoting the bracket handle 80-90 degrees as shown in Figure 10. Hold in this position and push the Male Plug in, which will allow the Male Plug to move to its operating position and the Latch Balls to engage.

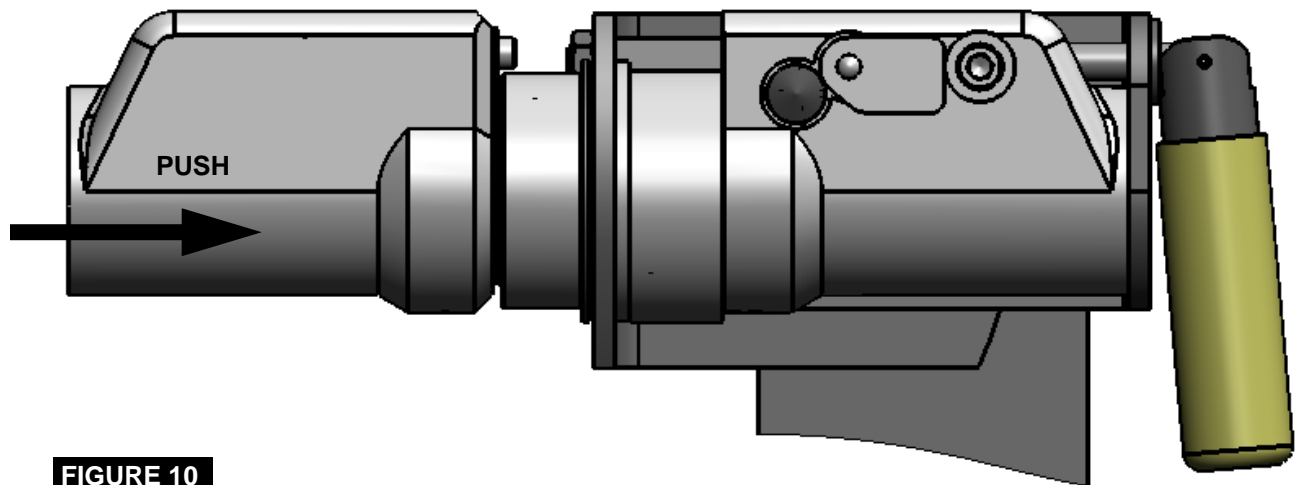
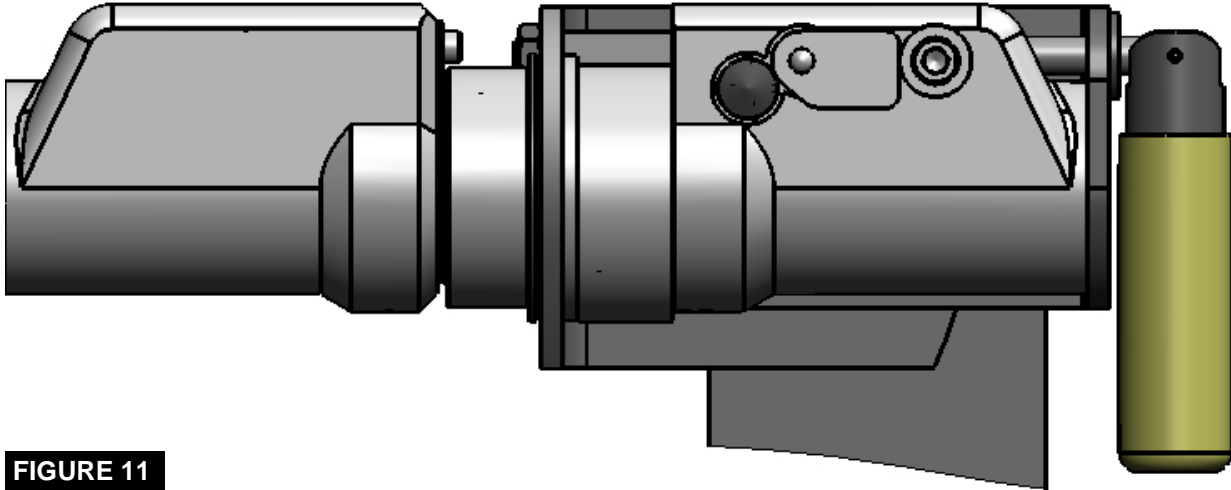

**FIGURE 10**

*While this information is presented in good faith and believed to be accurate, Individuals using this literature must exercise their independent judgment in evaluating product selection and determining product appropriateness for their particular purpose, system requirements and certifications. The manufacturer reserves the right to change product designs and specifications without notice.*

## FLO-MAX II COUPLER INSTALLATION INSTRUCTIONS (CONT'D.)

- Once the male plug is fully engaged, return the handle to the horizontal position to lock the coupler halves together. Pull the Male Half to make sure the latch is engaged. Rotate the bracket handle 5-6 turns counter clockwise so that it is no longer in the contact with the bracket and let it hang freely as shown in Figure 11. This is normal operating condition and will ensure the coupler will not disengage accidentally.



**FIGURE 11**

- GRASP THE SUPPLY HOSE AND MAKE SURE THE Flo-Max II MOUNTING BRACKET CAN FREELY MOVE 80° RIGHT, 80° LEFT, 30° UP AND 30° DOWN, AS A MINIMUM.**  
See FIGURE 8 - SAFE INSTALLATION.
- Manually disconnect the coupler as described on page 11 to verify proper installation.**
- Reconnect the coupler as described in steps 1-10 below.
- CLOSE ALL BLEED VALVES.**
- Open valves according to applicator manufacturer's instructions when ready to apply NH3.

## RECONNECTION AFTER SEPARATION

**Before attempting to reconnect the Coupler:**

- CLOSE ALL VALVES AND INSPECT ALL HOSES, VALVES AND FITTINGS FOR PROPER CONDITION.**
- OPEN THE BLEED VALVE ON THE MALE HALF TO RELIEVE PRESSURE IN THE NURSE TANK HOSE. LEAVE THE BLEED VALVE OPEN.**  
**NOTE:** Pressure may be trapped in the Female Half, but the Coupler may still be reconnected.

### **WARNING!**

**THE BLEED VALVE MUST BE LEFT OPEN TO PREVENT RESIDUAL LIQUID FROM RE-PRESSURING THE HOSE.**

## RECONNECTION AFTER SEPARATION (CONT'D.)

3. Inspect the Male Half of the Flo-Max II Coupler by depressing the Plunger to make sure it operates freely and the Swing Check returns to the closed position when the Plunger is released.

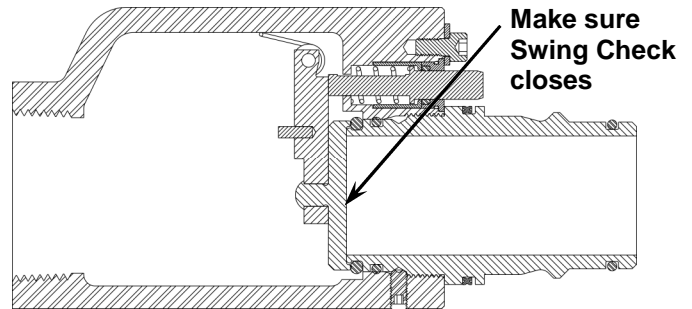
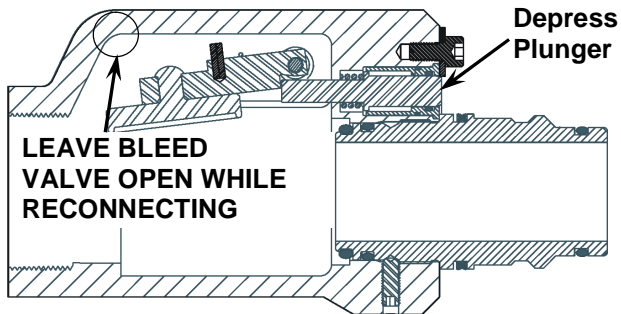

4. Wipe the outside of the Male Plug with a clean cloth to remove any dirt and debris from the Main Seal O-Ring and Environmental Seal Quad Ring.

Inspect the O-Rings and replace them if damaged. See Service Kit Figure 17 and 18.

### WARNING!

IN THE EVENT OF A FORCED DISCONNECT, THE MAIN SEAL MAY BE BLOWN OUT OF ITS GROOVE, BUT WILL REMAIN ON THE MALE PLUG. BE SURE TO CLEAN AND INSPECT THE MALE PLUG AND THE O-RING, AND RE-INSTALL THE O-RING IN ITS PROPER LOCATION AS SHOWN BELOW AT ①.

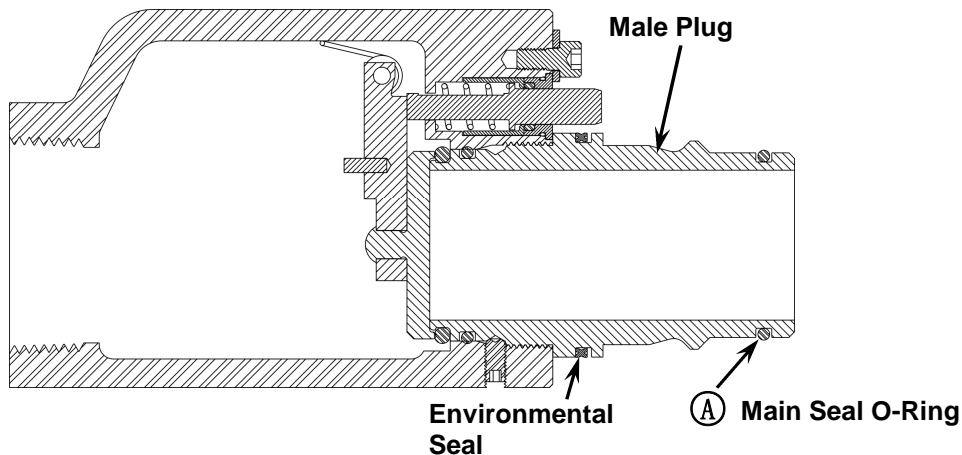

While this information is presented in good faith and believed to be accurate, Individuals using this literature must exercise their independent judgment in evaluating product selection and determining product appropriateness for their particular purpose, system requirements and certifications. The manufacturer reserves the right to change product designs and specifications without notice.



## RECONNECTION AFTER SEPARATION (CONT'D.)

5. **Make sure the Bleed Valve is open**, then insert the Male Plug into the Female Socket as far as possible using only hand pressure. As shown in Figure 12.

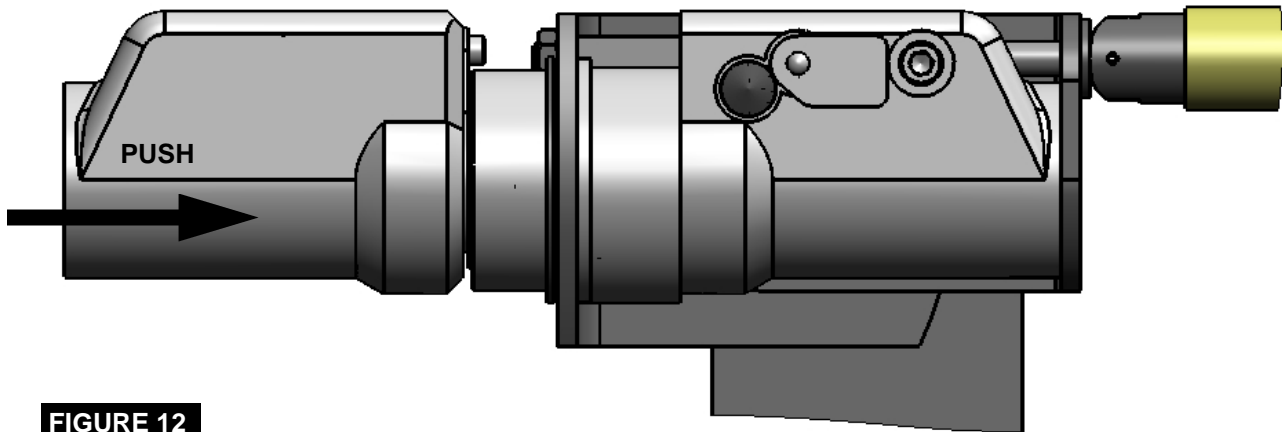

**FIGURE 12**

6. Screw the handle in until its snug with washer/bracket to engage the handle with the bracket. Actuate cam action by pivoting the bracket handle 80-90 degrees, as shown in figure 13, push the Male Plug in, which will allow the Male Plug to move to its operating position and the Latch Balls to engage.

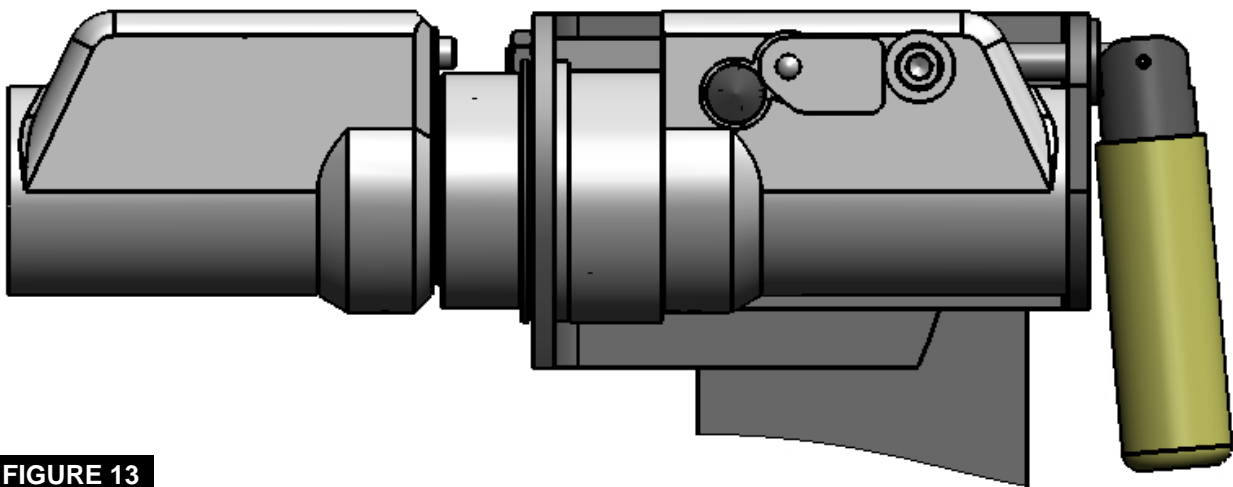
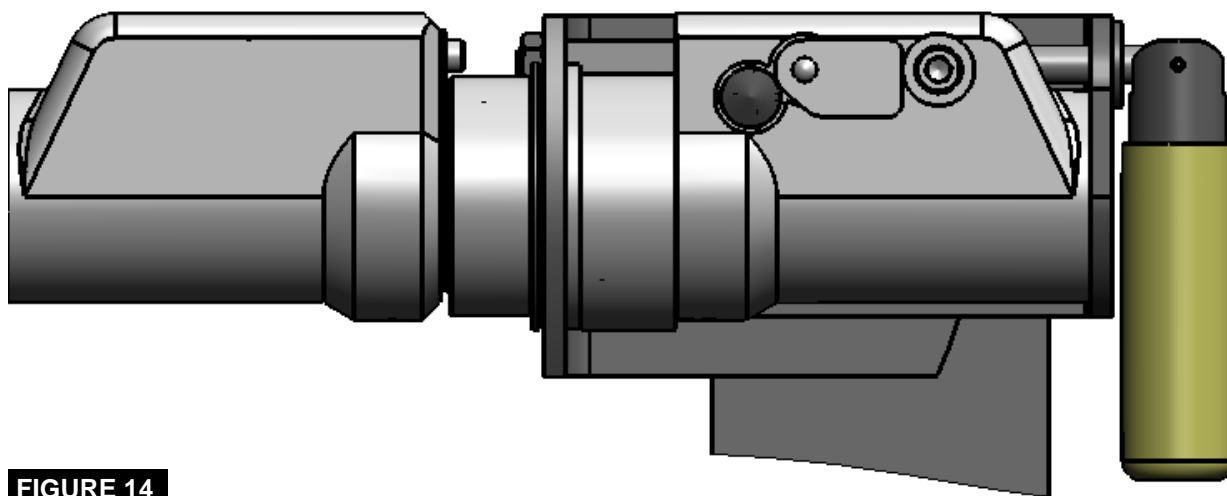

**FIGURE 13**

*While this information is presented in good faith and believed to be accurate, Individuals using this literature must exercise their independent judgment in evaluating product selection and determining product appropriateness for their particular purpose, system requirements and certifications. The manufacturer reserves the right to change product designs and specifications without notice.*

## RECONNECTION AFTER SEPARATION (CONT'D.)

7. Once the male plug is fully engaged, return the handle to the horizontal position to lock the coupler halves together. Pull the Male Half to make sure the latch is engaged. Rotate the bracket handle 5-6 turns counter clockwise so that it is no longer in the contact with the bracket and let it hang freely as shown in Figure 14. This is normal operating condition and will ensure the coupler will not disengage accidentally.



**FIGURE 14**

8. **GRASP THE SUPPLY HOSE AND MAKE SURE THE Flo-Max MOUNTING BRACKET CAN FREELY MOVE 80° RIGHT, 80° LEFT, 30° UP AND 30° DOWN, AS A MINIMUM.**  
**See FIGURE 8 - SAFE INSTALLATION.**
9. CLOSE ALL BLEED VALVES.
10. Open valves according to applicator manufacturer's instructions when ready to apply NH<sub>3</sub>.

### **DANGER!**

**It is imperative that all pressure is removed from the inlet side of the coupling before separating the coupler manually.**

**USE EXTREME CAUTION!**

**A 125 cc liquid release of NH<sub>3</sub> will occur from the internal cavity of the Flo-Max II Coupler when separated.**

**Serious bodily harm could result if the coupler is separated while under pressure.**

MANUAL DISCONNECT INSTRUCTIONS (REFER TO FIGURE 15)

1. CLOSE THE NURSE TANK WITHDRAWAL VALVE.
2. OPEN THE BLEED VALVE ON THE MALE HALF TO RELIEVE PRESSURE IN THE NURSE TANK HOSE. LEAVE THE BLEED VALVE OPEN.  
NOTE: Pressure may be trapped in the Female Half, but the Coupler may still be reconnected.
3. Screw the EZ Bracket handle in until it is snug with the washer/bracket to engage the handle with the bracket as shown in Figure 15. Actuate the cam action on the handle by pivoting the bracket handle 80-90 degrees as shown in Figure 16.

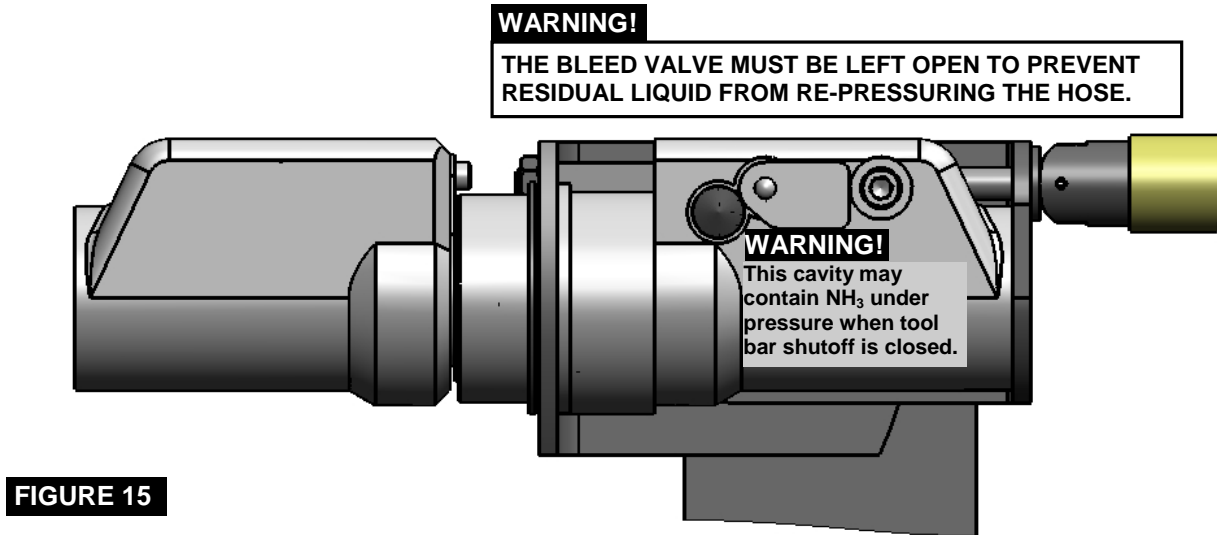

4. The cam action will compress the Trigger Spring and allow the Latch Balls to be disengaged and the male half of the coupler can be disconnected from the female half.

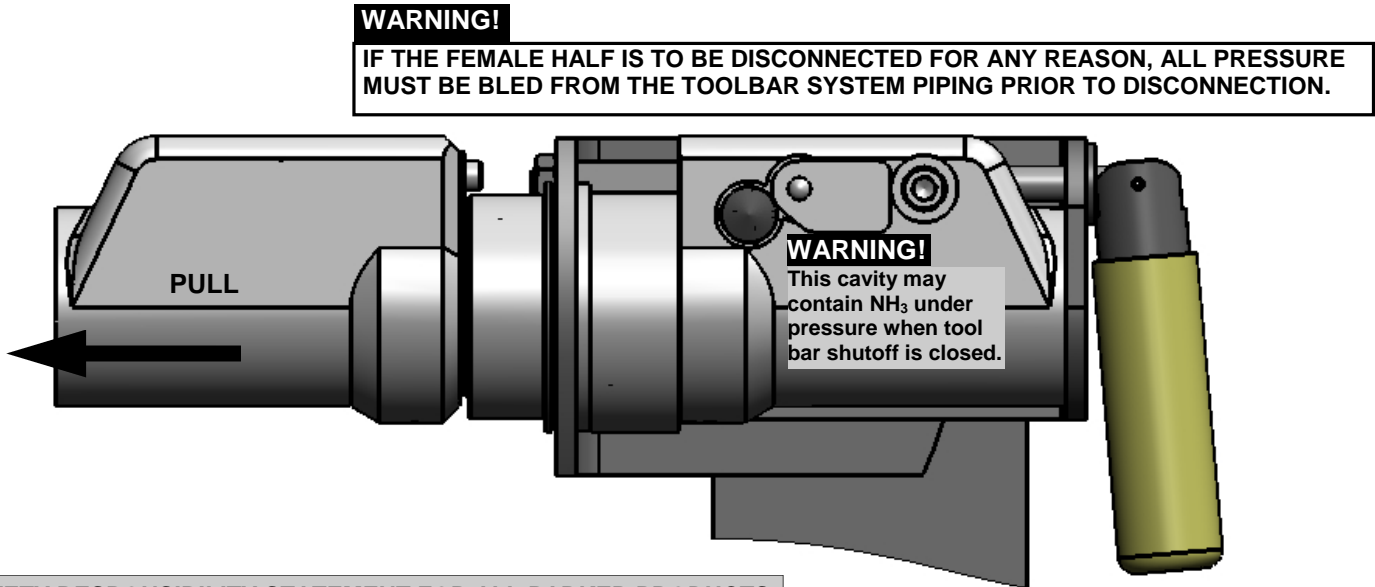

USER SAFETY RESPONSIBILITY STATEMENT FOR ALL PARKER PRODUCTS

FAILURE OR IMPROPER SELECTION OR IMPROPER USE OF THE PRODUCTS DESCRIBED HEREIN OR RELATED ITEMS CAN CAUSE DEATH, PERSONAL INJURY AND PROPERTY DAMAGE.

- This document and other information from Parker-Hannifin Corporation, its subsidiaries and authorized distributors provide product or system options for further investigation by users having technical expertise.
- The user, through its own analysis and testing, is solely responsible for making the final selection of the system and components and assuring that all performance, endurance, maintenance, safety and warning requirements of the application are met. The user must analyze all aspects of the application, follow applicable industry standards, and follow the information concerning the product in the current product catalog and in any other materials provided from Parker or its subsidiaries or authorized distributors.

To the extent that Parker or its subsidiaries or authorized distributors provide component or system options based upon data or specifications provided by the user, the user is responsible for determining that such data and specifications are suitable and sufficient for all applications and reasonably foreseeable uses of the components or systems.

*While this information is presented in good faith and believed to be accurate, Individuals using this literature must exercise their independent judgment in evaluating product selection and determining product appropriateness for their particular purpose, system requirements and certifications. The manufacturer reserves the right to change product designs and specifications without notice.*

## SERVICE KITS

If O-rings become worn or damaged, Service Kits are available through your local distributor.

**Service Kit Number FM150-0022 & FM150-0024 (See FIGURE below for item numbers.)**

ITEM	QTY.	PART NO.	DESCRIPTION
1	1	FM125-5012	BALL CARRIER INSTALLATION TOOL (not shown) Included with FM150-0022 ONLY.
2	2	P5-197-R0	O-RING (2-220)
3	1	P5-169-R0	O-RING (2-128)
4	1	110-2003	O-RING (2-127)
5	1	P5-304-R0	QUAD O-RING (QR-132)
6	1	P5-086-R0	O-RING (2-030)

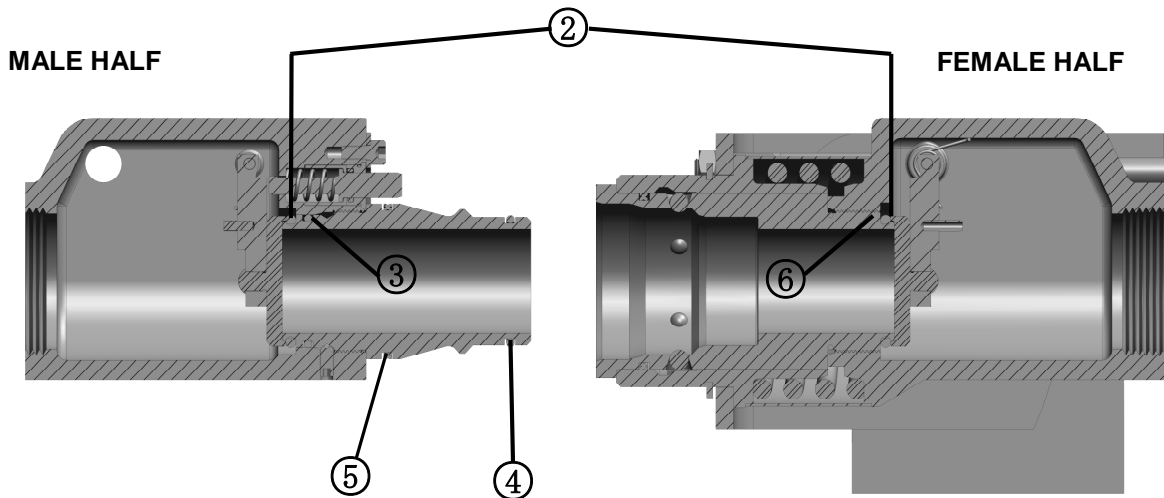
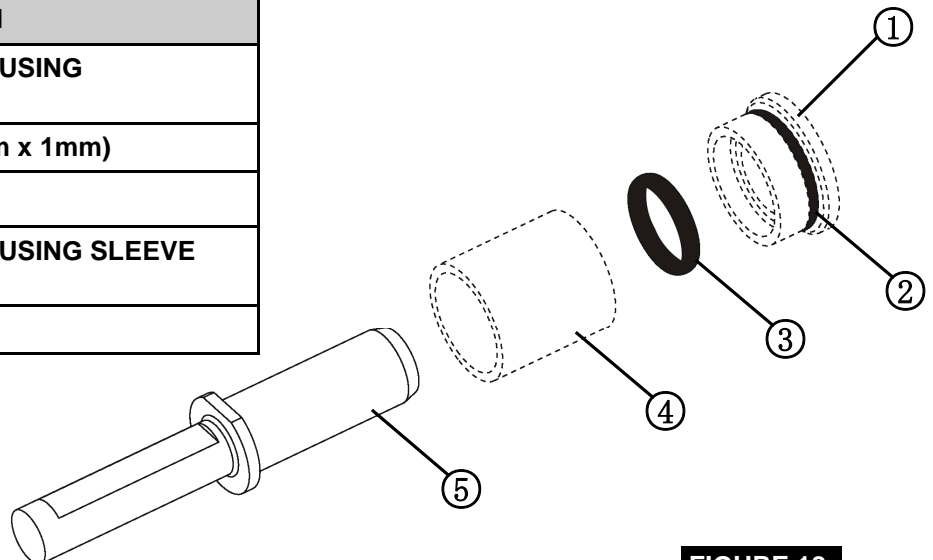

**FIGURE 17**

If the Plunger or Plunger O-Rings become damaged, a Service Kit is available through your local distributor.

**Service Kit Number FM125-0023 (See FIGURE 18 for item numbers.)**

ITEM	QTY.	PART NO.	DESCRIPTION
1	1	FM125-5013	PLUNGER HOUSING (not included)
2	1	P5-133-R0	O-RING (11mm x 1mm)
3	1	P5-015-R4	O-RING 2-011
4	1	FM125-5014	PLUNGER HOUSING SLEEVE (not included)
5	1	FM125-5009	PLUNGER



**FIGURE 18**

*While this information is presented in good faith and believed to be accurate, Individuals using this literature must exercise their independent judgment in evaluating product selection and determining product appropriateness for their particular purpose, system requirements and certifications. The manufacturer reserves the right to change product designs and specifications without notice.*