

Appendix E—Outline Dimensions

Models 91–691 and F91–F691 Bare with Flywheel

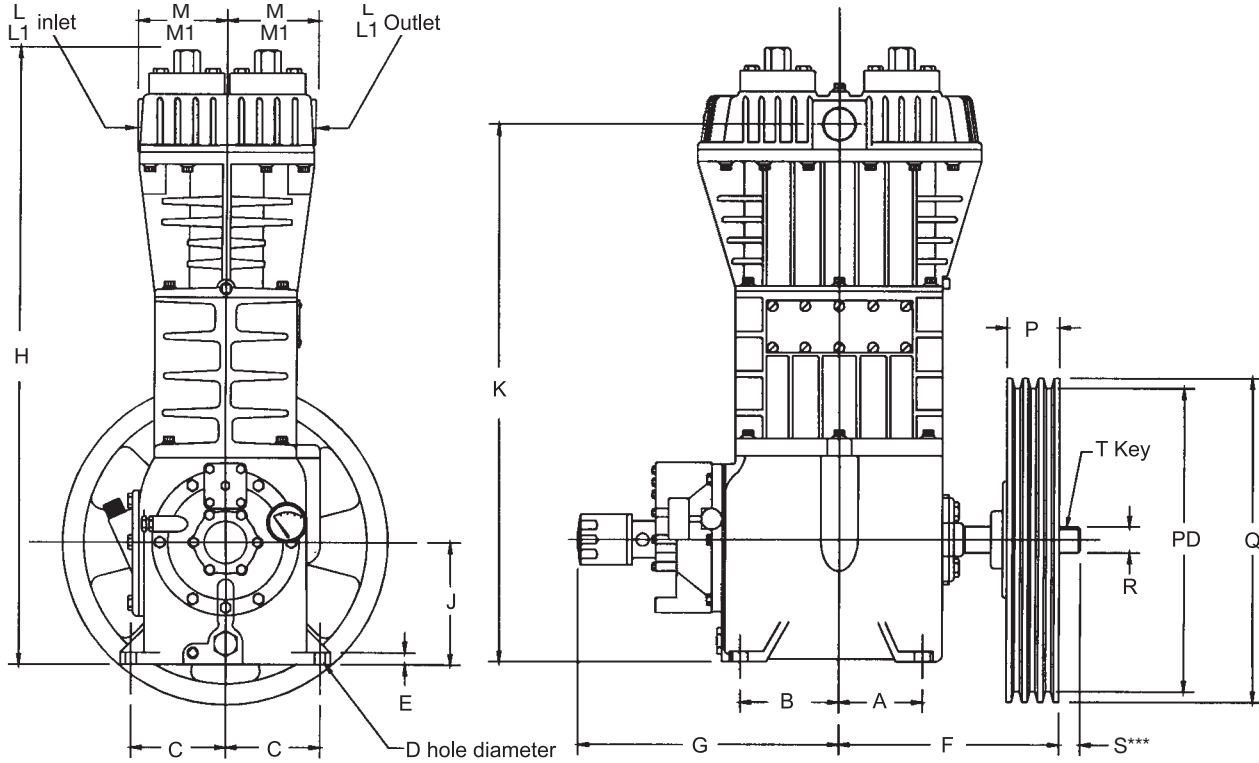

Outline Dimensions—Inches (Centimeters)

Model	A	B	C	D	E	F	G	H	J	K
91, F91	1-13/16 (4.6)	2-3/8 (6.0)	3-11/16 (9.4)	13/32 (1.03)	5/8 (1.59)	6-1/4 (15.9)	3-7/8 (9.8)	25-5/16 (64.3)	5 (12.7)	22-11/16 (57.6)
291, F291	3-3/8 (8.6)	4-1/8 (10.5)	3-11/16 (9.4)	13/32 (1.11)	5/8 (1.59)	9-13/16 (24.9)	12 (30.4)	25-13/16 (65.2)	5-3/8 (13.7)	23-3/8 (59.4)
491, F491	4-1/8 (10.5)	5 (12.7)	4-11/16 (11.9)	1/2 (1.27)	11/16 (1.75)	10-11/16 (27.2)	13 (33.1)	29-11/16 (75.4)	5-7/8 (14.9)	26-3/16 (66.5)
691, F691	4-3/4 (12.1)	5 (14.0)	5-3/8 (13.7)	9/16 (1.5)	1 (2.5)	14 (35.6)	14-3/8 (35.6)	39-1/8 (99.4)	8-1/4 (21.0)	35-1/8 (89.2)

Model	L*	L1**	M*	M1**	P	Q	R	S***	T	"PD" Flywheel Pitch Diameter			
										A-belt Groove	B-belt Groove	B-belt Groove	B-belt Groove
91, F91	3/4 NPT	3/4-300 lb ANSI	2-3/8 (6.0)	4-1/4 (10.8)	3 (7.6)	14 (35.6)	1-1/8 (2.8)	1-1/4 (3.2)	1/4 (0.63)	13.2 (33.5)	2 (34.5)	13.6 (34.5)	2
291, F291	3/4 NPT	3/4-300 lb ANSI	2-11/16 (6.8)	4-1/4 (10.8)	3 (7.6)	16 (40.6) 14 ¹ (35.6)	1-1/4 (3.2)	1-1/4 (3.2)	1/4 (0.63)	15.2 (38.6) 13.21 (33.5)	3 (39.6) 2 (34.5)	15.6 (39.6) 13.6 ¹ (34.5)	3 (39.6) 2 (34.5)
491, F491	1-1/4 NPT	1-1/4-300 lb ANSI	3-7/8 (9.9)	5-5/8 (14.3)	3 (7.6)	16 (40.6) 14 ¹ (35.6)	1-3/8 (3.5)	1-1/4 (3.2)	5/16 (0.79)	15.2 (38.6) 13.21 (33.5)	3 (39.6) 2 (34.5)	15.6 (39.6) 13.6 ¹ (34.5)	3 (39.6) 2 (34.5)
691, F691	2 ² NPT	2-300 lb ANSI	6-3/8 (16.1)	6-15/16 (17.6)	3-13/16 (9.7)	19-1/2 (49.5)	2-1/8 (5.4)	—	1/2 (1.27)	—	—	19-1/8 (48.5)	4

¹ Optional flywheel

² Optional flanges: 1-1/4", 1-1/2" NPT, 1-1/4", 1-1/2" or 2" Weld

* 91, 291, 491, 691 only

** F91, F291, F491, F691 only

*** With extended crankshaft option only