

MANUFACTURED BY PARKER - PGI DIVISION

November 2015

Form FVC104

Installation, Operation & Maintenance Instructions for AL134, AL214 ACME Swivel Lock

IMPORTANT: KEEP THIS DOCUMENT WITH THE PRODUCT UNTIL IT REACHES THE END USER.

WARNING!

1. Contact with or inhalation of Liquid Anhydrous Ammonia (NH₃) can cause **SERIOUS INJURY OR DEATH**.
2. Before installation or removal of ACME Swivel Lock, the system must be purged of all product.
3. Personal Protective Equipment (PPE), safety gloves, goggles and clothing should be worn.
4. For proper handling and storage of NH₃, refer to ANSI Standard K61.1.
5. For LP-Gas Service, follow **NFPA / ANSI 58 Standard** for the Storage and Handling of Liquefied Petroleum Gases, plus any and all Local and State Safety Regulations.
6. An abundant supply of fresh water should be available to provide immediate first aid treatment for exposure to NH₃.
7. To ensure long term safe operation, the manufacturer recommends that under normal service conditions this product should be inspected at least once every year and be repaired or replaced as required.

USE PROPER SAFETY EQUIPMENT AT ALL TIMES. PURGE THE SYSTEM COMPLETELY OF ALL PRODUCT.

TOOLS REQUIRED

Safety Equipment (i.e. gloves, goggles, and clothing), Philips Screw Driver #2, Adjustable Wrench.

NOTE:

This manual illustrates typical installation of ACME Lock (AL134 & AL214) onto swivel adapter (A1131F & A1132F)

PART NO.	DESCRIPTION	UNIT
AL134	1-3/4" ACME SWIVEL LOCK	1 SET
AL214	2-1/4" ACME SWIVEL LOCK	1 SET

While this information is presented in good faith and believed to be accurate, Individuals using this literature must exercise their independent judgment in evaluating product selection and determining product appropriateness for their particular purpose, system requirements and certifications. The manufacturer reserves the right to change product designs and specifications without notice.

Maximum Pressure : 400 psi
Chemical Compatibility : NH3 & LP

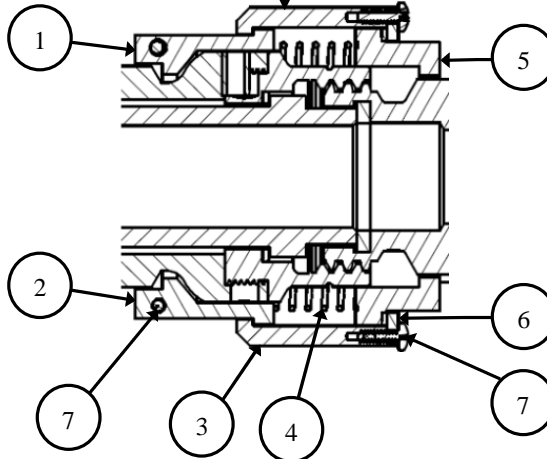
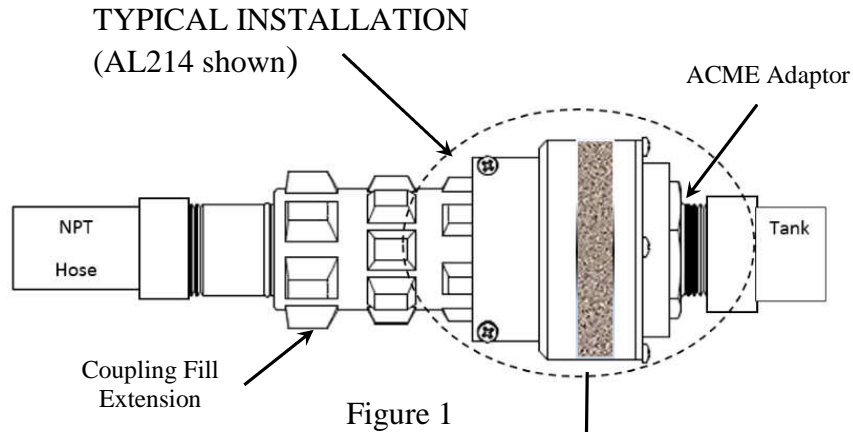

ITEM	DESCRIPTION	AL134 1-3/4" ACME	AL214 2-1/4" ACME	QTY
1	UNION MOUNT 1 ACME	134-5005	214-5005	1
2	UNION MOUNT 2 ACME	134-5004	214-5004	1
3	OUTER SLEEVE	134-5002	214-5002	1
4	COMPRESSION SPRING	P1-272-90	P1-273-90	1
5	LOCK RING	134-5001	214-5001	1
6	GEAR PLATE	134-5003	214-5003	1
7	THREAD LOCKING SCREW	P6-276-A0	P6-276-A0	6

While this information is presented in good faith and believed to be accurate, Individuals using this literature must exercise their independent judgment in evaluating product selection and determining product appropriateness for their particular purpose, system requirements and certifications. The manufacturer reserves the right to change product designs and specifications without notice.

Installation of New ACME Swivel Lock

Step 1: Install items #1 and 2 on Coupling Fill Extension as shown on Figure 2, be sure to line up emboss on slot provided and should sit on the grooves.

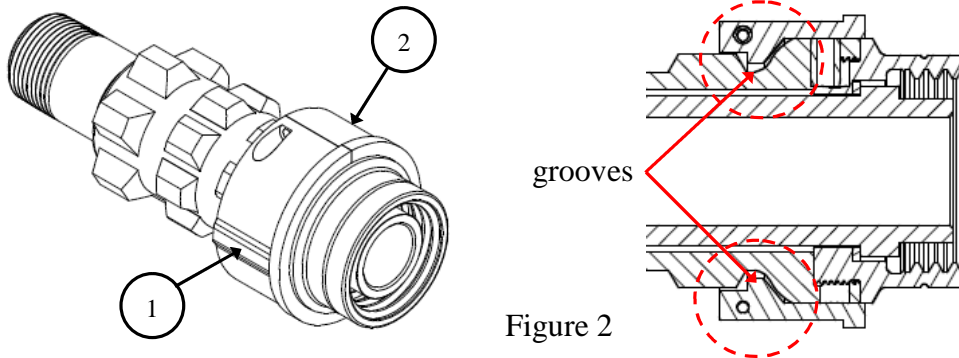

Step 2: Slide Item #3 over Items # 1 and 2 , be sure to line up with slot provided as shown on Figure 3.

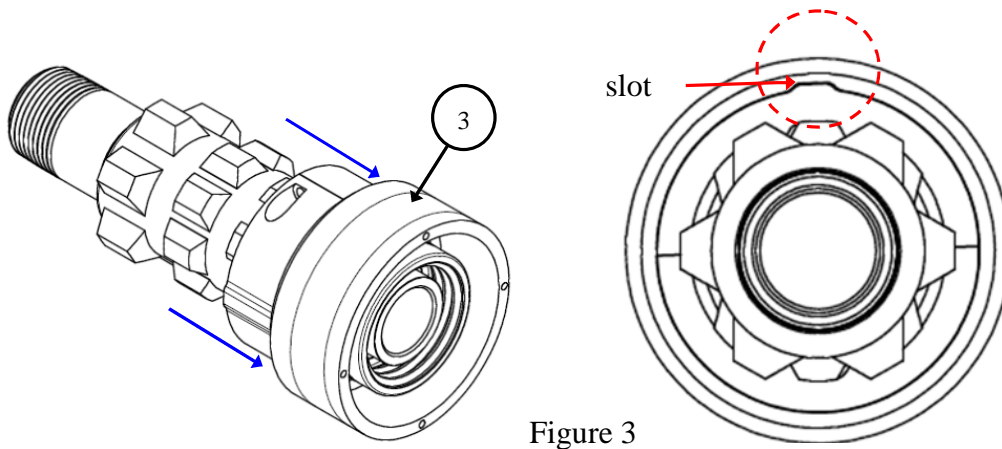

Step 3: Secure with Thread Locking Screw (2) as shown on Figure 4.

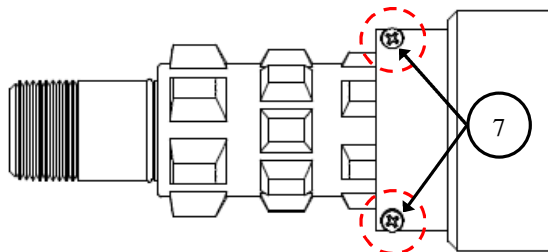

While this information is presented in good faith and believed to be accurate, Individuals using this literature must exercise their independent judgment in evaluating product selection and determining product appropriateness for their particular purpose, system requirements and certifications. The manufacturer reserves the right to change product designs and specifications without notice.

Installation of New ACME Swivel Lock ... continuation

Step 4: Install Spring (Item #4) and secure with Lock Ring (Item #5) as shown on Figure 5.

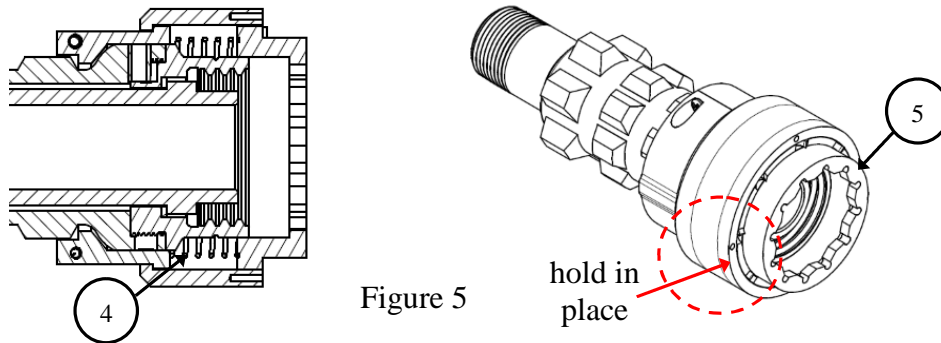

Step 5: While holding Lock Ring in place, Install Gear Plate (Item #6) (Gears facing towards lock ring) onto outer sleeve (Item #3) and secure with Thread Locking Screws (4) in criss-cross pattern and hand tight (30-50 in-lbs ref) shown on Figure 6.

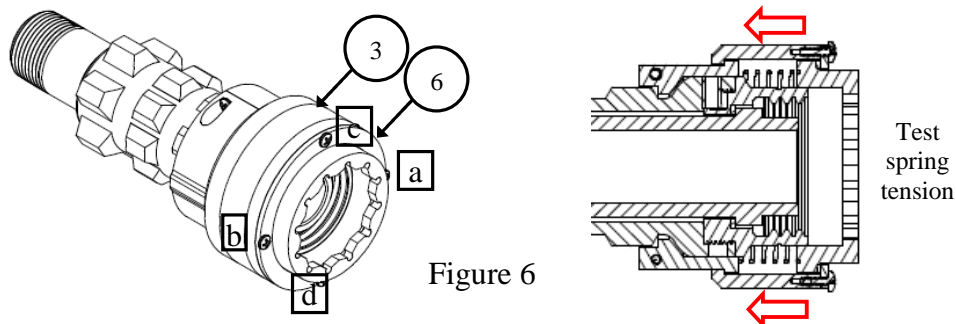

Step 6: Test spring tension by pushing the lock ring a few times making sure it spring back to original position

Step 7: ACME Swivel Lock is ready to use after successful testing otherwise review installation steps.

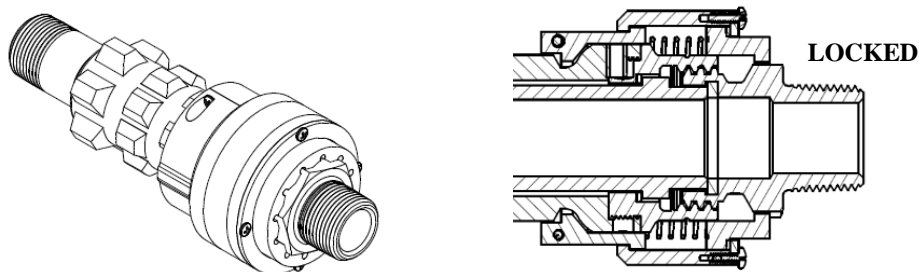

Figure 7

This ACME Swivel Lock will latch on ACME Adaptor's hex and secure, so that it doesn't turn in anticlockwise direction.

Note: Automatically lines up with the hex on the ACME Adaptor and slides over the hex and prevents it from backing up or vibrating loose.

While this information is presented in good faith and believed to be accurate, Individuals using this literature must exercise their independent judgment in evaluating product selection and determining product appropriateness for their particular purpose, system requirements and certifications. The manufacturer reserves the right to change product designs and specifications without notice.

Releasing the ACME Swivel lock

Note: Safety Equipment (i.e. gloves, goggles, and clothing) must be worn before continuing with the next step.

Step 1: Pull back the Outer Sleeve Item#3 which is spring loaded to release from the ACME Adapter hex.

Step 2: Rotate the swivel Adapter counter clockwise holding the outer sleeve back.

Step 3: This will disengage the ACME lock from the hex adapter.

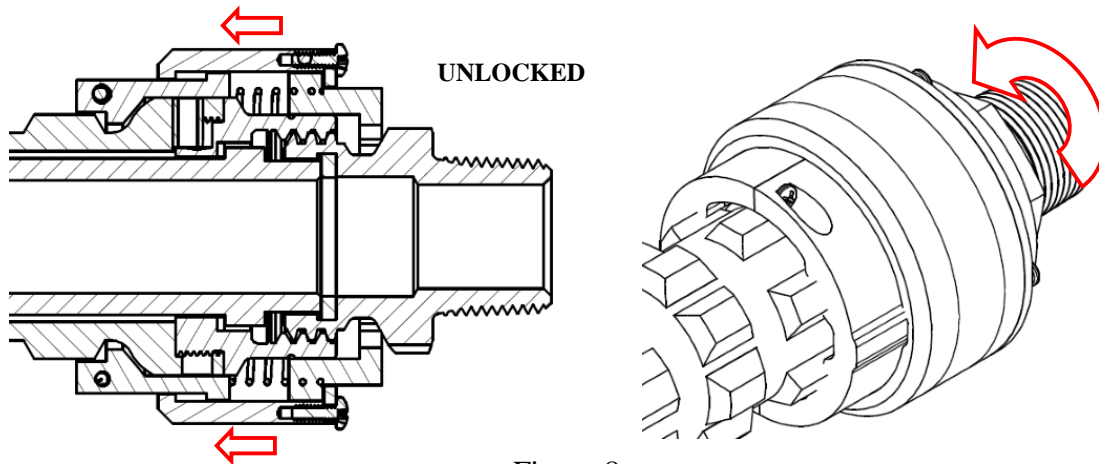

Figure 8

USER SAFETY RESPONSIBILITY STATEMENT FOR ALL PARKER PRODUCTS

FAILURE OR IMPROPER SELECTION OR IMPROPER USE OF THE PRODUCTS DESCRIBED HEREIN OR RELATED ITEMS CAN CAUSE DEATH, PERSONAL INJURY AND PROPERTY DAMAGE.

- This document and other information from Parker-Hannifin Corporation, its subsidiaries and authorized distributors provide product or system options for further investigation by users having technical expertise.
- The user, through its own analysis and testing, is solely responsible for making the final selection of the system and components and assuring that all performance, endurance, maintenance, safety and warning requirements of the application are met. The user must analyze all aspects of the application, follow applicable industry standards, and follow the information concerning the product in the current product catalog and in any other materials provided from Parker or its subsidiaries or authorized distributors.

To the extent that Parker or its subsidiaries or authorized distributors provide component or system options based upon data or specifications provided by the user, the user is responsible for determining that such data and specifications are suitable and sufficient for all applications and reasonably foreseeable uses of the components or systems.

While this information is presented in good faith and believed to be accurate, Individuals using this literature must exercise their independent judgment in evaluating product selection and determining product appropriateness for their particular purpose, system requirements and certifications. The manufacturer reserves the right to change product designs and specifications without notice.