

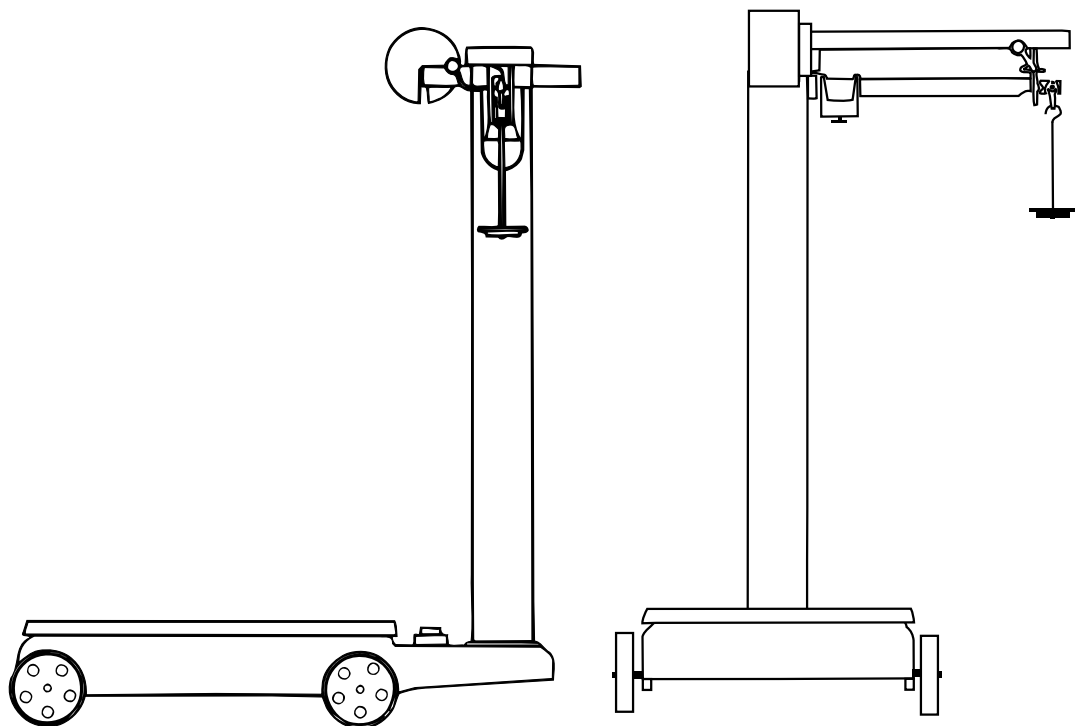

Portable Platform Scale

Models: 1124 & 1124-1



Amendment Record

Portable Platform Scale 1124 & 1124-1 50595

Manufactured by Fairbanks Scales Inc.
821 Locust
Kansas City, Missouri 64106

Created	6/88	
Issue #1	6/88	
Issue #2	5/01	Updated assembly instructions and part numbers.
Issue #3	11/09	Revised assembly instructions.
Revision 4	08/10	Added information for item 46 in the parts lists.
Revision 5	03/11	Revised parts lists.
Revision 6	03/13	Revised parts lists.
Revision 7	09/15	Changed part #96853 to #95853

Table of Contents

Section 1: Introduction	4
Section 2: Description	5
Section 3: Installation	
A. Unpacking	6
B. Assembly	6
1. Wheel & Pillar Assembly	6
2. Cap & Beam Assembly	7
3. Operation	10
Section 4: Parts & Diagrams	
1124 (lbs)	12
1124-1 (kgs)	14

Disclaimer

Every effort has been made to provide complete and accurate information in this manual. However, although this manual may include a specifically identified warranty notice for the product, Fairbanks Scales makes no representations or warranties with respect to the contents of this manual, and reserves the right to make changes to this manual without notice when and as improvements are made.

Section 1: Introduction

This manual provides information on installation, adjustment, and parts list for the model 1124 and 1124-1 portable platform scales. Please read carefully while assembling the scale. The scale is factory calibrated and supplied ready to be assembled and placed into service. For commercial applications, scale must be installed by a certified scale technician.

Note : *Adjustments to the weighing accuracy should only be made by trained scale personnel. No modifications are to be made to this equipment.*

Upon receipt, ensure that no shipping damage has occurred. Damage to the shipping carton must be noted by the receiving party, and made known to the shipper. Claims for shipping damage are made by the receiving party to the shipper.

It is the customer's/owner's responsibility to maintain the scale in good operating condition and to protect the scale from accidental damage.

Section 2: Description

The 1124 and 1124-1 portable platform scales are constructed with cast iron bases and cast iron lever systems. The indicating devices are a mechanical beam (in lbs. or kgs.) or, with accessories, an electronic instrument for displaying the weight

Note : *The 1124's shipping weight is approximately 185 lbs. Please use caution to prevent injury, and or damage to the product.*



Models and accessories :

Model#	Ref #	Description	Shpg Wt
55652	1124	18" x 24" Port platform, 1000 lb cap, lbs. beam indicator	185 lbs
55653	1124-1	18" x 24" Port platform, 500 kg cap, kg. beam indicator	185 lbs

Section 3: Installation

A. Unpacking:

Check that all parts are included using the packing list.
Check for component damage that may have occurred during shipping.

B. Assembly:



Caution: *The scale base assembly, as shipped, weighs 105 lbs., use caution when lifting.*

1. Wheel and Pillar Assembly

Note: *The descriptions below refer to "Item No" to describe parts. Use the parts list and Item # in the list to identify those parts.*

- a. Set the scale base assembly (#4) upright on the floor.
- b. Starting with an axle (#19), insert a cotter pin (#17) in 1 end, then place 1 washer (#18) & 1 wheel (#16) over the open end.
- c. Insert the axle's other end through BOTH holes in the base.
- d. Place a wheel (#16), then 1 washer over the other end and insert a cotter pin.
- e. Repeat steps 2-4 for the 2nd axle.
- f. 'Center' the axles in the base, then insert the locking screws (#15) into the tapped holes in the bottom of the base (directly under the axle holes).
- g. Tighten the locking screws, then secure the lock nuts (#14).

- h. Screw the two (2) pillar rods (#1) into the base in the two (2) tapped holes provided.
- i. Place the pillar (#2) over the pillar rods with the cutouts facing to the left and right of the platform
- j. Insert the beam load rod (#35) down through the pillar, with the bent hook on top, loose swivel hook on the bottom.

2. Cap and Beam Assembly for 1124 and 1124-1 Models
(Beam Installations):

- a. Place the beam support (#39) over the pillar rods with the "hook" facing to the right (when facing the scale platform).
- b. Place the beam cap (#45) over the pillar rods, with the beam cap extending to the right.
- c. Place washers then 'acorn' nuts (#44) over the pillar rods, hand tighten only.
- d. **Locate the loop assembly that will support the beam assembly from the beam cap. THIS LOOP MUST BE INSTALLED CORRECTLY TO ALLOW THE POISE TO SLIDE TO ZERO.** Orient the open end of the loop assembly to face the end of the beam assembly when installing. Refer to the drawing on page 13.
- e. Fit the loop over the pivot on the butt END of the beam.
- f. Insert the beam into the cutouts in the pillar, then the beam tip through the beam lock (#43) so that the beam's MIDDLE loop (on top) will go OVER the 'hook' on the beam support (thus hanging from the hook).
- g. Put the UPPER end of the beam load rod through the large END loop on the butt of the beam.
- h. From the rear of the scale, locate the BOTTOM end of the

beam load rod (the open part of the 'hook' on the bottom should face the scale base (inward)).

- i. Holding the rod's BOTTOM hook, put it UNDER the pivot on the END of the scale lever by lifting on the long lever end from the bottom.
- j. Fit the beam lock (#43) over the beam tip and align with the 2 holes in the beam cap and use the 2 screws to fasten the beam lock to the beam cap with the handle facing the scale platform.
- k. Hang the counterpoise (#54) from the beam tip loop.
- l. Set the sliding poise to zero and hand tighten the screw.
- m. Check that the beam is straight and does not touch the sides of the trig lock.
- n. Shift the cap if necessary to straighten, then tighten the 'acorn' nuts securely.

Note: *Check that the weighing platform "floats" on the levers' pivots and bearings and does not bind or set to one side. The platform should return to a centered position if moved to any position then released.*

- o. Unlock the beam lock loop to allow the beam to balance.
- p. The beam should move up and down freely coming to rest in the center of the trig lock opening. Balance the beam by adjusting the balance ball at the butt end of the beam, using a screwdriver.
 - Turning the screw CW will RAISE the beam
 - Turning the screw CCW will LOWER the beam.

- q. If the beam will not balance using the balance ball :
- Check that the poise is at "0" and the poise screw is snug.
 - Check that the platform is 'free' and 'floating'.
 - Check that the beam load rod is connected properly on BOTH ends.
 - Check that there is nothing under the platform inhibiting the levers (floor debris).
 - Check that the counterpoise hanger, without any weights, is on the tip loop.
 - Check that the beam is hanging from the middle loop.
 - Check that the beam lock is 'open'
 - Apply a slight pressure to the scale platform and see if the beam tip rises.
 - If "YES" continue on to balance, if "NO", recheck mechanical assembly.

If the scale beam still does not balance perform the following:

- Use a screwdriver to 'center' the balance ball at the butt end of the beam.
- If the beam is "UP", apply small amounts of weight (BBs) to the top of the counterpoise.
- If the beam is "LOW", remove the counterpoise hanger, loosen the hanger rod by turning and holding the bottom nut, and remove a small amount of lead shot.
- Add or remove small amounts of weight until beam balances.
- Secure the counterpoise hanger with "added" or "removed" weight.

3. Operation:

a. Zeroing: Before weighing an object, ensure that the scale is on ZERO with nothing on the platform. To do this, set the sliding poise to "0", release the beam lock, and observe the beam within the beam lock loop. (The beam should move from near the top to near the bottom eventually settling 'balancing' in the center). If not, adjust the zero balance ball using a flat blade screw driver.

- If the beam stays at the top of the beam lock loop, turn the balance ball screw counter-clock-wise.
 - If the beam stays at the bottom of the beam lock loop, turn the balance ball screw clock-wise.
- Adjust the balance ball until the beam will balance at the center of the beam lock loop.

b. Weighing:

- Check that the beam lock is 'ON' (lever flipped to the left)
- Carefully place the object to be weighed in the platform center
- Run the sliding poise to the right end of the beam, and slowly release the beam lock
- If the beam stays at the bottom of the beam lock loop, slowly slide the poise to the left (decreasing) until the beam balances in the center. Read the weight on the beam at the poise's pointer.
- If the beam stays at the top of the beam lock loop, add counter poise weights to the counterpoise until the beam 'bottoms out', then slowly slide the poise to the left (decreasing) until the beam balances in the center. Read the weight on the beam at the poise's pointer, and add the represented weight of all counterpoise weights used.

This page intentionally left blank.

Section 4: Parts

A. 1124 (lbs)

Item No. "NS" = not shown

Item No.	Part No.	Description
1	71622	Pillar rod, long
2	58933	Pillar
3	95847	Platform cover
4	95848	Frame
5	95855	Cotter pin
6	58937	Bearing, platform
7	95856	Screw, Phillips Head
8	95857	Screw Allen
9	95858	Level, bubble
10	95859	Pin, corner loop
11	71623	Loop, corner
12	71624	Bearing, corner loop
13	71625	Cotter pin
10,11,12,13	58938	Corner loop assembly
14	95867	Hex nut
15	95868	Hex head bolt
16	95869	Wheel, 5" diameter
17	71628	Cotter pin
18	71629	Washer, flat
19	95870	Axle
24	95861	Pivot, load & fulcrum
25	72948	Short lever assy
26	58939	Center connection assembly
31	95863	Center pivot, long lever
33	72947	Long lever assy
34	95864	Long lever tip pivot
35	58934	Steelyard rod assembly
39	95839	Beam support
43	95840	Beam lock assembly
44	71592	Acorn nuts (2)
45	95841	Cap assembly
46	71593	Set of hex bolts
49	95843	Beam assembly (lb), includes: (beam, beam insert, beam pivots, loops, poise w/screw, balance ball)
52	95842	Poise assembly
54	58935	Counterpoise assembly
55	58936	1 lb (100 lb) counterpoise weight
56	95853	2 lb (200 lb) counterpoise weight
57	95854	4 lb (400 lb) counterpoise weight
55, 56, 57	71596	1 Set of (lb) weights (1-58936, 2-96853, 1-95854)
61	95865	Platform locking pin
62	95866	Cotter pin, platform locking pin
NS	98545	Replacement brass insert for beam. Unit = lbs Includes insert for each side of the beam.

A. 1124 (lbs)

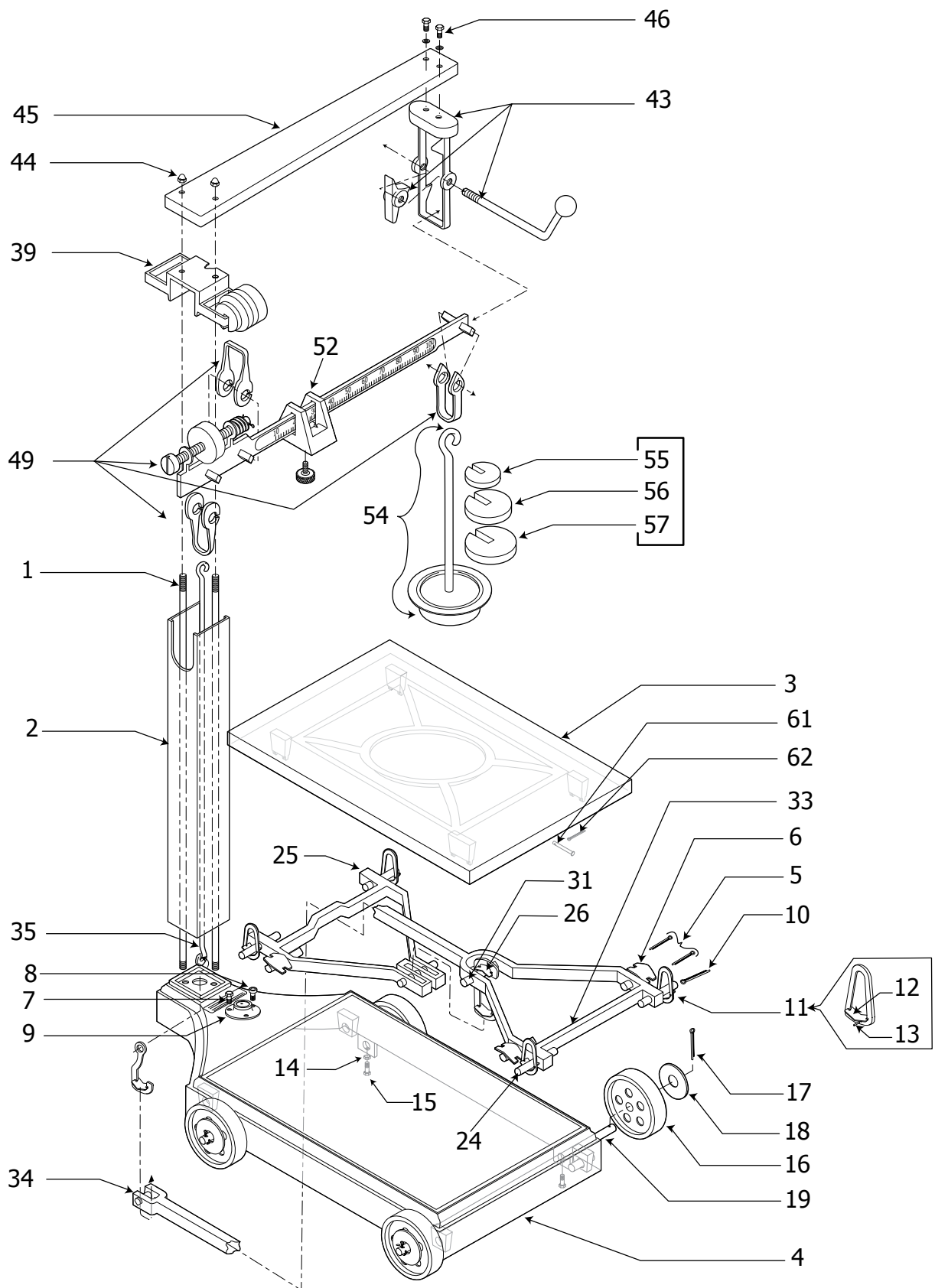

Section 4: Parts - continued

B. 1124-1 (kg)

Item No. "NS" = not shown

Item No.	Part No.	Description
1	71622	Pillar rod, long
2	58933	Pillar
3	95847	Platform cover
4	95848	Frame
5	95855	Cotter pin
6	58937	Bearing, platform
7	95856	Screw, Phillips head
8	95857	Screw Allen
9	95858	Level, bubble
10	95859	Pin, corner loop
11	71623	Loop, corner
12	71624	Bearing, corner loop
13	71625	Cotter pin
10,11,12,13	58938	Corner loop assembly
14	95867	Hex nut
15	95868	Hex head bolt
16	95869	Wheel, 5" diameter
17	71628	Cotter pin
18	71629	Washer, flat
19	95870	Axle
24	95861	Pivot, load & fulcrum
25	72948	Short lever assy
26	58939	Center connection assembly
31	95863	Center pivot, long lever
33	72947	Long lever ssy
34	95864	Long lever tip pivot
35	58934	Steelyard rod assembly
39	95839	Beam support
43	95840	Beam lock assembly
44	71592	Acorn nuts (2)
45	95841	Cap assembly
46	71593	Set of hex bolts
49	72089	Beam assembly (kg), includes: (beam, beam insert, beam pivots, loops, poise w/screw, balance ball)
52	95842	Poise assembly
54	58935	Counterpoise assembly
55	72084	.5kg (50kg) counterpoise weight
56	72085	1kg (100kg) counterpoise weight
57	72086	2kg (200kg) counterpoise weight
55, 56, 57	72087	1 set of kg weights (1-72084, 2-72085, 1-72086)
61	95865	Platform locking pin
62	95866	Cotter pin, platform locking pin
NS	72088	Replacement brass insert for beam. Unit = kg Includes insert for each side of the beam.

B. 1124-1 (kgs)

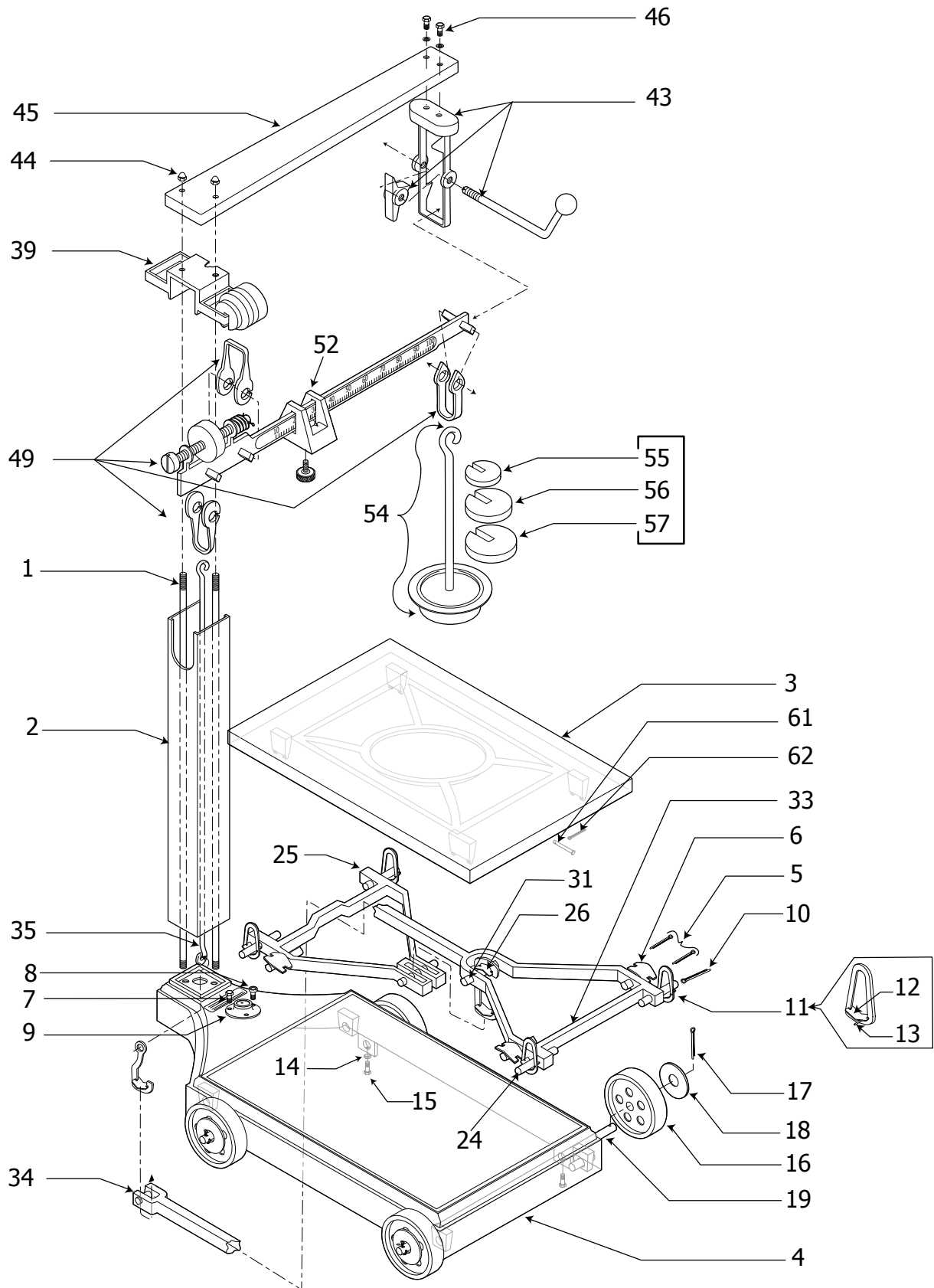

This page intentionally left blank.