

Installation, Operation & Maintenance

Form IOM-SK-1004-R, Rev. 12

Standard Features

- Completely self-contained (GPS, receiver, antenna, and velocity to pulses converter)
- 16 Channel GPS receiver
- Can be used with all equipment that is compatible with radar or pulse type speed sensors
- 0.1 MPH accuracy from 0.5 to 50 MPH
- Surface, bracket, pipe, or magnetic mount
- UV stable, plastic enclosure
- 4 updates per second

SkyTrak is a GPS based velocity sensor that produces true ground speed pulses to equipment designed to interface with radar ground speed and wheel speed sensors. SkyTrak can be quickly transferred from vehicle to vehicle, provides high accuracy, and is easy to install and use. Simply make the connection to your monitor/control equipment, perform the same calibration you would use for other pulse sensors, and you're ready to go.

Physical Specifications

Cable Length	15 feet
Power	4.8 to 16 Volts, 0.1 Amps max.
Backup Battery	CR2032 Lithium Coin
Size	4.50" x 2.43"
Operating Temp.	-40°C to +65°C (-40°F to +149°F)
Storage Temp.	-40°C to +80°C (-40°F to +176°F)
Humidity	100% Condensing

Performance Specifications

Velocity Accuracy	0.1 MPH (without SA)
GPS Update Rate	4 Hz.
Backup Battery Life	>3 years

Acquisition Rate

Cold Start	<45 seconds
Warm Start	<33 seconds

Raven® Connector Features:

- 3-pin AMP, radar compatible
- 58.94 pulses/MPH
- Pin 1, Ground
- Pin 2, +Power
- Pin 3, Signal (Pulses)

Other Available Models:

SK-1004-D
SK-1004-M

Connector Type:

DICKEY-john®
Micro-Trak® Calc-An-Acre®

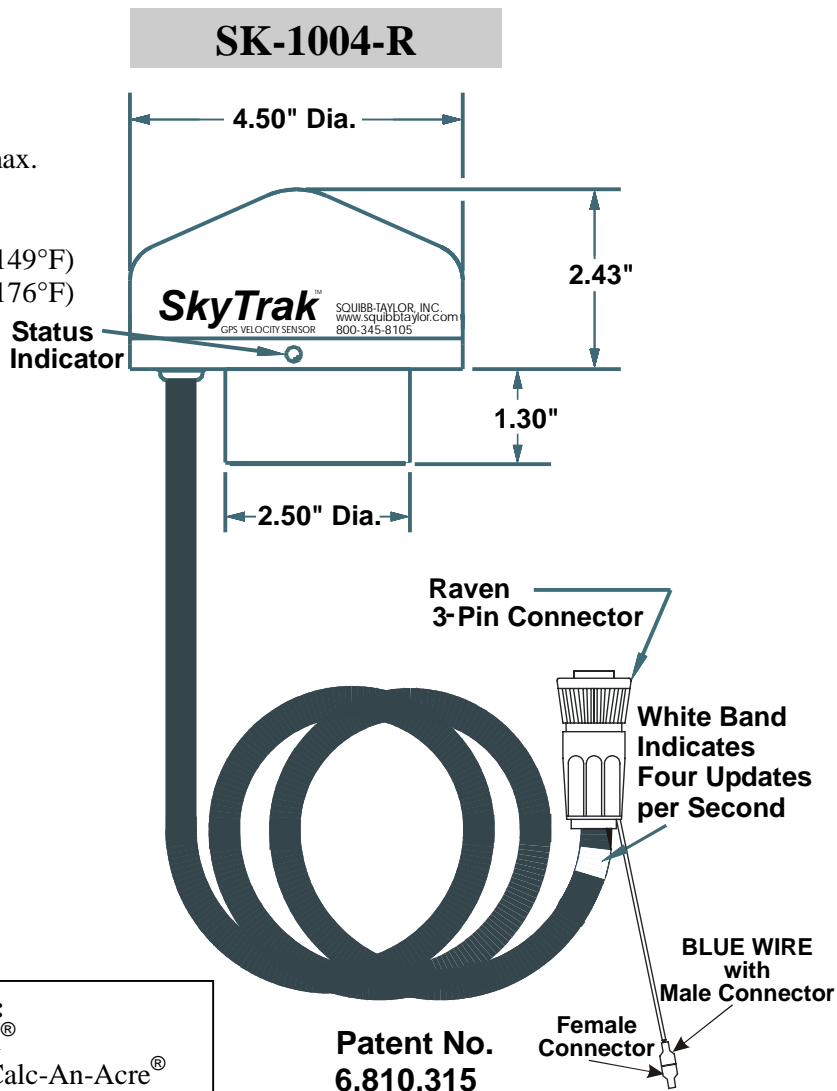

Operation

When power is applied, the SkyTrak status indicator will flash green once and then red while the GPS receiver completes its startup. The GPS receiver has an almanac, which is a table of satellites and their locations in space. Before SkyTrak can provide speed information, the GPS receiver must download this table from each satellite.

The first time the SkyTrak receiver is turned on, it will have no satellite information. This is a cold start and will take less than 45 seconds. A warm start occurs when there is a partial table in the receiver, or the table is being updated, and takes less than 33 seconds. A hot start takes place when power to SkyTrak is off for only a short time. The sensor will be ready in less than 20 seconds. SkyTrak uses a small internal battery to keep the table information when power is removed to minimize startup times, but the longer power is removed, the longer it will take the receiver to acquire current satellite information.

During startup, the status indicator on the front of the SkyTrak unit will be red. After a couple of satellites are available, the indicator will flash one time for each satellite that is being used. When enough satellite information is obtained to calculate ground speed, the indicator will change to green. As long as SkyTrak is using less than four satellites, the indicator will flash the number of satellites in use every 5 seconds (if three satellites are in use, flash – flash – flash, on solid for about five seconds, and then flash again). Solid green indicates more than four satellites are being used and accurate speed pulses are available. Solid red indicates SkyTrak is in the startup process or is unable to locate satellites.

Power Supply

SkyTrak requires 4.8 to 16 volts at about 0.1 amps to operate. Although the Raven controller speed sensor interface connector provides 5 volts and ground to power some radar guns, it does not supply enough power for the SkyTrak sensor. **SkyTrak power must be supplied separately.** The positive lead of the SkyTrak power should be connected to the blue lead at the connector end of the SkyTrak harness. To simplify installation, a 1-pin crimp-on connector is provided. Using the connector will also make it easy to unplug the SkyTrak if it needs to be removed. Ground, or the power minus connection, is provided through the controller's speed sensor interface connector **which must be a proper ground.** Choose a power source that is fused and switches off when the tractor is off.

Mounting Options

Your SkyTrak GPS Velocity Sensor has been shipped in the Magnet Mount configuration. The ¼”-20 x ½” long bolt required for other mounting options has been placed inside the adapter portion of the unit.

Mounting Considerations

- The SkyTrak mounting location should have a clear view of satellites on all sides.
- The SkyTrak unit must be mounted with the dome pointing to the sky.
- Avoid overhead metal structures that can block the satellite signals.
- Avoid mounting in areas with excessive vibration. An antenna that moves or sways may produce ground speed errors. The idea is to have the antenna move only when the vehicle is moving for accurate true ground speed measurement.
- Make sure the cable can be safely routed to the connection point.
- Position the SkyTrak status indicator so that it is easily viewable.
- SkyTrak can be mounted on a flat surface such as the roof of the vehicle cab. If surface mounted, use weatherproof sealant between the roof and the SkyTrak sensor to seal the mounting screw hole and the cable feed hole.
- Be sure to leave access to the two cover screws. These screws will be removed for access to the backup battery.

Magnet Mount

To utilize the Magnet Mount option, simply attach the SkyTrak sensor to a metallic surface, plug in the 4-pin connector and calibrate.

Note: The bottom portion of the magnet has been covered with a plastic film to protect the mounting surface and should not be removed.

If disassembled to utilize another mounting option, your SkyTrak sensor can be returned to the Magnet Mount configuration as shown.

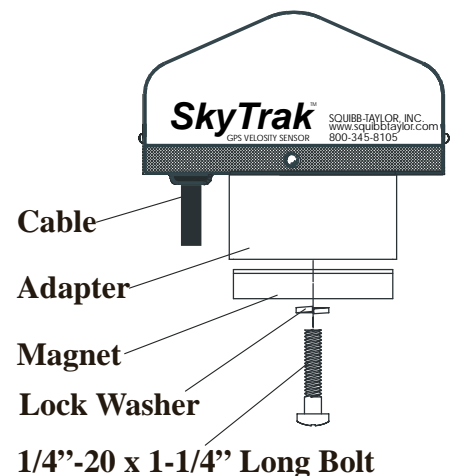

Pipe Mount

To utilize the Pipe Mount option:

- 1) Remove the adapter from the underside of the sensor base.
- 2) Remove the magnet from the adapter. The ½” long bolt required for the Pipe Mount option has been placed inside the adapter.
- 3) Place the lock washer onto the ½” long bolt.
- 4) Insert the bolt through the adapter and screw into the sensor base.
- 5) Screw 1” pipe into adapter. (The 1” pipe is not included.)
- 6) Plug in the connector.
- 7) Calibrate.

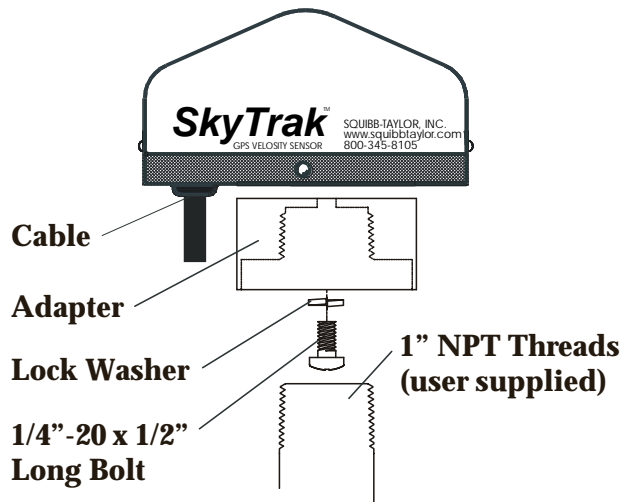

Bracket Mount

To utilize the Bracket Mount option:

- 1) Remove the adapter from the underside of the sensor base.
- 2) Remove the magnet from the adapter. The ½” long bolt required for the Bracket Mount option has been placed inside the adapter.
- 3) Place the lock washer onto the ½” long bolt.
- 4) Insert the bolt through the bracket and screw into the sensor base. (The bracket is not included.)
- 5) Plug in the connector.
- 6) Calibrate.

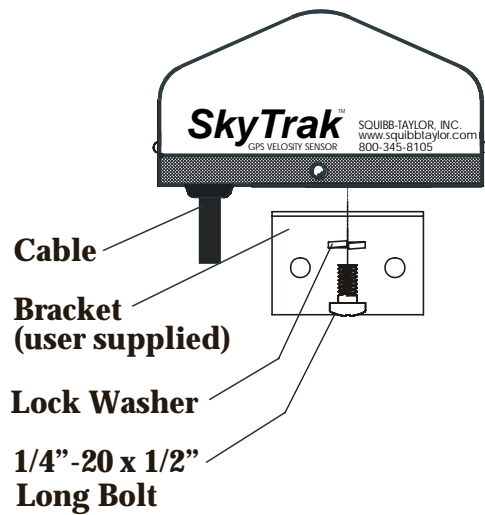

Surface Mount

To utilize the Surface Mount option:

- 1) Remove the adapter from the underside of the sensor base.
- 2) Remove the magnet from the adapter. The ½” long bolt required for the Surface Mount option has been placed inside the adapter.
- 3) Place the lock washer onto the ½” long bolt.
- 4) Insert the cable through the wire feed hole.
- 5) If mounting to the roof of the cab, take care to not defeat the breather hole when sealing the mounting. The breather must be open to atmosphere.
- 6) Insert the bolt through the mounting surface and screw into the sensor base.
- 7) Plug in the connector.
- 8) Calibrate.

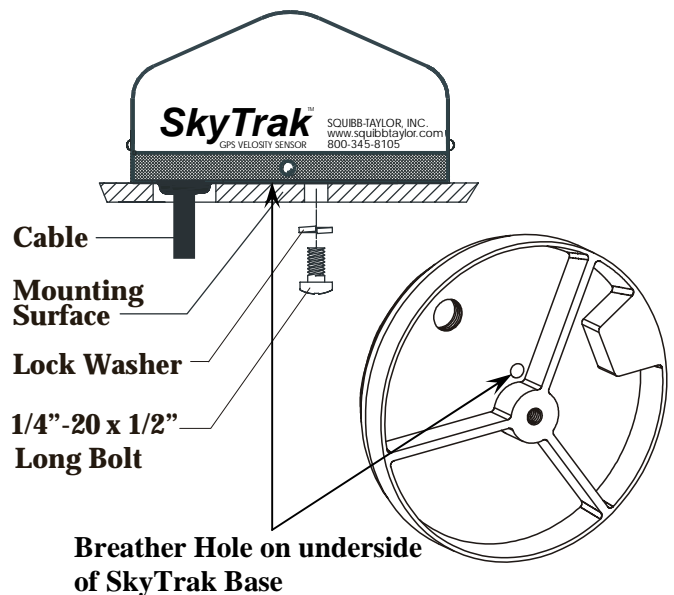

Calibration

After installing SkyTrak, your control equipment will need to be calibrated. Follow the calibration procedure for your controller or monitor as if you were using a radar or wheel speed sensor. Typically, this involves driving an accurately measured distance to determine a speed cal value for your system.

Before running the calibration, allow the SkyTrak to download a full satellite table by turning on SkyTrak where it has a clear view of the sky for about ten minutes. The status indicator should be solid green (using 4 or more satellites) before performing the calibration.

Maintenance

Backup Battery Replacement

The backup battery should be replaced every three years. If the status indicator takes several minutes to switch to green when the unit is powered up after it has been off for only a short time, this is an indication that the battery needs to be replaced.

To replace the backup battery:

- 1) Remove the two cover screws and the cover.



- 2) Locate backup battery and press downward on the center tab until the battery is released.

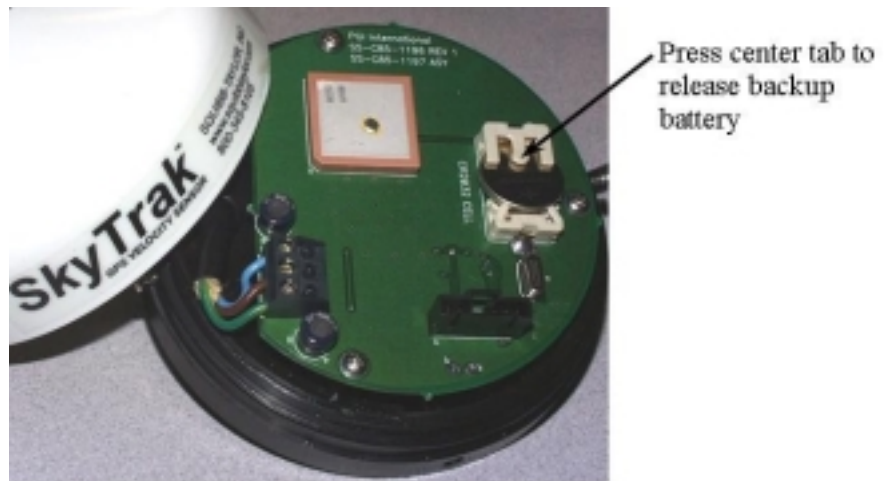

- 3) Remove the old battery and replace with a new CR2032 Lithium Coin battery (positive pole facing upward).
- 4) Re-install the cover and screws.

IMPORTANT!
DO NOT TIGHTEN THE COVER SCREWS ALL THE WAY IN.
LEAVE A SLIGHT GAP BETWEEN THE SCREW HEAD AND THE COVER.

DICKEY-john[®] is a registered trademark of the DICKEY-john Corporation.
Micro-Trak[®] and Calc-An-Acre[®] are registered trademarks of Micro-Trak Systems Incorporated