



# Installation, Operation, Maintenance Disassembly and Assembly Instructions for A1801 Equa-Flo Manifold

February 2003

Form FVC 051 - Rev. 3

**KEEP THIS DOCUMENT WITH THE PRODUCT UNTIL IT REACHES THE END USER.**

## WARNING

Before installation or removal of the Equa-Flo Manifold, the system must be purged completely of all product. Use proper safety equipment at all times. An abundant supply of clean water must be readily available and easily accessible as a means of providing IMMEDIATE First Aid treatment for exposure to ANHYDROUS AMMONIA. To insure long term safe operation, the manufacturer recommends that under normal service conditions this product should be inspected at least once every five (5) years & be repaired or replaced as required.

**CAUTION:** Contact with or inhalation of Liquid Anhydrous Ammonia or its vapors can cause serious injury or death. Dispersment must be in accordance with local regulations. For the proper handling and storage of Anhydrous Ammonia refer to ANSI Standard K61.1.

**TOOLS REQUIRED:** Safety Equipment (i.e. gloves, goggles, and clothing), 7/16" and a 9/16" Open End Wrench and a 3/16" Allen Wrench.

## Installation and Operating Instructions

REFER TO FIGURE 1 FOR THE FOLLOWING STEPS:

### Installation Instructions

**NOTE:** If two or more Equa-Flo manifolds will be used on one tool bar, please refer to form FVC-052 for proper installation using 2-way, 3-way and 4-way splitters. Do not use standard tees or crosses as splitters.

- Step 1: Install the Equa-Flo Manifold at the rear of the tool bar using square U-bolts on any 2-1/2 square structural member. (U-bolts not included). The Manifold should be plumbed as level to the ground as possible. Mount the manifold to the mounting plate with the U-bolts, nuts and lockwashers provided.
- Step 2: Each manifold is equipped with 21 ports. Depending on the number of knives on the tool bar, plug the unused ports as symmetrical as possible to obtain the most even distribution of anhydrous ammonia. All hoses should be the same length within six inches.
- Step 3: Install the inlet hose in a gentle sweeping arc into the 1" NPT Swivel Fitting (18). Do not use a 45 or 90 degree elbow to attach the hose to the manifold.
- Step 4: **NOTE:** We strongly recommend that an inline strainer with a 40 mesh screen and a magnet be installed in the tool bar piping somewhere between the safety disconnect coupling and the meter that is measuring the flow of anhydrous ammonia. Rust or bits of tape may obstruct the precision distribution ports and greatly affect the knife-to-knife NH<sub>3</sub> delivery.

### Operating Instructions

#### Startup Procedure

The Equa-Flo manifold is shipped from the factory with the Flow Adjusting Screw (6) exactly 3 turns open. The Flow Indicator Ring (5) will be half way between the Number 1 and Number 2 calibration marks on the Mounting Plate (8). This will be a good starting point for an application rate of 75 lbs. N per acre. A good starting point for 150 lbs. N per acre would be 4 turns open. These settings have proven to be good settings when the nurse tank pressure is around 60 psi.

An essential element of running with the Equa-Flo manifold is knowing the nurse tank pressure and being able to see the manifold pressure while the unit is in operation. A 4" diameter 200-psi dial gage (21) is furnished with each manifold and should be readable from the cab of the tractor. Unlike conventional or even other higher end manifolds, the Equa-Flo requires adjustment to set it up properly for best performance for a given application rate and tank pressure. This adjustability is exactly how the unit achieves its superior performance.

**CAUTION:** With a high tank pressure it is possible to set the back pressure so high that you will not achieve the application rate that is desired. In this case reduce the back pressure and/or drive at a slower speed to achieve the desired rate.

#### Begin Application of NH<sub>3</sub>

- Step 1: Begin application of one row and observe the manifold back pressure during operation after flow stabilization.
- Step 2: If the operating manifold back pressure is between 60% and 75% of the nurse tank pressure, continue operation. The manifold is properly adjusted.
- Step 3: If the operating manifold back pressure is less than 60% of nurse tank pressure, turn the Flow Adjusting Screw (6) one turn clockwise (in) and run another row to check the back pressure.
- Step 4: If the operating manifold back pressure is greater than 75% of nurse tank pressure, turn the Flow Adjusting Screw (6) one turn counter clockwise (out) and run another row to check the back pressure.

It is not necessary to try and adjust to exactly 75% since testing has shown good performance is obtained anywhere in the 60 to 75% range. If a full turn of correction is too much in a given situation, then some lesser adjustment may be done to achieve the desired back pressure operating range.

## Removal of Equa-Flo Manifold for Repair or Replacement

REFER TO FIGURE 1 FOR THE FOLLOWING STEPS:

- Step 1: Safety Equipment (i.e. goggles, gloves and clothing) must be worn before continuing with the next step.
  - Step 2: Before removing the Equa-Flo Manifold, make sure all pressure is bled from the system.
- NOTE: See Warning at top of first page.

## Disassembly Procedure for Replacement of O-Rings (13), (14) and (12)

REFER TO FIGURE 1 FOR THE FOLLOWING STEPS:

- NOTE: Remove the complete Equa-Flo Assembly including Mounting Plate (8) from the tool bar.
- Before proceeding to Step 1, take note of the number location of the Flow Indicator Ring (5) on Mounting Plate (8) so it can be returned to the same location during the reassembly process.
- Step 1: Remove the Adjusting Screw Stop (7).
  - Step 2: Remove the Flow Adjusting Screw (6) by rotating counter clockwise until the threads are disengaged.
  - Step 3: Remove Nyloc Hex Nut (19) and Washer (20), and then remove Nylon Piston (15).
  - Step 4: Remove O-Rings (13) and (14).
  - Step 5: Remove 6 – ¼ -20 Hex. Head Bolts and 6 – ¼” External Tooth Lock Washers from Distributor Piston Body (2).
  - Step 6: Separate Distributor Piston Body (2) from Distributor Main Body (1) and remove O-Ring (12).

CAUTION: The Distributor Center Core (16) is permanently installed inside the Distributor Main Body (1). Do not attempt to separate from the Main Body. Using compressed air or a clean lint free rag, remove any debris or particles from the bore of the Center Core (16). Do not use a screwdriver or any metal object inside the bore to remove debris, as the surface finish could be damaged, causing Piston (15) to leak.

## Reassembly Procedure

REFER TO FIGURE 1 FOR THE FOLLOWING STEPS:

- Step 1: Install O-Ring (12) into the groove on the Distributor Main Body (1). Lubricate O-Ring with a good quality grease that is compatible with anhydrous ammonia.
  - Step 2: Install the Distributor Main Body (1) into the counterbore of Distributor Piston Body (2).
  - Step 3: Install the 6 – ¼-20 Hex. Head Bolts (11) and 6 – ¼” External Tooth Lock Washers (23) through Distributor Piston Body (2) and cross tighten to a torque of 25 ft.-lbs. into the Distributor Main Body (1).
  - Step 4: Install O-Rings (13) and (14) onto Flow Adjusting Screw (6). Lubricate O-Rings with a good quality grease that is compatible with anhydrous ammonia.
  - Step 5: Install Nylon Piston (15) over the small end of Flow Adjusting Screw (6).
  - Step 6: Install Washer (20) into recess in Nylon Piston (15) and Nyloc Hex Nut (19). Tighten Nyloc Hex Nut (19) against Washer (20) until Nylon Piston (15) will not rotate, and then back off Nyloc Hex Nut (19) ¼ turn to allow Piston (15) to rotate freely.
  - Step 7: Install the Flow Adjusting Screw Assembly (6) by engaging the threads into the center of the Distributor Piston Body (2). Rotate the Flow Adjusting Screw (6) CW until the Flow Indicator Ring (5) reaches the number location position on the Mounting Plate (8) before being disassembled.
  - Step 8: Install the Adjusting Screw Stop (7) into the threaded hole of Mounting Plate (8), and tighten with a 3/16 Allen Wrench.
- The Equa-Flo Manifold may now be returned to service.

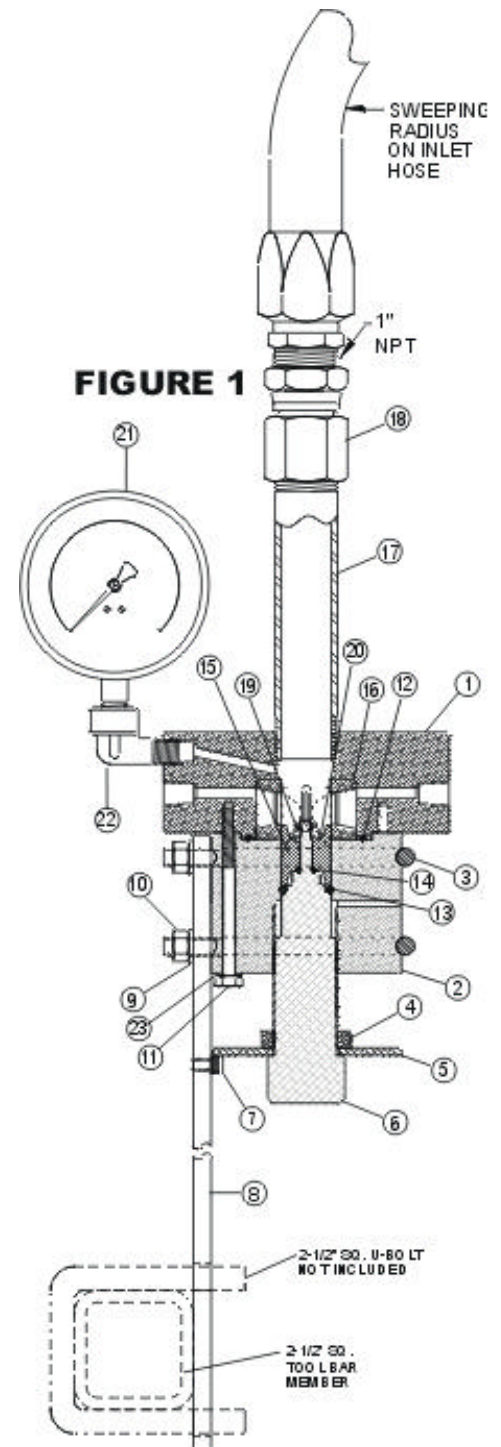

\* INCLUDED INSERIAL KIT #1801-002

NO.	QTY	DESCRIPTION
23	6	1/4" EXTERNAL TOOTH LOCK WASHER
22	1	1/4" MNPT x 1/2" FNPT CS STREET ELL
21	1	1/4" DIA. DIAL 0-200 PSI AMMONIA GAGE
*	1	1/4" WASHER
*	1	1/4"-20 NYLOC HEX NUT
18	1	1" FNPT x 1" FNPT SWIVEL FITTING
17	1	INLET NIPPLE
16	1	DISTRIBUTOR CENTER CORE
15	1	PISTON
*	1	O-RING
*	1	O-RING
*	1	O-RING
11	6	1/4"-20 UNC HEX HEAD BOLT
10	2	3/16" - 16 HEX NUT
9	2	3/16" LOCK WASHER
8	1	MOUNTING PLATE
7	1	ADJUSTING SCREW STOP
6	1	FLOW ADJUSTING SCREW
5	1	FLOW INDICATOR RING
4	1	INDICATOR RING JAM NUT
3	2	U-BOLT
2	1	DISTRIBUTOR PISTON BODY
1	1	DISTRIBUTOR MAIN BODY