



Installation, Operation & Maintenance Disassembly and Assembly Instructions for Emergency Shut Off Valves

June 2000

Form FVC 019

KEEP THIS DOCUMENT WITH THE PRODUCT UNTIL IT REACHES THE END USER.

WARNING

Before installation or removal of any ESV globe or angle valve, the system must be purged completely of all product. Use proper safety equipment at all times. For the use of ANHYDROUS AMMONIA an abundant supply of clean water must be readily available and easily accessible as a means of providing IMMEDIATE First Aid treatment for exposure to ammonia. Installation of valves for LP-GAS in most states must comply with NFPA 58 standards. Therefore, only trained personnel should install and service this equipment. To insure long term safe operation, the manufacturer recommends that under normal service conditions this product should be inspected at least once every five (5) years and be repaired or replaced as required.

CAUTION: Contact with or inhalation of Liquid Anhydrous Ammonia or L-P Gas or their vapors can cause serious injury or death. Dispersment must be in accordance with local regulations.
For the proper handling and storage of Anhydrous Ammonia refer to ANSI Standard K61.1.
For the proper handling and storage of Liquefied Petroleum Gas refer to NFPA Pamphlet 58.

TOOLS REQUIRED: Safety Equipment (i.e. gloves, goggles, clothing), 1/4 Drift Pin, 18" Pipe Wrench, 3/4 Open End Wrench, Screw Driver, Hammer, Channel Lock Pliers, and Stem Seal Assembly Tool (Included in Seal Kit).

Removal of Valve for Repair or Replacement

REFER TO FIGURE 1 FOR THE FOLLOWING STEPS:

Step 1: Safety equipment (i.e. gloves, goggles, clothing) must be worn before continuing with the next step.

Step 2: Before removing valve, make sure system is purged completely of all product.

CAUTION: Place valve in closed position before removing.

Disassembly Procedure For Repair

REFER TO FIGURE 1 FOR THE FOLLOWING STEPS DEPENDING ON THE TYPE OF REPAIR REQUIRED:

- Step 1: With valve closed and secured in a bench vise, remove the four Hex Nuts (29).
Note: A downward pressure must be exerted on the bonnet when removing the last Hex Nut. Take note of the location of the warning tag attached to one stud.
- Step 2: Place Bonnet (12) in a bench vise and remove the Spirol pin (3) with the 1/4 " drift pin.
- Step 3: Remove the Bonnet (12) over stem (4). Remove the Springs (14), Spring Washers (13), and Centering Bushing (15) from Stem (4).
- Step 4: Remove Cotter Pin (30), Slotted Hex Nut (21), Disc Holder Retainer (20), and Disc Holder Assembly (18).
Note: Check the O-Ring (17) and Disc (19) on Disc Holder Assembly (18) for wear. The complete disc holder assembly must be replaced if o-ring or disc is worn.
- Step 5: With the Bonnet secured in the vise again, remove both guide Pins (28) with channel lock pliers.
- Step 6: Remove the Swivel Pad (6) by using a screw driver to pry up from the Bonnet, and remove Wiper Ring (7).
- Step 7: Through the top hole in Bonnet (12), push down gently on the Seal Washer (8) to dislodge the Stem Seal O-ring (9), Seal Sleeve (10) and Seal Retainer (11).

Assembly Procedure

DEGREE OF ASSEMBLY DEPENDS UPON TYPE OF REPAIR TO BE MADE.

REFER TO FIGURE 1 FOR THE FOLLOWING STEPS:

- Step 1: Install Disc Holder Assembly (18), Disc Holder Retainer (20), Slotted Hex Nut (21), and secure with Cotter Pin (30).
Note: Replace Disc Holder Assembly (18) if O-Ring (17) or Disc (19) is damaged.
- Step 2: Secure Valve Body (22) in vise. Install Gasket (16). Place Stem (4) and disc holder assembly into the valve until Disc Holder Assembly (18) rests against seat of valve body.
- Step 3: Slide Stem Centering Bushing (15) [large end first], over Stem (4) followed by the Springs (14) and Spring Washers (13).
- Step 4: With the stem seal assembly tool provided [Refer to Figure 2], place Seal Retainer (11), Stem Seal O-ring (9) and Seal Sleeve (10) over stem of the assembly tool. Press gently until the Seal O-ring (9) is around the Seal Sleeve (10). With these three components placed on the assembly tool, insert into Bonnet and push gently upward until they are in place. Remove the stem seal assembly tool. [See Fig. 2 for proper orientation of (9) and (10)].
Note: These three components must be lubricated with a good quality grease before installing.
- Step 5: Attach warning tag (24) over one stud. Gently push Bonnet (12) straight downward while maintaining pressure and engage the four Hex Nuts (29). Make sure the Hex Nuts have enough engagement before releasing pressure. Cross tighten Hex Nuts (29) to insure good alignment of Bonnet (12) to Body Gasket (16). Torque Hex Nuts evenly to values shown in torque table.

(OVER)

REFER TO FIGURE 1 FOR THE FOLLOWING STEPS:

- Step 6: Insert Wiper Ring (7) [shoulder end first] into Swivel Pad (6) and place on top of Bonnet.
- Step 7: Place Handle Centering Ring (5) [Large Side of Hole First - See Figure 3], over Stem (4). Place handle assembly over stem, align cross hole to Spirol Pin (3) and drive through the stem (4). Install the two Guide Pins (28). Open and close valve several times to seat the seals and insure valve is working properly.

Installation of New or Repaired Valve

REFER TO FIGURE 1 FOR THE FOLLOWING STEPS:

- Step 1: Safety equipment (i.e. gloves, goggles, clothing) must be worn before continuing with the next step.
- Step 2: Apply sealant on the pipe threads. Place valve in closed position before installation.
- Step 3: Take note that the direction of the flow is shown by the word INLET, stamped on the flange. The inlet must be pointed towards the upstream flow from the tank.
- Step 4: Open and close the valve several times to insure the valve is working properly.

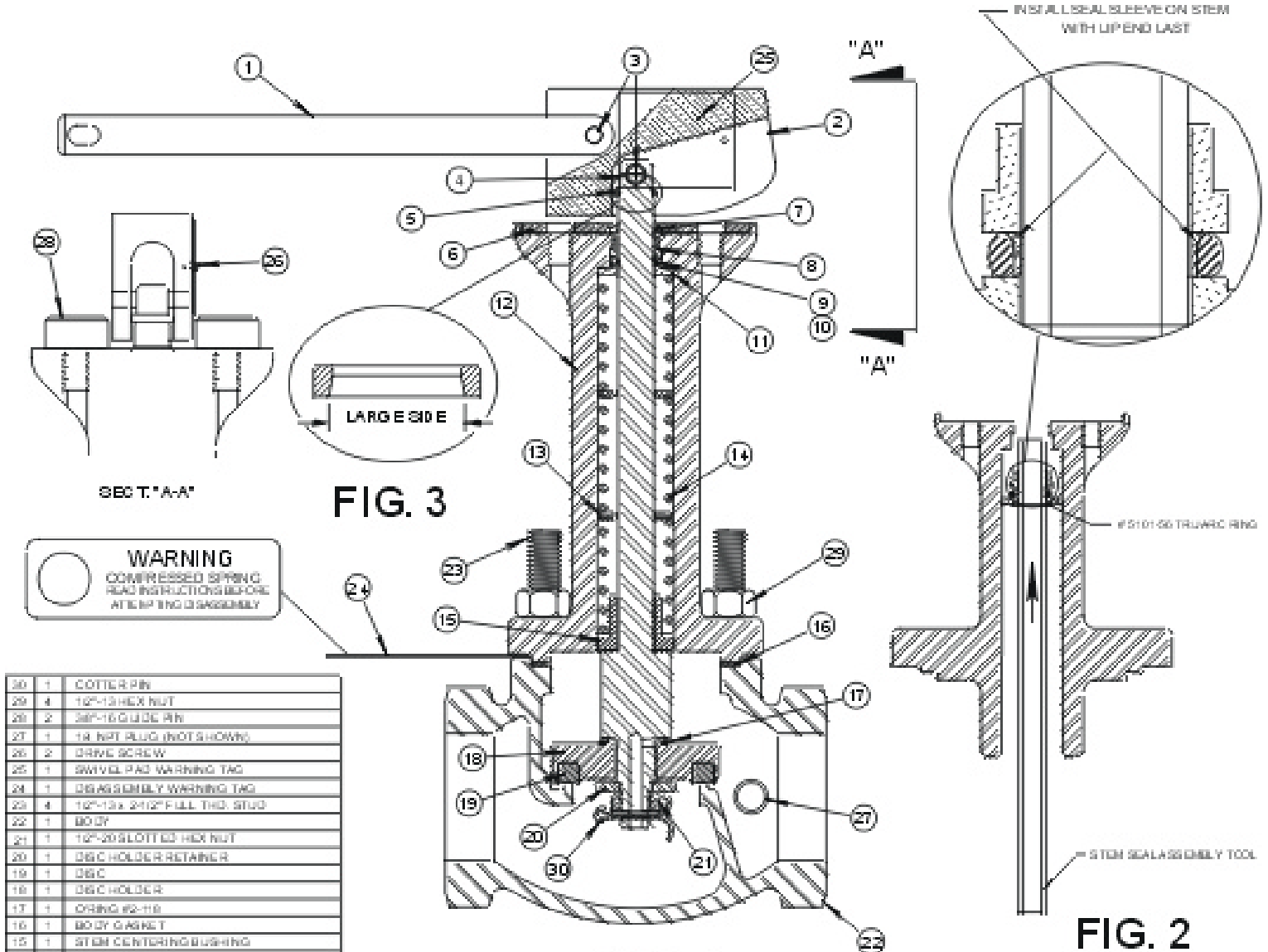

30	1	COTTER PIN
29	4	1/2"-13 HEX NUT
28	2	3/16"-16 GUIDE PIN
27	1	1/4 NPT PLUG (NOT SHOWN)
26	2	DRIVE SCREW
25	1	SWIVEL PAD WARNING TAG
24	1	ASSEMBLY WARNING TAG
23	4	1/2"-13 x 2 1/2" FULL THD. STUD
22	1	BODY
21	1	1/2"-20 SLOTTED HEX NUT
20	1	DBC HOLDER RETAINER
19	1	DBC
18	1	DBC HOLDER
17	1	O-RING #2-118
16	1	BODY GASKET
15	1	STEM CENTERING BUSHING
14	3	STEM SPRING
13	2	SPRING WASHER
12	1	BONNET
11	1	SEAL RETAINER
10	1	SEAL SLEEVE
9	1	STEM SEAL O-RING #5-207
8	1	SEAL WASHER
7	1	WIPER RING
6	1	SWIVEL PAD
5	1	HANDLE CENTERING RING
4	1	STEM
3	2	SPROL PIN
2	1	HANDLE SWIVEL
1	1	HANDLE
IMP	QTY	DESCRIPTION

FIG. 1

FIG. 2

TORQUE TABLE	
VALVE SIZE	TORQUE
1-1/4"	30 FT-LBS
2"	55 FT-LBS
3"	95 FT-LBS