

Installation and Operation

MANUFACTURED BY PGI INTERNATIONAL

Overview

The RSD-BV1 Manual Tank Valve Actuator is designed to be used with a radio controlled safety shutdown system on bobtail delivery vehicles equipped with cable operated internal valves, allowing the operator to remotely close the internal valve, as mandated by D.O.T. The heart of the BV1 is an internal electromagnet which may be disarmed remotely in an emergency situation, closing the internal valve.

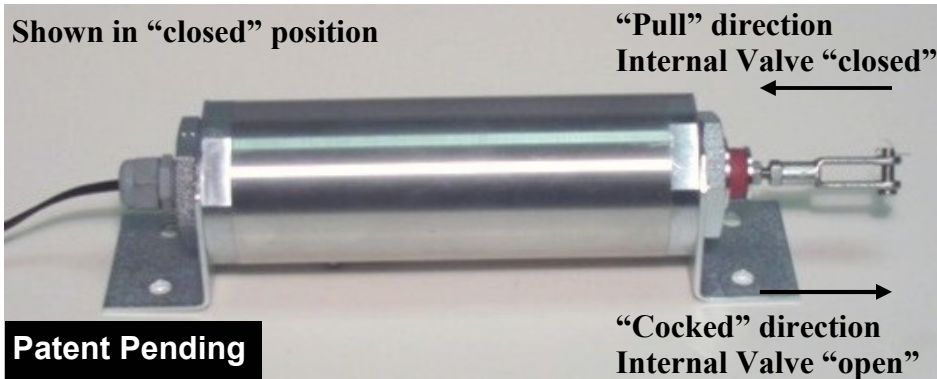

- **May be mounted in-line with or in place of your manual safety shutdown system**
- **Generates over 55 pounds of cable pull force for extremely reliable operation**
- **Rugged design and construction to withstand harsh environments**
- **Bracket design allows attachment to a frame or structural member at virtually any angle**

The electromagnet is mounted on a shaft connected to the valve cable at the clevis. When disarmed, the BV1 generates over 55 pounds of cable pull force on the Safety Trip Lever (STL) to trip all the manual levers to the CLOSED or OFF position.

Power is applied to the magnet only when the system is armed. When properly connected, the system is armed simply by setting the vehicle's parking brake, but the strength of the magnet alone is not enough to pull the shaft to the "cocked" or OPEN position. However, when the system is armed and the internal valve lever is "cocked" by the operator, the magnet has the power to **hold** the valve in that position. *Without* power to the magnet, all the manual levers remain operational, but will **not** be held in the "cocked" or OPEN position.

DO NOT LOOSEN OR REMOVE WIRE SEAL NUT. The end of the sheath must be flush with the nut.

**Weight: 9.2 lbs.
Power Requirements: 7 Watts, 12 VDC**

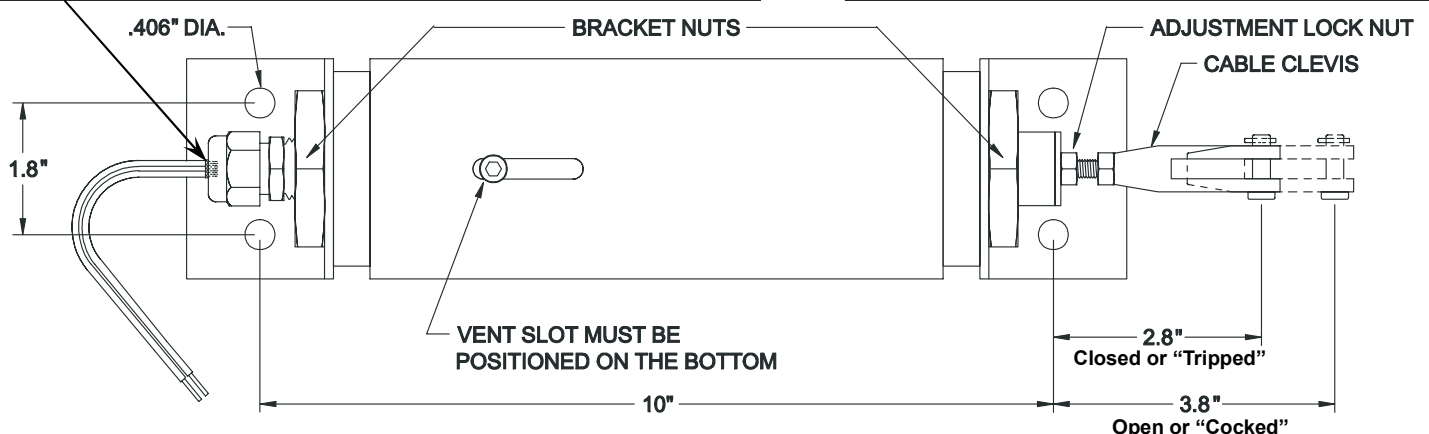

Installation and Operation

The RSD-BV1 may be installed **in place of** the manual safety shutdown lever (typically located near the cab) **or in parallel with** that system, depending on user preference, as shown schematically in Figure 1.

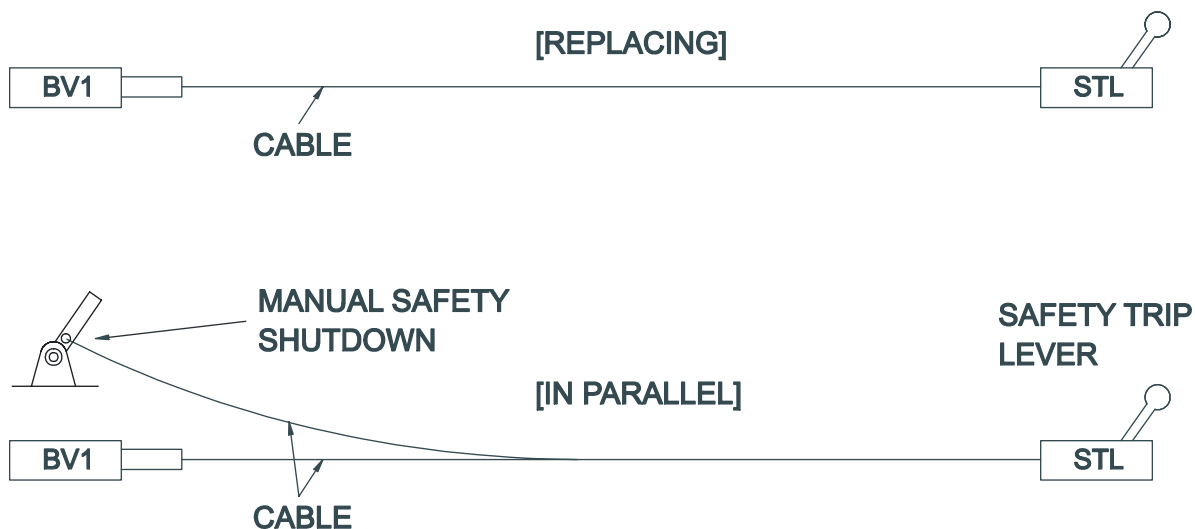

Figure 1

The RSD-BV1 contains an internal electromagnet that is mounted on a shaft which is spring biased in a “pull” direction. Without power to the electromagnet, the Safety Trip Lever (STL) on the manual lever assembly is in the “tripped” position (Internal Valve CLOSED, PTO OFF), as shown in Figure 2.

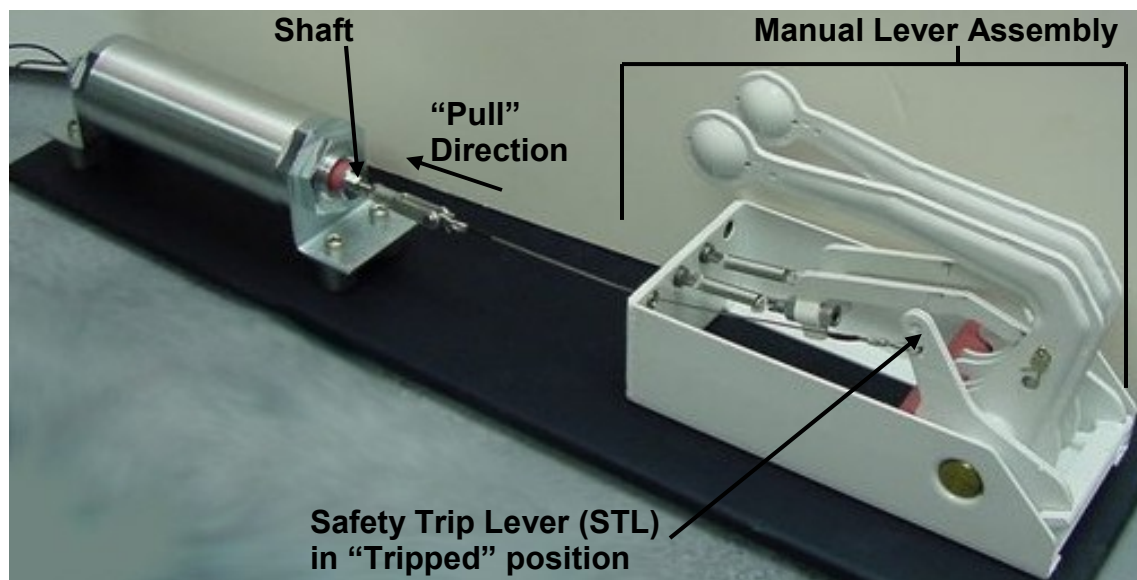

Figure 2

As the operator prepares to deliver product, he must arm the system and rotate the manual tank lever “Y” to the OPEN position, which carries the STL with it to the “cocked” position, as shown in Figure 3. Once the magnet is powered and the tank lever is moved to the “cocked” position, the magnet now has the power to *hold* the shaft in the “cocked” position until the system is shut down by the operator.

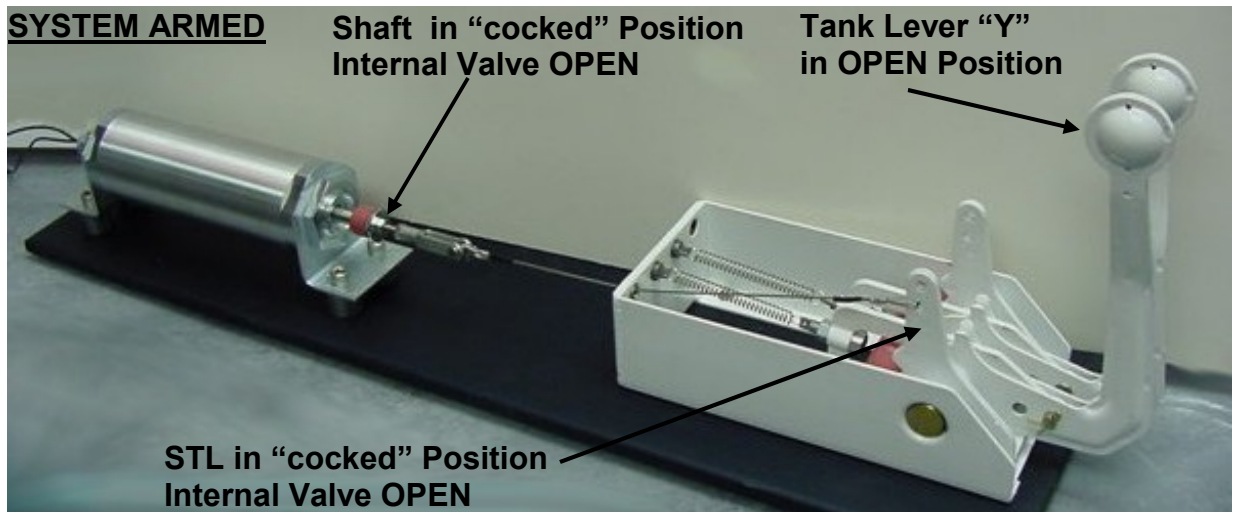

Figure 3

In an emergency situation, the radio remote safety system will remove power from the magnet in the BV1 which will release the shaft to "pull" the cable attached to the STL with 55 pounds of spring force through a stroke length of approximately 1 inch. That action will close all manual operating levers influenced by the STL, as shown in figure 4.

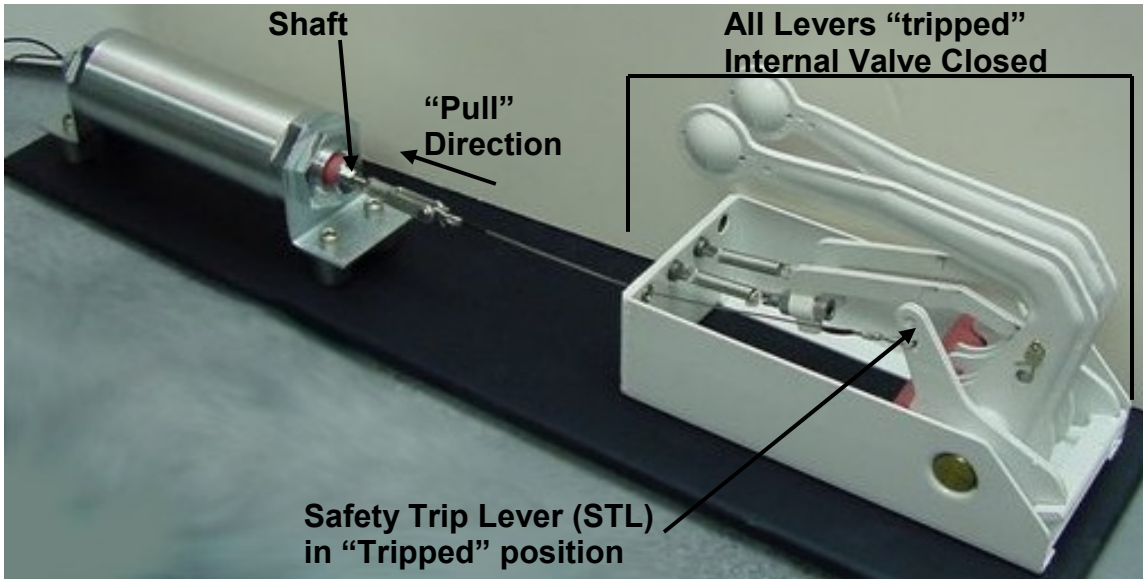
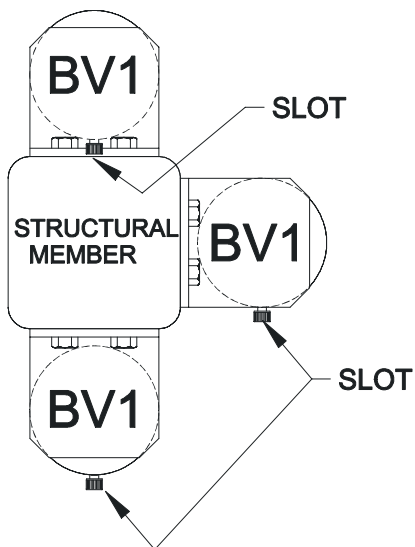

Figure 4

The BV1 **must** be mounted in a horizontal position. The swivel bracket will allow attachment to a frame or structural member at virtually any angle, as shown in Figure 5. Lock washers should be used on the bracket attachment nuts. The nuts should be tightened to a sufficient torque to prevent loosening of the bracket mount in road operating conditions.



WARNING!

After mounting, the BV1 cylinder must be rotated to a position where the slot in the cylinder is pointed down. This is necessary to allow the cylinder to operate properly and prevent any buildup of moisture in the mechanism.

Figure 5

To change the orientation of the cylinder, loosen the large Bracket Nuts on each end and rotate the cylinder so that the slot is pointed toward the ground.

After proper orientation of the cylinder, re-tighten the Bracket Nuts on each end of the cylinder with a large pipe or crescent wrench to at least 20 ft-lbs. **DO NOT USE A SMALL WRENCH OR CHANNEL LOCKS TO RE-TIGHTEN THE BRACKET NUTS.**

WARNING!

The cable that runs away from the clevis on the BV1 should not be more than about 15 degrees off the line of the BV1 shaft. To have the cable pull off center more than this will cause excessive wear to the internal BV1 mechanism **AND** could lead to improper operation of the device. If the cable must run off the line of the BV1 shaft, use a pulley or notched roller to change the cable direction.

Electrical Installation

Typical electrical installation will involve connecting one of the BV1 leads to chassis ground and the other to the 1—N.C. circuit of the RSD Receiver. The installer should make sure that all electrical connections are weatherproof and mechanically sound.

V. Warranty

Squibb-Taylor warrants the product identified herein to be free from defects in material and workmanship under normal use and service for **one year** from the date of purchase.

The owner's responsibility is for normal maintenance and any servicer's travel and labor charges.

This warranty applies only when the product is used for consumer use within the United States and Canada and is installed and used in accordance with all applicable national, state, and local codes, regulations, and laws.

This warranty shall not apply if the product has been subjected to unreasonable use, negligence, accident in transit, alteration, improper installation or misapplication.

Squibb-Taylor shall not be liable for any default or delay in performance under this warranty caused by any contingency beyond its control including without limitation to war, government restrictions or restraint, strikes, fire, flood, or a shortage or reduced supply of raw material.

There are no expressed warranties other than set forth above. All implied warranties, including the implied warranties of merchantability and fitness for a particular purpose, are limited to the duration of the expressed warranties set forth above. Liability for consequential damages under this warranty is excluded to the extent exclusion is permitted by law. This warning gives you certain rights and you may have other rights which vary from state to state.

While this information is presented in good faith and believed to be accurate, the manufacturer does not guarantee satisfactory results from reliance upon such information. Nothing contained herein is to be construed as a warranty or guarantee, expressed or implied, regarding the performance, merchantability, fitness or any other matter with respect to the products, nor as a recommendation to use any product or process in conflict with any patent. The manufacturer reserves the right, without notice, to alter or improve the designs or specifications of the products described herein.