



Installation, Operation, Maintenance Disassembly and Assembly Instructions for Models AL407P and AL409P Vapor or Liquid Service Valves

June 2000

Form FVC 023 - Rev. 1

KEEP THIS DOCUMENT WITH THE PRODUCT UNTIL IT REACHES THE END USER.

WARNING

Before installation or removal of any service valve, the system must be purged completely of all product. Use proper safety equipment at all times. An abundant supply of clean water must be readily available and easily accessible as a means of providing IMMEDIATE First Aid treatment for exposure to ammonia. To insure long term safe operation, the manufacturer recommends that under normal service conditions this product should be inspected at least once every five (5) years and be repaired or replaced as required. To prevent the accidental opening of any valve, never carry or grasp a valve by its handwheel or handle.

CAUTION: Contact with or inhalation of Liquid Anhydrous Ammonia or LP-Gas or their vapors can cause serious injury or death. Dispersment must be in accordance with local regulations.
For the proper handling and storage of Anhydrous Ammonia refer to ANSI Standard K61.1.
For the proper handling and storage of Liquefied Petroleum Gas refer to NFPA Pamphlet 58.

TOOLS REQUIRED:

Safety Equipment (i.e. gloves, goggles, and clothing), Screw Driver, 12" Adjustable Wrench, and 18" Pipe Wrench

Removal of any Service Valves for Repair or Replacement

REFER TO FIGURE 1 FOR THE FOLLOWING STEPS:

- Step 1: Safety equipment (i.e. gloves, goggles and clothing) must be worn before continuing with the next step.
- Step 2: Before removing valve from tank, place in FULL OPEN POSITION to insure all pressure is bled from system.
Note: See Warning at top of page.

Disassembly Procedure For Repair

REFER TO FIGURE 1 FOR THE FOLLOWING STEPS:

- Step 1: With valve secured in a bench vise, remove Bonnet (4) from the Body (6), which will expose the complete Bonnet and Stem Assembly. Note: It is important to inspect Disc Holder (10) rotation. If it does not rotate freely, do not use valve but consult your local dealer for instructions. Remove old Body Gasket (5).
- Step 2: Remove Screw (1), Washer (14), and Handwheel (2).
- Step 4: Remove Packing Nut (3), and Hat Gasket (8) over the end of Stem (9).
- Step 5: Rotate Stem (9) clockwise (CW) using Handwheel (2) if necessary, until stem is disengaged from Bonnet (4).
- Step 6: Before reassembly, clean and inspect the valve seat at (A). Clean all metal components with solvent and wipe or blow dry with air.

Assembly Procedure

REFER TO FIGURE 1 FOR THE FOLLOWING STEPS:

- Step 1: Install Disc (11), with injection marks against the Disc Holder (10), Disc Washer (12), and Disc Nut (13) to Disc Holder (10). Secure Disc Nut (13) to threads of Disc Holder (10) with center punch mark at thread interface.
- Step 2: Lubricate threads of stem with a good quality grease and install Stem (9) into Bonnet (4) until Disc Holder (10) rests against bottom of bonnet.
- Step 3: With the bonnet and stem assembly secured in a bench vise install the Hat Gasket (8) with small end first over stem (9).
- Step 4: Replace O-ring (7) in groove of Packing Nut (3).
- Step 5: Lubricate exposed surface of Stem (9) with John Crane Style 279A Packing Lubricant or equal.
- Step 6: Install Packing Nut (3) over Stem (9) and onto Bonnet (4). Tighten packing nut with torque wrench to 55 ft-lbs.
- Step 7: Secure Body (6) in vise. Place Body Gasket (5) over bonnet threads and lubricate threads with a good quality grease.
- Step 8: Install bonnet assembly into body and tighten with torque wrench to 55 ft-lbs.
- Step 9: Install Handwheel (2), Washer (14) and tighten Screw (1) on Stem (9).
- Step 10: Check stem packing and valve seat for leaks. Operate handwheel full open to full closed to insure smooth operation.

(OVER)

Installation of New or Repaired Service Valves

REFER TO FIGURE 1 FOR THE FOLLOWING STEPS:

- Step 1: Apply Teflon tape or sealant on 3/4" NPT threads, and place handwheel in full open position.
- Step 2: Install valve and tighten to desired position, taking caution to not overtighten.

Safety Tips for Shut-down and Storage

SAFETY TIPS FOR SHUT-DOWN AND STORAGE WHEN TANKS ARE NOT IN USE:

- Step 1: Make sure all valves are closed with any exposed outlets / inlets capped to keep out debris and moisture, which will help to prevent condensation or corrosion of internal parts.
- Step 2: Store tanks in accordance with federal, state, and local codes and manufacturer's instructions. Check periodically for leakage or excessive pressure build-up. Make corrections or repairs as necessary.

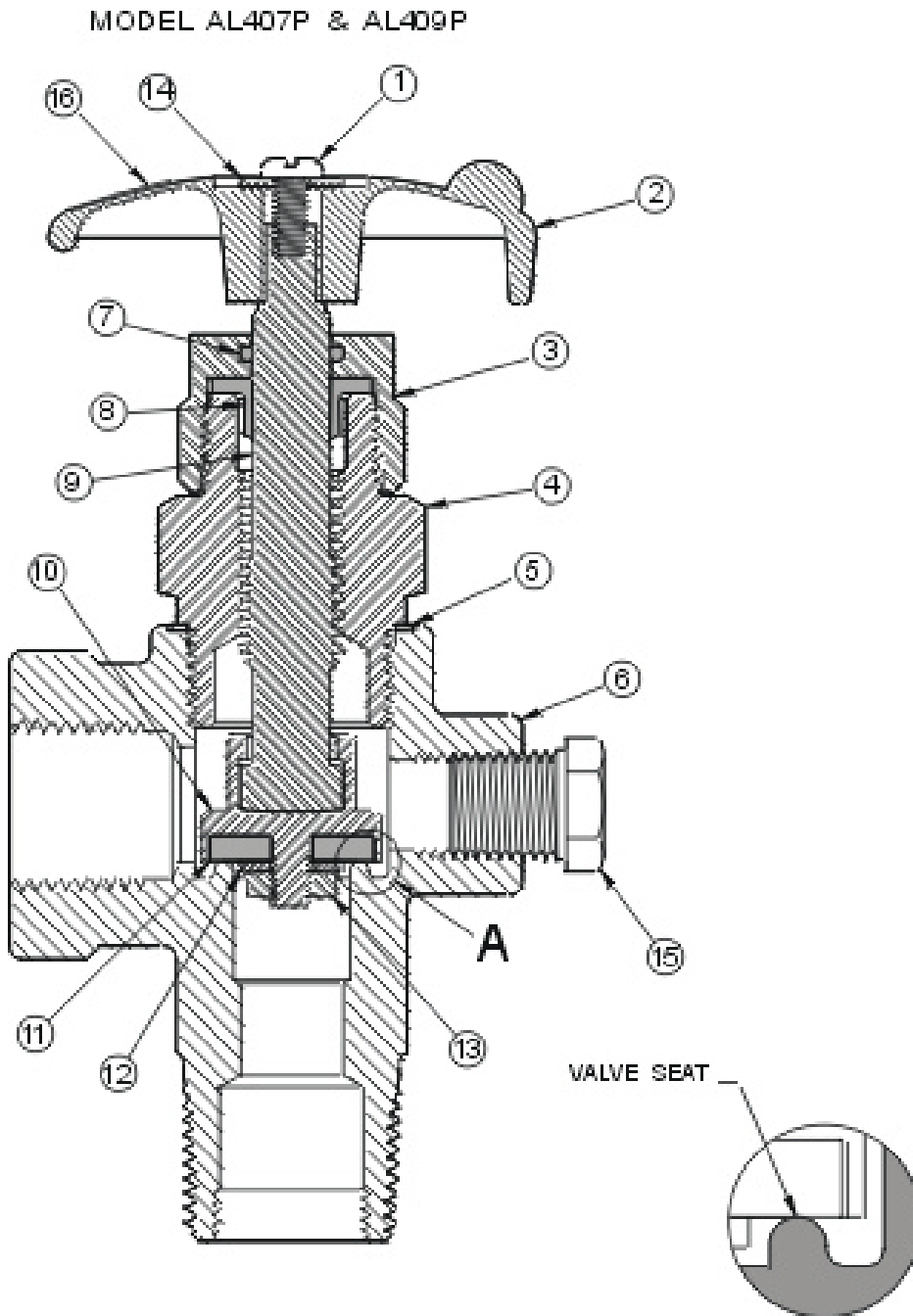

ITEM	QTY.	DESCRIPTION
16	1	WARNING LABEL
15	1	PLUG
14	1	WASHER
13	1	DISC NUT
12	1	DISC WASHER
11	1	DISC
10	1	DISC HOLDER
9	1	STEM
8	1	HAT GASKET
7	1	O-RING
6	1	BODY
5	1	BODY GASKET
4	1	BONNET
3	1	PACKING NUT
2	1	HANDWHEEL
1	1	SCREW

AVAILABLE KITS		
NUMBER	PARTS INCLUDED	ASSEMBLY PROCEDURE
407-0021	SEAL KIT ⑤ ⑦ ⑧ ⑪ ⑬	STEPS 1 THRU 10
407-1300	STEM & DISC HOLDER ASSY. ⑨ ⑩ ⑪ ⑫ ⑬	STEPS 2 THRU 10
407-1100	BONNET ASSY ③ ④ ⑦ ⑧ ⑨ ⑩ ⑪ ⑫ ⑬	STEPS 7 THRU 10

FIG 1

DETAIL A