



# Installation, Operation, Maintenance Disassembly and Assembly Instructions for Model A483

October 2001

Form FVC 049 - Rev. 1

**KEEP THIS DOCUMENT WITH THE PRODUCT UNTIL IT REACHES THE END USER.**

## WARNING

Before installation or removal of Sight Glass Fittings, the system must be purged completely of all product. Use proper safety equipment at all times. An abundant supply of clean water must be readily available and easily accessible as a means of providing IMMEDIATE First Aid treatment for exposure to ANHYDROUS AMMONIA. For LP-Gas service follow NFPA / ANSI 58 Standard for the Storage and Handling of Liquefied Petroleum Gases, plus all Local and State Safety Regulations. To insure long term safe operation, the manufacturer recommends that under normal service conditions this product should be inspected at least once a year and be repaired or replaced as required. Sight Glass should be replaced if any surface imperfections or scratches are found at any time.

**CAUTION:** Contact with or inhalation of Liquid Anhydrous Ammonia or L-P Gas or their vapors can cause serious injury or death. Dispersment must be in accordance with local regulations.  
For the proper handling and storage of Anhydrous Ammonia refer to ANSI Standard K61.1.  
For the proper handling and storage of Liquefied Petroleum Gas refer to NFPA Pamphlet 58.

**TOOLS REQUIRED:** Safety Equipment (i.e. gloves, goggles, and clothing), 24" pipe wrench, a 1/8 hex allen wrench, and (2) 1/4" diameter pins x 1" long

## Removal of Valve for Repair or Replacement

REFER TO FIGURE 1 FOR THE FOLLOWING STEPS:

- Step 1: Safety Equipment (i.e. goggles, gloves and clothing) must be worn before continuing with the next step.
- Step 2: Before removing valve insure that all pressure is bled from the system.  
NOTE: See Warning at top of page.

## Disassembly Procedure for Repair

REFER TO FIGURE 1 FOR THE FOLLOWING STEPS:

- Step 1: With tee secured in a bench vise, remove Cover Hinge Pin (8). This allows the Cover Plate (7) and Torsion Spring (9) to be removed.
- Step 2: Remove Set Screw (6) from Body (1).
- Step 3: Remove Sight Glass Holder (2) using the 1/4 diameter pins inserted into the spanner wrench holes on the top face of Sight Glass Holder (2). Use screw driver or wrench handle between the 1/8 diameter pins and rotate counter-clockwise (CCW).
- Step 4: Remove Sight Glass (3) and Gasket (5) from Sight Glass Holder (2).
- Step 5: Remove O-Ring (4) from Body Cavity (1).

## Assembly Procedure

REFER TO FIGURE 1 FOR THE FOLLOWING STEPS:

- Step 1: Install O-Ring (4) into Body Cavity (1) and lubricate O-Ring with good quality grease compatible with service conditions.
- Step 2: Place Sight Glass (3) into Body Cavity (1) centered on top of O-Ring (4).  
CAUTION: Do not scratch or drop Sight Glass. Handle with care.
- Step 3: Lubricate both sides of Gasket (5) and install into Sight Glass Holder (2).
- Step 4: Install Sight Glass Holder (2) into threads of Body Cavity (1), and rotate carefully clockwise (CW). This will install the Sight Glass (3) into the Sight Glass Holder (2).
- Step 5: Rotate the Sight Glass Holder (2) until it bottoms out against the bottom of Body Cavity (1).
- Step 6: Tighten the Sight Glass Holder (2) using the 1/4 diameter pins in the spanner wrench holes on the face of the Sight Glass Holder (2).  
NOTE: The inside face of the Sight Glass (3) will now be in sealing contact with the O-Ring (4). Pressure test fitting before returning to service.

(OVER)

## Assembly Procedure (cont'd)

### REFER TO FIGURE 1 FOR THE FOLLOWING STEPS:

- Step 7: Install Torsion Spring (9) into Spring Cavity of Body (1), with one leg of the torsion spring placed in the small hole at the bottom of the Spring Cavity.
- Step 8: Install the Cover Plate (7) with the other leg of the Torsion Spring inserted in the small hole provided on the Cover Plate (7).  
NOTE: The counterbored hole on the Cover Plate (7) should face upward.
- Step 9: Rotate the Cover Plate (7) over the top of the Cover Stop Pins (10) to center the Cover Hinge Pin hole over the Torsion Spring (9).
- Step 10: Install the Cover Hinge Pin (8) and tighten with 1/8 hex allen wrench.
- Step 11: Rotate the Cover Plate (7) to insure that the Torsion Spring will automatically return the Cover Plate against the stop pin when released.

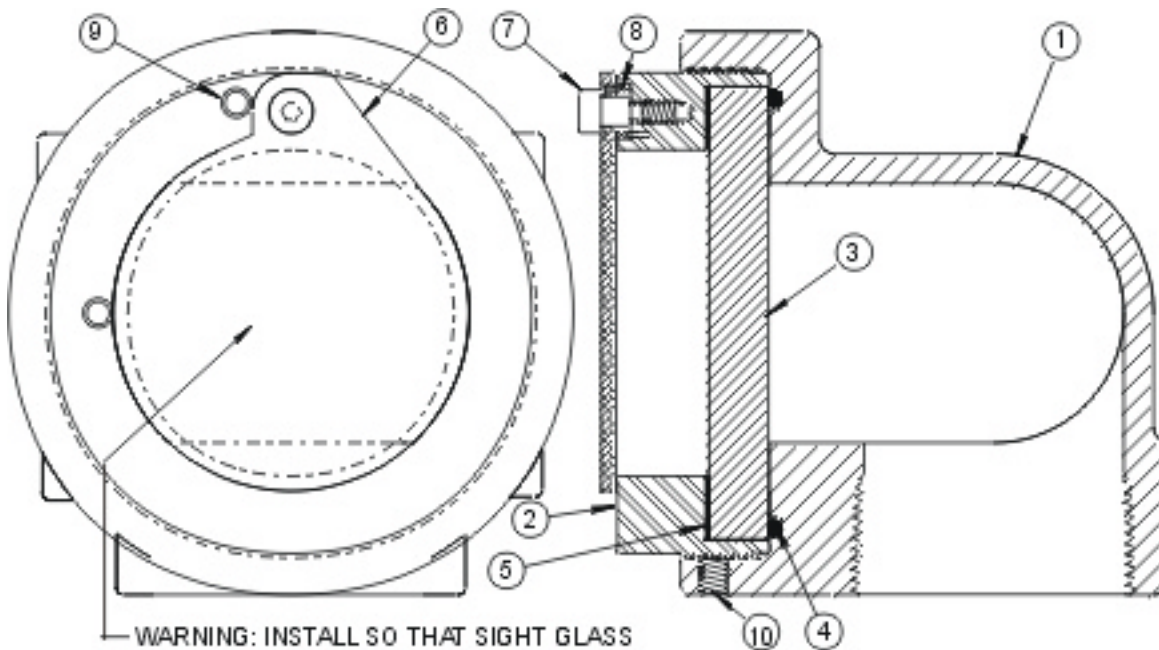

**FIG. 1**

\* INCLUDED IN REPAIR  
KIT #SGT-0002

NO.	QTY	DESCRIPTION
10	2	COVER STOP PINS
*	9	TORSION SPRING
8	1	COVER HINGE PIN
7	1	COVER PLATE
6	1	SET SCREW
*	5	GASKET
*	4	O-RING
*	3	SIGHT GLASS
2	1	SIGHT GLASS HOLDER
1	1	TEE BODY
NO.	QTY	DESCRIPTION