

# Sight Glass Inspection Tee

So You Can Inspect What You Expect

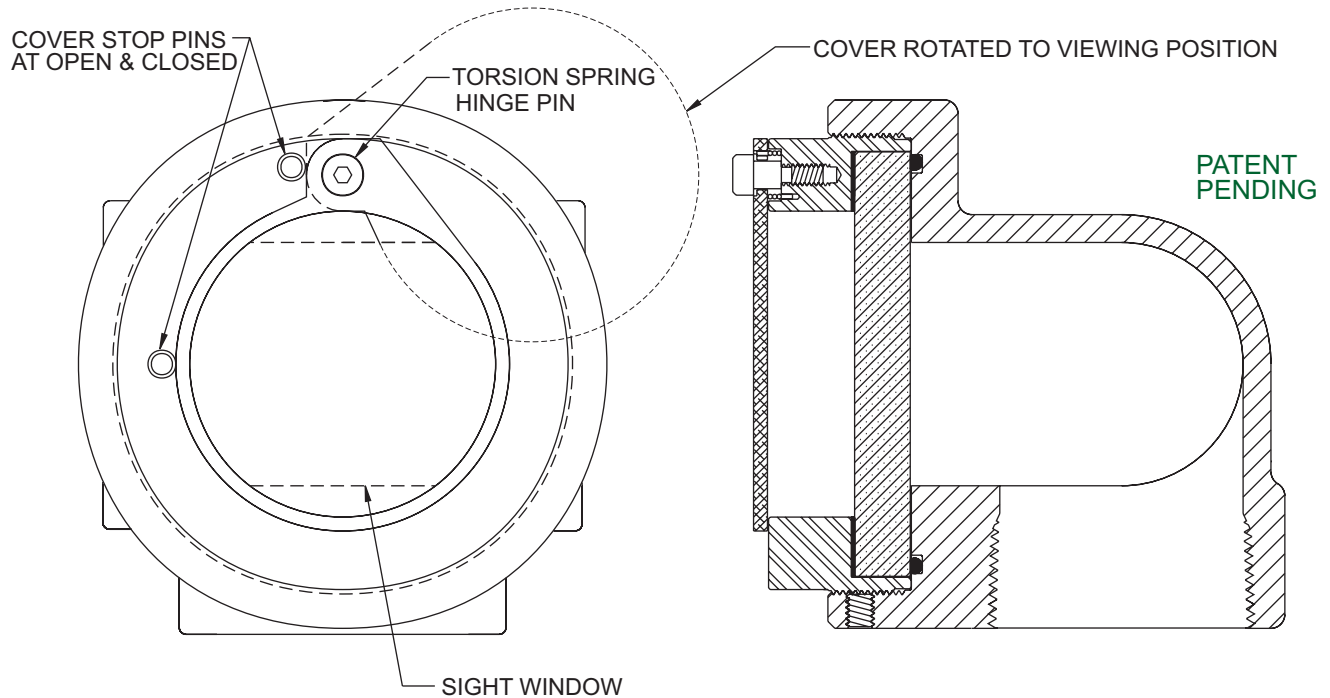

**INSPECT INLINE BACK CHECKS AND EXCESS FLOW VALVES WHILE PRODUCT IS FLOWING.**

## FEATURES

- Tempered Lime Glass For Max. Strength
- Design Tested to 3000 PSI (Max. W.P. = 400 PSI)
- Spring Return Sight Glass Cover (Always covers sight glass when released)
- Field Serviceable
- 2" FNPT Standard Tee Connections
- Same Flow Rate as Standard Tee



MANUFACTURED BY PGI INTERNATIONAL

214.357.4591  
800.345.8105  
squibb@squibbtaylor.com

# MODEL A483 - 2" NPT TEE

