

# Hi-Flo Soft Seat Back Check

*Have you experienced the TWO biggest problems with back checks?*

1. A Metal to Metal Seat that LEAKS
2. A Check Disc that goes downstream

*These problems are completely **ELIMINATED** when you use the **Squibb-Taylor Back Check!***

## FLOW TEST DATA

MODEL	SIZE (NPT)	FLOW (GPM @ 10 PSI)	
		NH <sub>3</sub>	LP-Gas
AL 1727	1-1/4"	72	79
AL 1728	2"	166	183
AL 1729	3"	332	366

PATENT  
PENDING

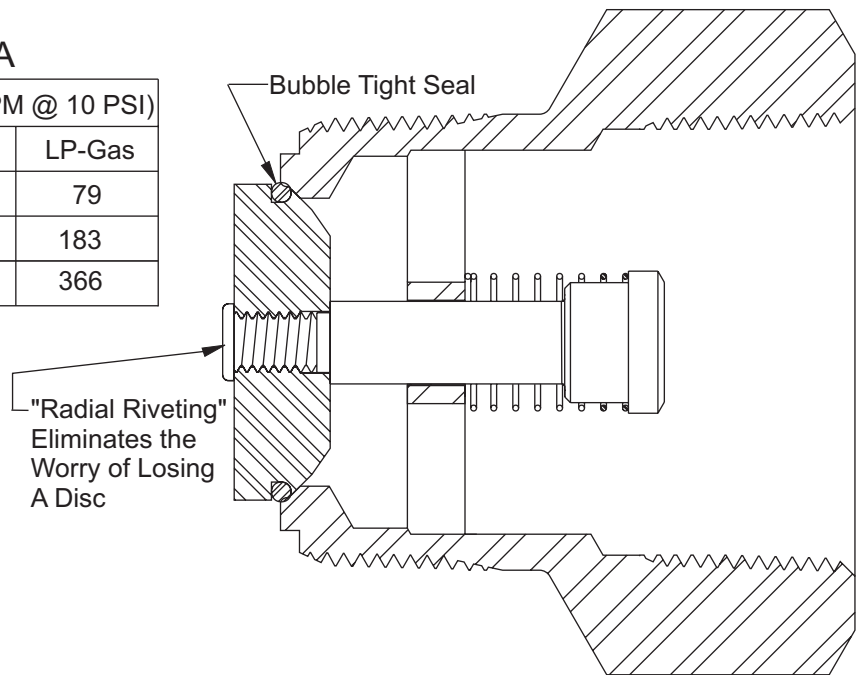

## FEATURES

- Elastomer soft seat that is UL Listed for NH<sub>3</sub> and LP-Gas, and seals bubble tight.
- Stem with a "Radial Riveted Button" that secures the Check Disc like it was welded.
- Field Replaceable O-Ring Seat

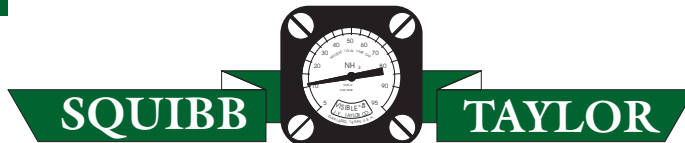

MANUFACTURED BY PGI INTERNATIONAL

214.357.4591  
800.345.8105  
squibb@squibbtaylor.com