



Installation, Operation, Maintenance Disassembly and Assembly Instructions for Model AL404 Liquid Level Vent Valve

February 2001

Form FVC 045 - Rev.1

KEEP THIS DOCUMENT WITH THE PRODUCT UNTIL IT REACHES THE END USER.

WARNING

Before installation or removal of any tank valve, the system must be purged completely of all product. Use proper safety equipment at all times. An abundant supply of clean water must be readily available and easily accessible as a means of providing immediate first aid treatment for exposure to anhydrous ammonia. For LP-Gas service follow NFPA / ANSI 58 Standard for the Storage and Handling of Liquefied Petroleum Gases, plus all Local and State Safety Regulations. To insure long term safe operation, the manufacturer recommends that under normal service conditions this product should be inspected at least once every five (5) years and be repaired or replaced as required. To prevent the accidental opening of any valve, never carry or grasp a valve by its handwheel or handle.

CAUTION: Contact with or inhalation of Liquid Anhydrous Ammonia or L-P Gas or their vapors can cause serious injury or death. Dispersment must be in accordance with local regulations. For the proper handling and storage of Anhydrous Ammonia refer to ANSI Standard K61.1. For the proper handling and storage of Liquefied Petroleum Gas refer to NFPA Pamphlet 58.

TOOLS REQUIRED: Safety Equipment (i.e. gloves, goggles, and clothing), 1" Open End Wrench, a Blade Type Screwdriver, and a 14" Adjustable Wrench.

Removal of Valve for Repair or Replacement

REFER TO FIGURE 1 FOR THE FOLLOWING STEPS:

- Step 1: Safety Equipment (i.e. gloves, goggles, and clothing) must be worn before continuing with the next step.
- Step 2: Before removing the Liquid Level Vent Valve, place in FULL OPEN POSITION, by turning the handle (CCW).
- Step 3: Open the bleed valve installed in the side body port and bleed all pressure from the Tank or Piping.

NOTE: See Warning at top of page.

Disassembly Procedure for Repair of Valve

REFER TO FIGURE 1 FOR THE FOLLOWING STEPS:

- Step 1: With the valve secured in a bench vise, remove the Panhead Screw (6) and Washer (7) using a blade type screw driver. Remove Handwheel (5) from Stem (2).
- Step 2: Remove the hexagonal Bonnet (3) using a 1" open end wrench.
- Step 3: To remove the Stem (2) from the Valve Body (1) place the Handwheel (5) on the flats of the Stem (2) and rotate counterclockwise (ccw).

Step 4: Remove the O-Ring (4) from the Stem (2).

Step 5: Using a flashlight inspect the internal bore and Body seat area for any scratches or debris attached to the seat. Using an aerosol spray cleaner, clean out the internal bore of the Body to remove any foreign substance along the walls or on the internal threads or seat.

NOTE: If scratches or draw marks are found at the Body seat area the valve may leak when pressure tested. This may be cause to replace the valve.

Step 6: Clean the threads on the Stem and Bonnet with an aerosol spray cleaner, including the external bonnet threads on the Body.

(OVER)

REFER TO FIGURE 1 FOR THE FOLLOWING STEPS:

- Step 1: Install O-Ring (4) into groove on Stem (2).
- Step 2: Lubricate Stem threads with a small amount of thread lubricant and install Stem into Body (1). Place Handwheel (5) onto flats of Stem (2) and rotate clockwise (cw) until stem intersects Body seat. Note: Do not use a wrench on the Handwheel to seat valve. The valve will seat properly using one hand to tighten.
- Step 3: Install Bonnet (3) over Stem (2) and thread onto Body bonnet threads. Torque the Bonnet (3) to 25 ft-lbs.
- Step 4: Place Handwheel (5) on flats of Stem (2) and secure with Panhead Screw (6) and Washer (7).
- Step 5: Test valve with air to be bubble tight before returning to service.

Installation of New or Repaired Liquid Level Vent Valves

- Step 1: Apply Teflon tape or pipe sealant on male pipe threads of valve. Place valve in Closed position.
- Step 2: Install Bleed Valve and Pressure Gage into side body ports.
- Step 3: Install complete valve assembly in to tank or piping, taking care to not overtighten.
- Step 4: Open valve and check for leaks at all threaded connections.

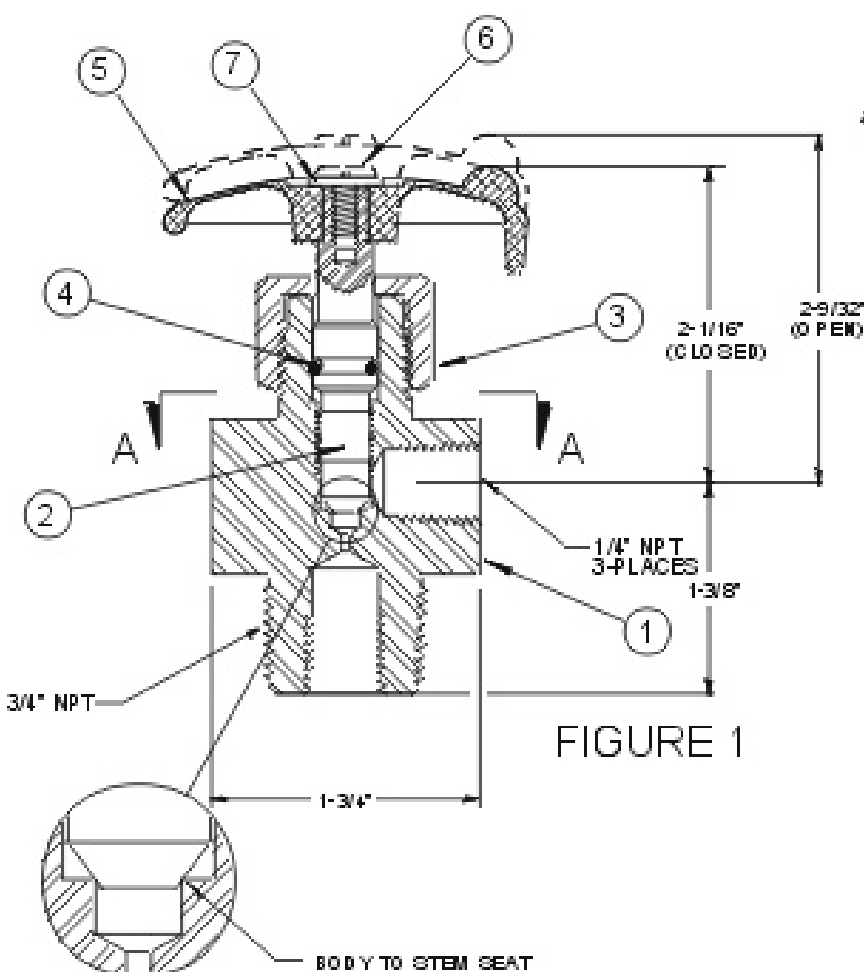
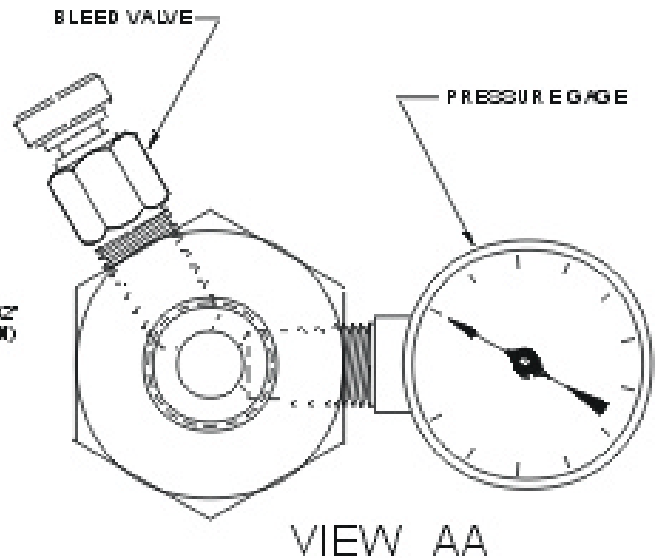

FIGURE 1



VIEW AA

+ SEAL KIT NO. 404-0022

| | | |
|-----|---|------------------|
| 7 | 1 | WASHER |
| 6 | 1 | PAN HEAD SCREW |
| 5 | 1 | HANDWHEEL |
| + 4 | 1 | STEM SEAL O-RING |
| 3 | 1 | BONNET |
| 2 | 1 | STEM |
| 1 | 1 | BODY |

ENCL 0212 DR 001 F01'00 IN

MODEL AL 404