

# 1805 Series Relief Valves

## Introduction



### WARNING

Fisher relief valves must be installed, operated, and maintained in accordance with federal, state, and local codes, rules, and regulations and Fisher instructions.

If the spring case develops a leak or if the outlet continuously vents gas, service to the unit may be required. Failure to correct trouble could result in a hazardous condition.

Call a gas service man to service the relief valve. Only a qualified person must install or service the unit.

The 1805 Series relief valves are primarily designed for use in farm tap applications where a safety relief valve is needed between the first and second stage regulators. The 1805 Series is suitable for service on natural gas, air, propane, or any operating medium that is not corrosive to the internal parts. Relief pressure ranges from 5 to 125 psi. Maximum pressure, including buildup, is 150 psi.

Table 1. Type Number Description

TYPE NUMBER	SIZE, INCHES	DISTINCTIVE CONSTRUCTION FEATURES
1805-1	3/4 & 1	Zinc spring case
1805-2	3/4 & 1	Cast iron spring case, closing cap with 1/4" NPT vent placed over the adjusting screw
1805-3	1-1/2 & 2	Cast iron spring case, closing cap with 1/4" NPT vent placed over the adjusting screw
1805-4	3/4 & 1	Cast iron spring case
1805-5	1-1/2 & 2	Cast iron spring case
1805-6	3/4 & 1	1805-1 with screen in outlet
1805-7	3/4 & 1	Cast iron spring case, closing cap with 1/4" NPT vent placed over the adjusting screw, screen in outlet



W0611

Figure 1. Type 1805 Relief Valve

## Installation

After uncrating, check the relief valve for shipping damage. Remove pipe scale and other foreign material from the connecting pipeline. Coat the male pipe threads with a suitable pipe compound. The unit can be installed in any position as long as the flow is in the direction indicated by the arrow cast on the body.

Protect the outlet and vents from entrance of rain, snow, or other foreign material that may plug them.

Outdoor installations should include a rain cap over the vents and outlet if they point upward. Periodically check the openings to ensure that they are not plugged.

Protect the relief valve against damage from vehicles or other external sources.

Operative temperature range for the 1805 Series relief valves is -20°F to +150°F.



# 1805 Series

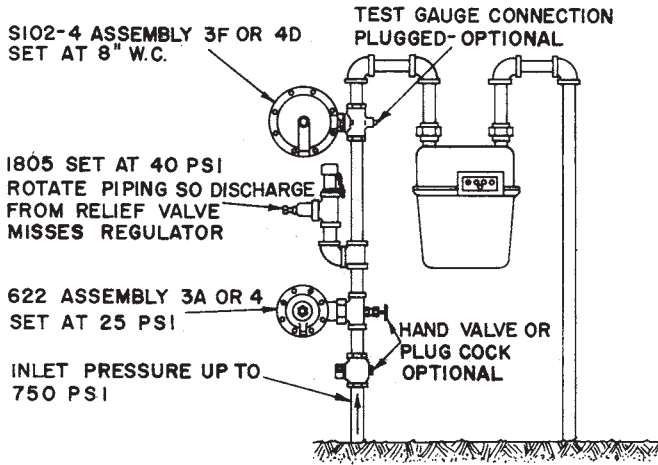

AF9932

Figure 2. Typical Farm Tap Installation

## Vents



### WARNING

**Venting gas may accumulate and be an explosion hazard under enclosed conditions such as in pit or underground installations. Install remote vent lines to carry gas to a safe area.**

If remote vent lines are necessary, use the Types 1805-2, -3, or -7 which have 1/4" NPT vent connections in the closing cap. Remove the screen, if one is present in the outlet, and install remote vent lines in the outlet and closing cap openings. Remote vent lines must have the largest practical diameter. The vent lines should be as short as possible with a minimum number of bends or elbows.

## Overpressure

Relief pressure ratings are from 5 to 125 psi. The maximum inlet pressure, including buildup, is 150 psi. System operation within these limitations does not eliminate the possibility of damage from external sources or from debris in the gas line. The relief valve should be inspected for damage regularly and after any overpressure condition.

## Adjustment

The range of allowable pressure settings is stamped on the spring case (Types 1805-1, -2, -4, -6, and -7) or on the nameplate (Types 1805-3 and -5). If a pressure setting beyond the indicated range is required, substitute the appropriate spring. Be sure to

label the relief valve to indicate the new pressure range. Always use a pressure gauge to monitor pressure when making adjustments.

1. On Types 1805-2, -3, and -7 remove the closing cap (key 17).
2. Loosen hex nut (key 15).
3. To increase the relief setting, turn the adjusting screw (key 14) clockwise. To decrease the relief setting, turn the adjusting screw counterclockwise.
4. Tighten the hex nut.

## Principle of Operation

See figure 3. Relief valves respond to changes in upstream pressure. If upstream pressure increases and exceeds the relief valve setting, the valve will open and allow gas to vent to the atmosphere. When upstream pressure returns to normal level (below the setting of the relief valve), the relief valve automatically closes and normal system operation resumes.

In the 1805 Series relief valves, the upstream pressure registers underneath the diaphragm. Gas reaches the diaphragm through the space between the O-ring holder and the valve guide orifice in 3/4" and 1" bodies or through registration holes in the valve guide orifice in 1-1/2" and 2" bodies (see figure 4). When the upstream pressure increases beyond the spring setting, the force on the diaphragm overcomes spring

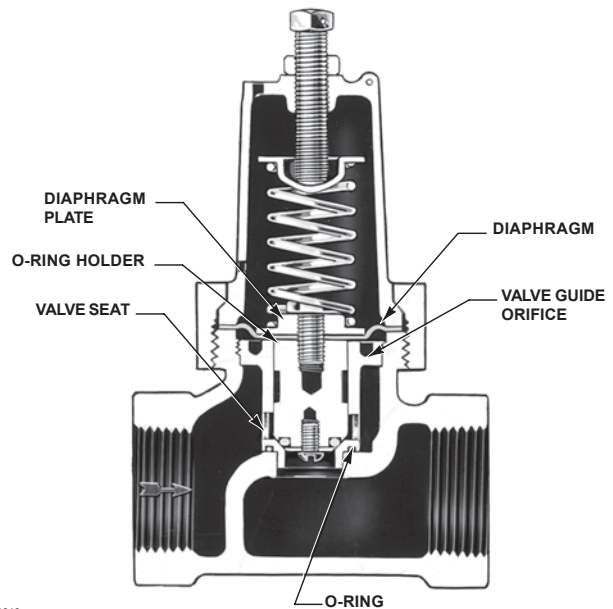

W0613

Figure 3. Type 1805-1

compression. The O-ring holder moves upward, carrying the O-ring away from the valve seat. This opens the flow line, allows gas to flow to the atmosphere, and relieves the overpressure condition. When upstream pressure registered on the diaphragm decreases to a level below that of the spring setting of the relief valve, the spring force pushes the diaphragm plate and O-ring holder toward the valve seat. Contact between O-ring and valve seat prevents further flow to atmosphere.

## Maintenance



### WARNING

**To avoid personal injury and equipment damage, isolate the relief valve from all pressure. Cautiously release pressure from the relief valve before attempting disassembly.**

Due to normal wear that may occur in relief valves, the O-rings and diaphragm must be inspected periodically and replaced as necessary. The frequency of inspection and replacement depends upon the severity of service conditions or the requirements of state and federal laws. Instructions are given below for disassembly of the relief valve and replacement of the O-rings and diaphragm. The 1805 Series relief valves do not have to be removed from the pipeline to inspect internal parts. Refer to figure 4 while servicing the relief valves.

1. To ease spring compression, remove the closing cap (key 17, Types 1805-2, -3, and -7), loosen the hex nut (key 15), and turn the adjusting screw (key 14) counterclockwise.

2. Unscrew the union nut (key 16) and remove it with the spring case (key 13), spring (key 11), and upper spring seat (key 12).

3. Pull the O-ring holder (key 4) out of the valve guide orifice (key 2).

4. Remove the diaphragm cap screw (key 10) from the O-ring holder. Take off the diaphragm plate (key 9) and inspect the diaphragm (key 8).

5. Take the machine screw (key 7) out of the opposite end of O-ring holder, remove the O-ring washer (key 6) and inspect the O-ring (key 5).

6. Remove the valve guide orifice (key 2) from the body and check the Tetra-seal\* O-ring (key 3).

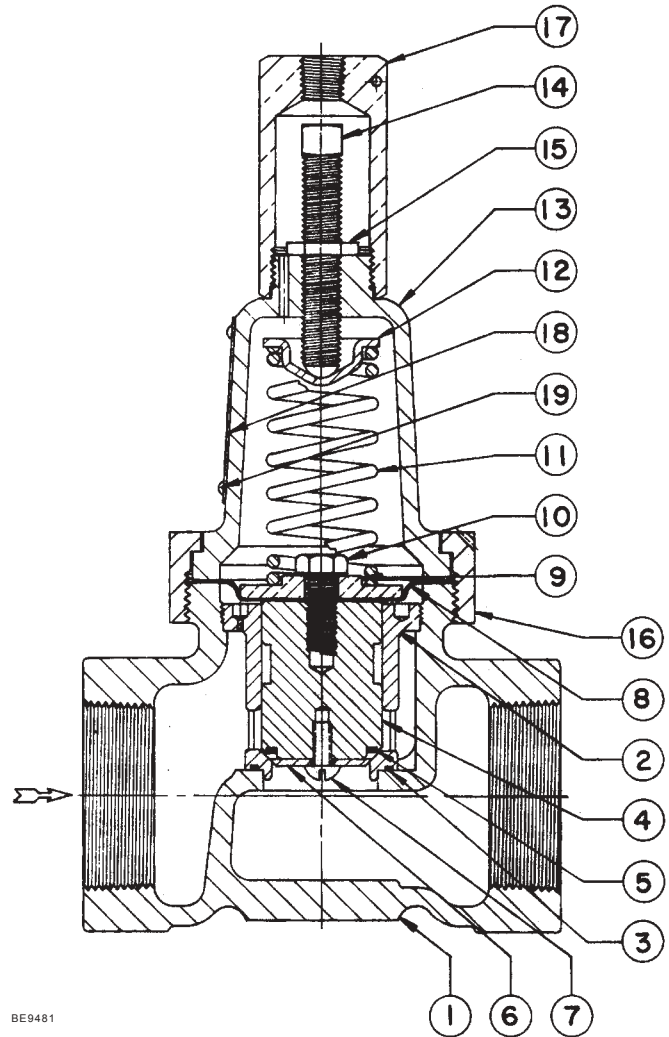

Figure 4. Type 1805-3

7. Reassemble the relief valve in reverse order of the above steps. To ensure proper slack in the diaphragm, tighten the union nut finger-tight only. Turn the adjusting screw clockwise to apply some spring force to the diaphragm. Complete the tightening of the union nut.

## Type Number

When corresponding with a Fisher representative or the factory concerning these relief valves, include the type number and all other pertinent information stamped on the spring case, closing cap, or on the nameplate. Specify the eleven-character part number when ordering new parts from the following parts list.

\*Trademark of Goshen Rubber Company.

# 1805 Series

## Parts List

Key	Description	Part Number	Key	Description	Part Number
1	Valve Body 1805-1, -2 & -4 3/4" NPT Cast iron Malleable iron WCB Steel Heat-treated for sour gas corrosion resistance capability (1) For other than sour gas applications 1" NPT Cast iron Malleable iron 1F1921 19062 WCB Steel Heat-treated for sour gas corrosion resistance capability For other than sour gas applications 1805-3 & -5 1-1/2" cast iron 2" cast iron 1805-6 & -7 3/4" cast iron 1" cast iron	1E6211 19012 1F1920 19062  1R6879 X0022 1R6879 X0012  1E6212 19012  2U7426 X0012 2U7426 22012  1E8240 19012 1E8243 19012  1H2425 19012 1H2426 19012	11	Spring, steel, Cd pl 3/4" & 1" body size 5-35 psig 10-60 psig 20-125 psig 1-1/2" & 2" body size 5-20 psig 10-50 psig 35-125 psig	1B9860 27212 1B7883 27022 1B7884 27022  1D8923 27022 1D6659 27022 1E5436 27142
2	Valve Guide Orifice, aluminum 3/4" & 1" body size 1-1/2" & 2" body size	1K3147 09012 1N9399 09012	12	Upper Spring Seat, steel plated 3/4" & 1" body size 1-1/2" & 2" body size	1B7985 25062 1D6671 25072
3*	Tetraseal/O-ring, nitrile 3/4" & 1" body size 1-1/2" & 2" body size	1K3148 06992 1N9403 06562	13	Spring Case 3/4" & 1" body size Zinc Cast iron 1-1/2" & 2" body size Cast iron	2E6219 44012 2E7708 19012  2E8249 19042
4	O-Ring Holder, aluminum 3/4" & 1" body size 1-1/2" & 2" body size	1E6216 09092 1E8246 09092	14	Adjusting Screw 3/4" & 1" body size Steel, Cd pl Brass 1-1/2" & 2" body size Brass	1E6221 28982 1E7709 14012  1E5432 14012
5*	O-Ring, nitrile 3/4" & 1" body size 1-1/2" & 2" body size	1D2888 06992 1C5622 06992	15	Hex Nut, steel pl 3/4" & 1" body size 1-1/2" & 2" body size	1A9463 24122 1D6677 28982
6	O-Ring Washer, SST 3/4" & 1" body size 1-1/2" & 2" body size	1D3359 35072 1E8242 35072	16	Union Nut, malleable iron 1805-1 and -6 1805-2, -4 and -7 1805-3 and -5	1E4711 19062 1C4249 19062 1E7666 19062
7	Machine Screw, Zn pl steel 3/4" & 1" body size For sour gas corrosion resistance capability For other than sour gas applications 1-1/2" & 2" body size	1P1001 X0012 1P1001 28982 1A8991 28992	17	Closing Cap, brass 1805-2 and -7 1805-3	1E7706 14012 1E8239 14012
8*	Diaphragm, nitrile 3/4" & 1" body size 1-1/2" & 2" body size	1E6217 02052 1E8241 02052	18	Name Plate, aluminum 1-1/2" & 2" body size	1E2401 11992
9	Diaphragm Plate, brass 3/4" & 1" body size 1-1/2" & 2" body size	1E6218 14012 1E8247 14012	19	Drive Screw, steel pl (4 required) 1-1/2" & 2" body size	1E5017 28982
10	Cap Screw, steel pl 3/4" & 1" body size 1-1/2" & 2" body size	1D1946 28992 1E7603 24052	20	Screen, monel (not shown) 1805-6 and -7	1E5648 43122
			21	Snap Ring, SST (not shown) 1805-6 and -7	1E5649 37022
			22	NACE Tag, 18-8 stainless steel (not shown)	19A6034 X012
			23	Tag Wire, 304 stainless steel (not shown)	1U7581 X0022

\*Recommended spare part.

1. As detailed in National Association of Corrosion Engineers (NACE) standard MR-01-75.

Fisher is a mark owned by Fisher Controls International, Inc., a business of Emerson Process Management. The Emerson logo is a trademark and service mark of Emerson Electric Co. All other marks are the property of their respective owners.

The contents of this publication are presented for informational purposes only, and while every effort has been made to ensure their accuracy, they are not to be construed as warranties or guarantees, express or implied, regarding the products or services described herein or their use or applicability. We reserve the right to modify or improve the designs or specifications of such products at any time without notice.

Fisher does not assume responsibility for the selection, use or maintenance of any product. Responsibility for proper selection, use and maintenance of any Fisher product remains solely with the purchaser.

For information, contact Fisher:  
Marshalltown, Iowa 50158 USA  
McKinney, Texas 75070 USA  
28320 Gallardon, France  
40013 Castel Maggiore (BO), Italy  
Sao Paulo 05424 Brazil  
Singapore 128461

