

# BLACKMER PARTS LIST

960401  
Page 1 of 2

**PARTS LIST**  
**501-A01**

## PUMP MODELS: LGF1E, LGB1E, LGF1PE, LGB1PE

and Discontinued Models

LGF1D, LGB1D, LGF1PD, LGB1PD, LGF1C, LGB1C, LGF1PC, LGB1PC  
(See Instructions 501-A00 for Installation, Operation and Maintenance)

Section  
Effective  
Replaces

501  
September 2003  
September 2002

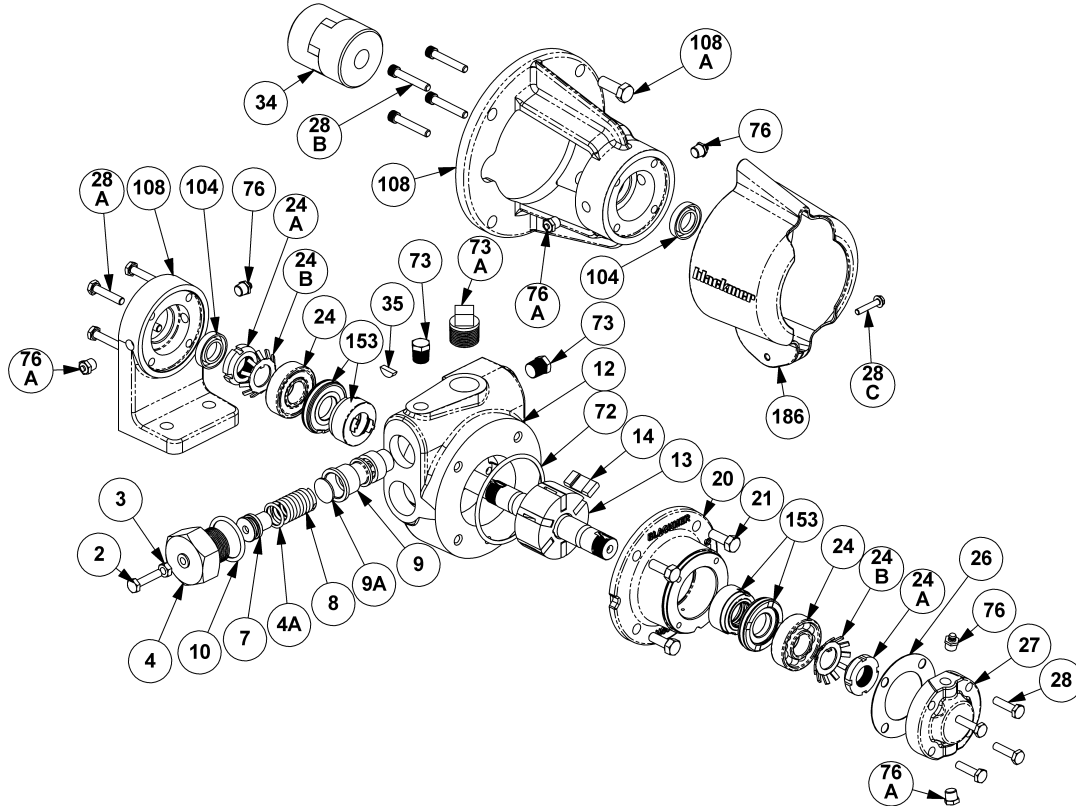

LOCKNUT TOOL

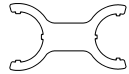

Ref. No.	Description	Parts per Pump	Part No.	Ref. No.	Description	Parts per Pump	Part No.
2	Adjusting Screw – Relief Valve (R/V)	1	432901	28 <sup>†</sup>	Capscrews – Bearing Cover	4	920080
3	Locknut – Adjusting Screw	1	922811	28A <sup>†</sup>	Bracket Mounting Screws	4	920090
4	Cover – R/V	1	412901	28B <sup>†</sup>	Bracket Mounting Screws	4	920101
4A	O-Ring – Spring Guide	1	<sup>1</sup> 711940	28C	Guard Screw	1	920026
7	Spring Guide – R/V	1	422901	34	Coupling Half – Pump	1	906150
8	Spring – R/V	1	472901		Coupling Half – Motor (56C)		906151
9	Valve – R/V	1	452901		Coupling Half – Motor (143-145TC/184C)		906147
9A	Disc – R/V	1	442901		Coupling Spider		906155
10	O-Ring – R/V Cover	1	<sup>1</sup> 701965	35	Key – Shaft	1	<sup>1</sup> 909126
12 <sup>†</sup>	Cylinder – LGF1, LGB1	1	022914	72	O-Ring – Head	1	<sup>1</sup> 711941
	Cylinder – LGF1P, LGB1P		022915	73	Gage Plug (1/4")	2	908198
13	Rotor & Shaft Assembly, Six Vane <sup>2</sup> (Includes Ref. Nos. 24A & 24B)	1	262907	73A <sup>†</sup>	Gage Plug (3/4")	1	908225
14	Vane – Duravane (Std.) <sup>3</sup>	4, 6	<sup>1</sup> 092913	76	Grease Fitting	2	317815
20 <sup>†</sup>	Head	1	032905	76A	Grease Relief Fitting	2	701992
21	Capscrews – Head	4	920178	104	Grease Seal	1	<sup>1</sup> 331934
24	Ball Bearing	2	<sup>1</sup> 903405	108	Bracket - (base mount) - LGB1(P)D	1	832913
24A	Locknut – Bearing	2	903531		Bracket (C-faced footless) - LGF1(P)D		832912
24B	Lockwasher – Bearing	2	<sup>1</sup> 903532	108A	Capscrews – Bracket	4	920331
26 <sup>†</sup>	Gasket – Bearing Cover	1	<sup>1</sup> 383075	108B	Bracket (C-faced footed)		SEE PAGE 2
27 <sup>†</sup>	Bearing Cover	1	043071	186	Guard	1	804120
					Tool - Locknut		903090
					Kit – Maintenance (4-Vane)		898916
					Kit – Maintenance (6-Vane)		898994

<sup>1</sup> Included in Maintenance Kit. <sup>2</sup> Discontinued 'D' and 'C' models shipped with a 4-vane rotor. The current 6-vane rotor is fully interchangeable as long as the slotted vanes (pn 092913) are used. <sup>3</sup> The current slotted vanes (pn 092913) may be used in either the 6-vane or 4-vane rotors. The discontinued solid vanes may be used in the 4-vane rotors ONLY. Always install the vanes with the slot facing the direction of rotation.

<sup>†</sup> To fit the LGB1(P)C, LGF1(P)C use: Ref. No. 12-022902/022911 respectively, Ref. No. 20-032902, Ref. No. 26-382901, Ref. No. 27-042901, Ref. No. 28-920203, Ref. No. 28A & B-920230, Ref. No. 73A-908198, and Ref. No. 108-832901/832905 respectively.  
Keep this parts list with Installation, Operation and Maintenance Instructions.

**MECHANICAL SEAL**

Ref. No.	Part Name	Parts Per Pump	Part No.
153	Mechanical Seal Assembly	2	<sup>1</sup> 332920
153A**	Jacket Assembly – Seal	2	332922
153B**	Stationary Seat (Steel)	2	332901
153D	O-Ring – Stationary Seat (Buna-N)	2	711916
153F**	Seal Face (Carbon)	2	332902
153G	O-ring – Rotating (Buna-N)	2	711939

<sup>1</sup> Included in Maintenance Kit \*\* Ref. Nos. 153A, 153B & 153F are not available

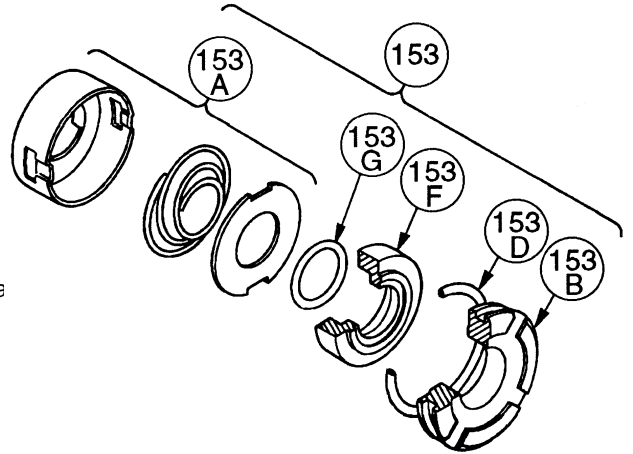

**MOUNTING BRACKET**

Ref. No.	Part Name	Parts Per Pump	Part No.
108B	Bracket (C-faced footed) – LGF1(P)D	1	833000

