

BLACKMER PARTS LIST

PUMP MODELS: LGLD4A, LGL4A

DISCONTINUED MODELS: LGL4, LGLD4

(See Instructions 501-E00 for Installation, Operation and Maintenance)

962007
Page 1 of 2

PARTS LIST
501-E01

Section 501
Effective May 2003
Replaces July 2002

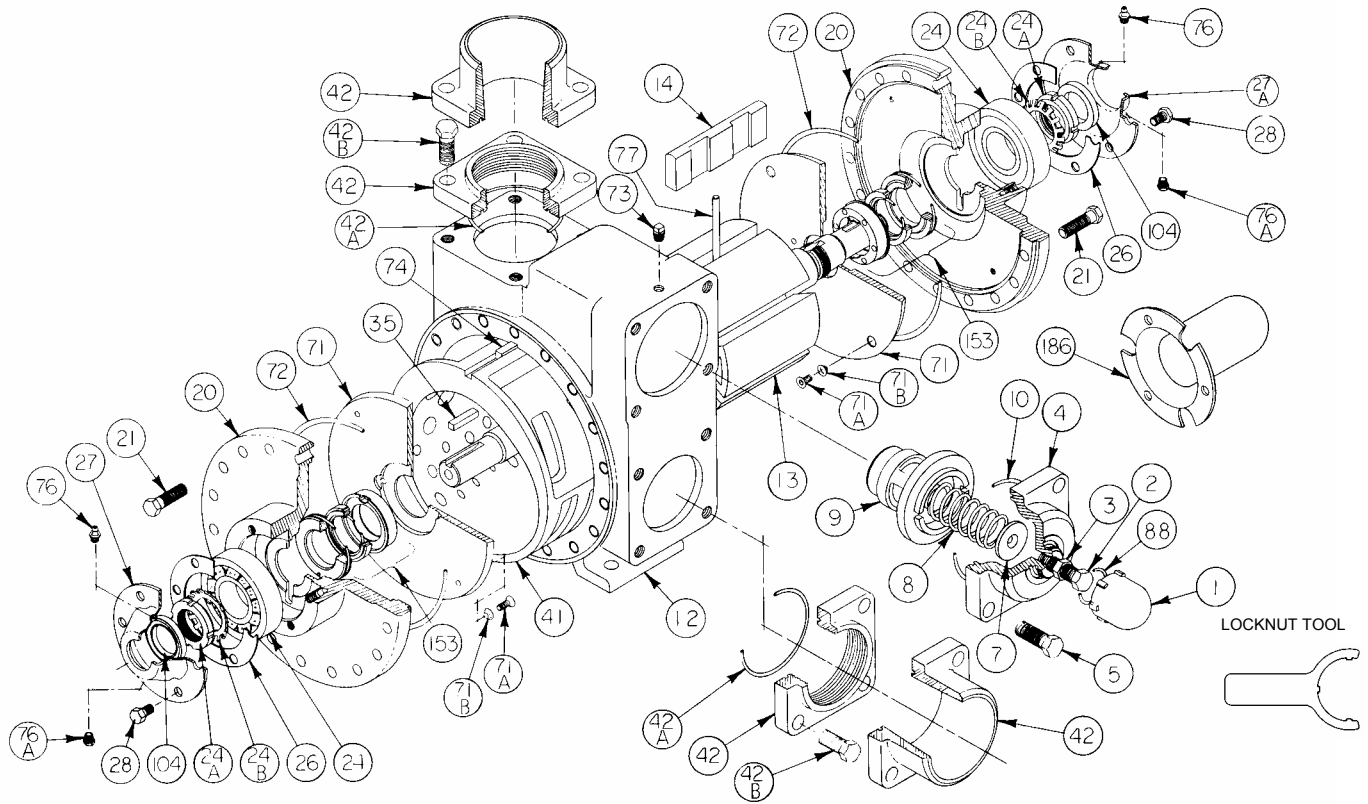

Ref. No.	Description	Parts Per Pump	Part No.	Ref. No.	Description	Parts Per Pump	Part No.
1	Cap - Relief Valve (R/V)	1	413952	28	Capscrews - Bearing Cover	12	920286
2	Adjusting Screw - R/V	1	NOTE 3	35	Key - Shaft	1	¹ 909183
3	Locknut - Adjusting Screw	1	NOTE 3	41	Liner	1	² 182000
4	Cover - R/V	1	412001	42	Flange - 3" NPT	1 - 2	652012
5	Capscrew - R/V Cover	4	920663		Flange - 3" Weld		652007
7	Spring Guide - R/V	1	426355		Flange - 4" Weld		652005
8	Spring - R/V	1	NOTE 3	42A	O-Ring - NPT, Weld Flange	2	¹ 701937
9	Valve - R/V	1	452001	42B	Capscrew - NPT Flange	8	920663
10	O-Ring - R/V Cover	1	¹ 701946		Capscrew - Weld Flange		920640
12	Casing	1	NOTE 3	71	Disc	2	¹ 062039
13	Rotor & Shaft Assy, Dbl. End - LGLD4(A) (Includes Ref. No. 24A & 24B)	1	² 262024	71A	Machine Screw - Disc	8	² 920015
	71B*			Lockwasher - Machine Screw	8	² 909634	
	72			O-Ring - Head	2	¹ 702039	
14	Vane - Duravane (Std.)	6	¹ 092019	73	Gage Plug	2	908198
20	Head	2	032039	74	Key - Liner	1	² 182040
21	Capscrews - Head	36	920532	76	Grease Fitting	2	317815
24	Ball Bearing	2	¹ 903172	76A	Grease Relief Fitting	2	701992
24A	Locknut - Bearing	2	² 903541	77	Push Rod	3	¹ 122005
24B	Lockwasher - Bearing	2	¹ 903542	88	O-Ring - R/V Cap	1	¹ 701926
26	Gasket - Bearing Cover	2	¹ 385125	104	Grease Seal - LGLD4(A)	2	¹ 331908
27	Bearing Cover - LGLD4(A)	2	041815			Grease Seal - LGL4(A)	
	Bearing Cover - Inboard, LGL4(A)	1		186	Shaft Protector (LGLD4 Only)	1	341801
27A	Bearing Cover - Outboard, LGL4(A)	1	041817		Tool - Locknut		903092
					Kit - Maintenance		898922
					Kit - Rebuild		899022

¹ Included in Maintenance Kit and Rebuild Kit ² Included in Rebuild Kit
Keep this parts list with Installation, Operation and Maintenance Instructions.

Note 3 - See Table on other side for proper parts.

MECHANICAL SEAL - STANDARD

Ref. No.	Part Name	Parts Per Pump	Part No.
153	Mechanical Seal Assembly	2	¹ 332050
153A	Stationary Seat (Hardened Steel)	2	**
153B	Seal Face (Carbon)	2	**
153C	Jacket Assembly	2	**
153D	O-Ring - Stationary (Buna-N)	2	701934
153E	O-Ring - Rotating (Buna-N)	2	711912

¹ Included in Maintenance Kit and Rebuild Kit

** NOTE: Mechanical Seal Ref. No. 153 is only sold as a complete assembly.
Ref. Nos. 153A, 153B & 153C are not available as separate replacement parts.

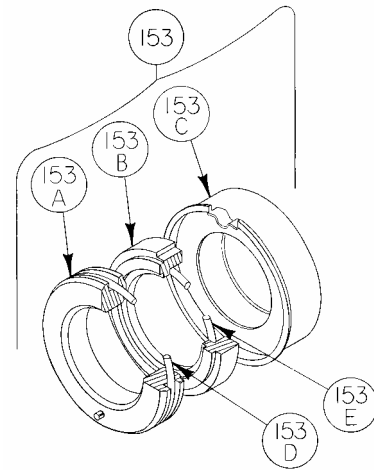

Use the table below to determine the proper parts for each model.

Ref. No	Part Name	Parts Per Pump	LGLD4A and LGL4A	Discontinued LGLD4 and LGL4
			Part No.	Part No.
2	Adjusting Screw - R/V	1	436310	436307
3	Locknut - Adjusting Screw	1	432039	436355
8	Spring - R/V	1	472039	476305
12	Casing	1	012009	012000

Use Dimension 'A' as shown in the drawing to determine the pump model number.
The pump model number will also be shown on the nameplate.

Model	Dim 'A'	
LGLD4A, LGL4A	2.19 in.	5.56 cm.
LGLD4, LGL4	1.75 in.	4.45 cm.

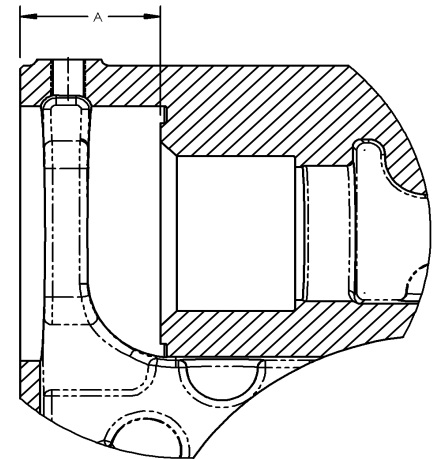
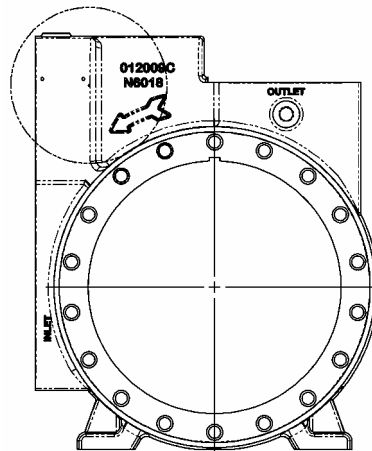

HYDRAULIC MOTOR ADAPTER PARTS

REF. NO.	PART NAME	PARTS PER PUMP	PART NO.
See Below	Hydraulic Motor Adapter Kit *	See Below	892037
26A	Gasket – Hydraulic Motor Adapter	1	381817
28A	Capscrew – Hydraulic Motor Adapter / Head	6	920369
34	Coupling w/ Setscrew	1	906970
35	Key – Coupling	1	909184
76	Grease Fitting	1	317815
76A	Grease Relief Fitting	1	701992
135	Hydraulic Motor Adapter	1	041829
135A	Capscrew – Adapter / Motor	2	920510

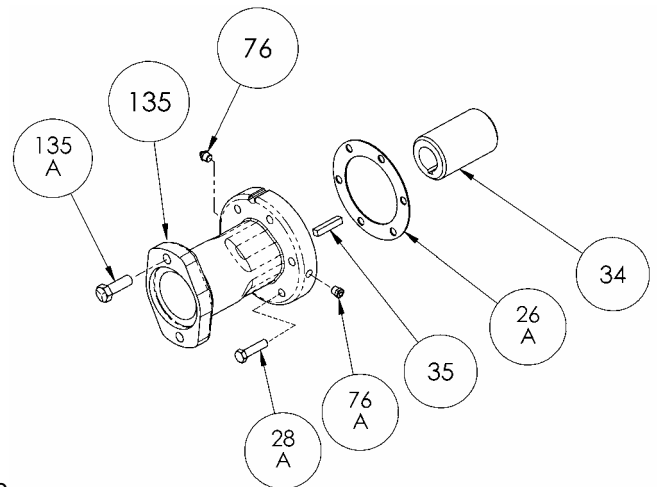

* Hydraulic Motor Adapter Kits shipped prior to Spring 2002 were of a two piece design – refer to page 206-C00.