

# Type P650, P163A and P164A Cable Actuator Instruction Manual



## WARNING

Failure to follow these instructions or to properly install and maintain this equipment could result in an explosion, fire and/or chemical contamination causing property damage and personal injury or death.

Fisher equipment must be installed, operated, and maintained in accordance with federal, state, and local codes and Fisher instructions.

Only personnel trained in the proper procedures, codes, standards, and regulations of the applicable industrial service should install and service this equipment.

## Introduction

### Scope of Manual

This manual covers instructions for Types P650, P163A and P164A cable actuators.

### Description

**Type P650** – Primary cable control for remote operation of all 1-1/4 inch, 2 inch, and 3 inch size Fisher internal valves. Assembly includes two fusible links, a return spring, a 20 foot cable, two cable clamps, a connector, and a machine screw.

**Type P163A and P164A** – Auxiliary remote release assemblies that permit closing the internal valve from a point other than at the primary cable control (P650). Identical except for cable length, the Type P163A is 25 feet and the Type P164A is 50 feet. Both can be installed through mounting brackets up to 3/8 inch thick. Also included are casing and inner cable clamps.

## Operation

There are three notches on the Type P650 control to give a travel of 4, 5, or 6 inches. All 1-1/4 inch size Fisher internal valves require the Type P650 be set in the first notch (4 inch travel), and all 2 and 3 inch size valves require the Type P650 be set in the third notch (6 inch travel) to assure adequate valve operating lever travel. To open the internal valve, pull the Type P650 handle to the correct notch. To close the valve, hold the handle and push in on the release knob.

In emergencies, the release knob on the Type P650 can be pushed to close the valve, but this procedure is not recommended for everyday usage. The internal valve can be closed from the auxiliary remote release points by pulling the Type P163A or P164A tee handle. After the auxiliary release has been operated and the internal valve has closed, push the Type P163A or P164A tee handle to its original position to reset the latching mechanism of the Type P650.

Fusible elements at the internal valve, primary cable control, and auxiliary remote release provide thermal release.

## Installation

Refer to the installation drawing.

**Step 1:** Mount the Type P650 primary control at the desired location using four metal screws (not furnished) in the 7/16 inch diameter holes. Allow 8-1/2 inch additional space to permit full extension of the operating handle.

**Step 2:** Connect the cable and the fusible link to the Type P650 primary control as shown, and run the cable through conduit and/or pulleys to the operating lever on the internal valve.

### Note

**Minimum conduit bend radius of 6 inches and minimum pulley diameter of 4 inches.**



# Type P650, P163A and P164A

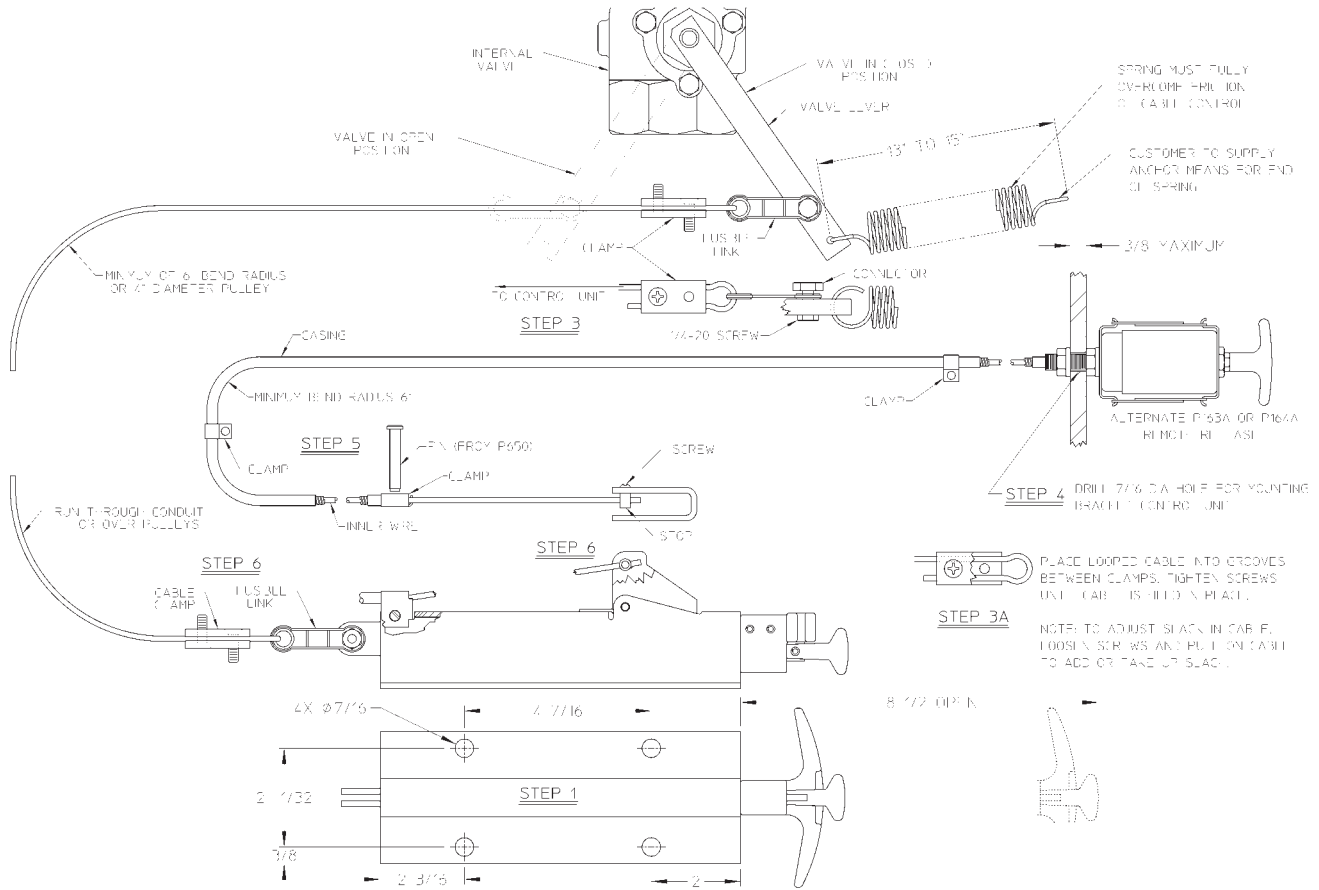

Installation Drawing

**Step 3:** Connect the fusible link and the cable to the internal valve's operating lever as shown. The cable slack must be adjusted as shown in Step 3A of the drawing in order to get the proper operating lever travel on the internal valve. The internal valve lever swings through a 70° arc (90° on the 1-1/4 inch size valves) from the closed to the open position.



## CAUTION

**Make sure the Type P650 moves the operating lever to within 5° of the fully open position. Failure to adjust the opening correctly can cause premature excess flow closure during operation.**

Check to see if the internal valve is open the required amount by manually moving the operating lever with the Type P650 latched in the required notch (see "Operation"). If the valve operating lever can be rotated further than 5° toward the open position, the cable must be tightened. The internal valve will close prematurely if sufficient operating lever travel is not obtained, but in all cases leave a small amount of travel from the full open position. The cable should be taut with the internal valve operating lever in the open position and the Type P650 latch in the required notch. There should be slack in the cable when the operating lever is in the closed position. Attach the return spring to the operating lever as shown. The return spring must overcome the cable drag and close the internal valve when the control is released.

**Step 4:** To mount the Type P163A or P164A release, first select a location that meets DOT, NFPA Pamphlet 58, and/or state regulations. A 7/16 inch diameter hole is required to mount the assembly.

**Step 5:** Run the release cable to the Type P650 latch, making sure to secure the cable with clamps and keep a minimum bend radius of 6 inches in the cable.

**Step 6:** Pull the release handle (Type P163A or P164A) out about one foot so that inner cable will not be cut too short.

**Step 7:** Attach the casing clamp to the Type P650 rear pin as shown. Cut the Type P163A or P164A cable and housing to the proper length to reach through the casing clamp.

**Step 8:** Pull the inner wire back through the casing (push in the release handle). Remove about 1 inch of vinyl casing cover from the end of the housing. Thread the cable through the casing clamp and fit the housing into the clamp.

**Step 9:** Assemble the inner cable clamp and screw through the Type P650 latch as shown. Thread the inner cable through the clamp and tighten the screw.

Leave only enough slack in the cable to allow the Type P650 latch to engage the slide.

Check the following after completing the assembly:

1. The internal valve operating lever should be in the open position when the Type P650 handle is in the required notch.
2. The release assemblies (Type P163A or 164A) must be capable of deactivating the P650 primary control, closing the internal valve.
3. The internal valve must be completely closed with the primary control (Type P650) in the closed position.

## Maintenance



## CAUTION

**Do not use internal valves and cable controls if they leak, fail to work properly or have been damaged or have missing parts. Prompt repairs should be made by a properly trained serviceman. Continued use without repair can create a hazardous or injurious situation.**

A simple preventative maintenance program for the valve and its controls will eliminate a lot of potential problems.

**Fisher recommends these steps be conducted once a month:**

1. Inspect the operating lever and cable controls to see that they operate freely and that there is no leakage around the retainer nut. If there is sticking or leakage, replace the packing and bushings. Refer to internal valve instruction manual.
2. Check for tight closure of the internal valve seat discs regularly. Any leakage indicates a defect in the seat caused by wear or from dirt or scale lodging and embedding in the discs. To check for leakage, close the valve and exhaust downstream pressure. Close the first valve downstream from the internal valve, and note any pressure buildup between the closed valve and the internal valve by means of a pressure gauge. If leakage is indicated, both discs should be replaced. If piping is cold allow it to warm to ambient temperature.
3. All operating controls should be inspected, cleaned and oiled. Rust, corrosion, and dirt can make the controls inoperable. The controls should be checked to see that they fully open—but not over-travel—the internal valve operating lever and operator freely to close the valve.

# Type P650, P163A and P164A

---

*The contents of this publication are presented for informational purposes only, and while every effort has been made to ensure their accuracy, they are not to be construed as warranties or guarantees, expressed or implied, regarding the products or services described herein or their use or applicability. We reserve the right to modify or improve the designs or specifications of such products at any time without notice.*

## **Emerson Process Management**

### **Fisher Controls International, LLC**

P.O. Box 8004

McKinney, Texas 75070, USA

Telephone: 1 (800) 432-8711

Telephone: 1 (972) 542-5512

[www.FISHERregulators.com/lp](http://www.FISHERregulators.com/lp)



©Fisher Controls International LLC, 2002; All Rights Reserved

Fisher and Fisher Regulators are marks owned by Fisher Controls International LLC. The Emerson logo is a trade mark and service mark of Emerson Electric Co. All other marks are the property of their respective owners.