

October 2007

Type P539 Pneumatic Actuator



WARNING

Failure to follow these instructions or to properly install and maintain this equipment could result in an explosion and/or fire causing property damage and personal injury or death.

Fisher® equipment must be installed, operated, and maintained in accordance with federal, state, and local codes and Fisher instructions. The installation in most states must also comply with NFPA No. 58, ANSI K61.1 and DOT standards.

Only personnel trained in the proper procedures, codes, standards, and regulations, of the LP-gas or anhydrous ammonia (NH₃) industries should install and service this equipment.

Introduction

Scope of Manual

This instruction manual covers installation of the Type P539 Pneumatic Actuator onto the N550 Series Emergency Shutoff Valve (ESV).

Description

Type P539 pneumatic actuator permits opening and closing Fisher N550 Series Snappy Joe® emergency shutoff valves (ESVs) both at the valve with the use of a pneumatic 3-way valve and from a remote location. The actuator opens the valve when pressure is applied.

Upon loss of pressure, the N550 Series closes, assisted by the spring in the pneumatic actuator.

Specifications

The Specifications section lists specifications for the Type P539 Pneumatic Actuator.



P1136

Figure 1. Type P539 Installed on N550 Series

Installation



CAUTION

Minimum air consumption and maximum ESV life are obtained by using a minimum actuator operating pressure between 20 to 40 psig (1,38 to 2,76 bar). A Fisher 67C Series regulator can be used to supply pressure to the actuator if desired.

Do not use LP-Gas as a pressure source for the Type P539 Actuator. Use only Air or Nitrogen.



WARNING

When installing the bracket on N550 Series already in-line, first remove all line pressure, inlet and outlet, from the N550 Series Valve. Failure to do so could result in personal injury.

Note

The external spring is not required after installation of the Type P539 pneumatic actuator.



Type P539

Specifications

| | |
|---|---|
| Pressure Source Air or Nitrogen | Temperature Limits -40° to 150°F (-40° to 66°C) |
| System Pressure Limits Minimum: 20 psig (1,38 bar) Maximum: 40 psig (2,76 bar) Recommended: 20 to 25 psig (1,38 to 1,72 bar) | Return Mechanism Internal spring, no air |
| | Melt Point 212°F (100°C) |

Refer to Figure 2, **for units with an external spring:** Remove the bolt (key 23), spring mandrel (key 61), the external spring (key 62), fuse link (key 22), operating lever (key 18), latch block (key 36), and the rear gland bolt (key 33). **KEEP THE BOLTS (keys 23 and 33) AND THE RETAINER (key 24).**

Refer to Figure 2, **for units without an external spring:** Remove the latch block (key 36), fuse link (key 22), bolt (key 23), operating lever (key 18), and the rear gland bolt (key 33). **KEEP THE BOLTS (keys 23 and 33) AND THE RETAINER (key 24).**

Refer to Figure 3, **mounting the actuator as following steps:**

1. Mounting the actuator BRACKET the same direction as Figure 3 onto the valve's rear gland. Turn the rear gland plate half rotation clockwise to apply tension to the internal spring. Tighten the two rear gland bolt (key 33). **DO NOT OVER TIGHTEN THE GLAND BOLT** because binding of the ESV shaft could occur. Tighten the gland bolt only enough to prevent leakage.
2. Install the bracket spacer (key 16) and hex bolt (key 15) through hole in the bracket and attach to the N550 Series body.

Note

The clevis (key 8B) is factory installed at 0.79-inch (20,1 mm) from the face of the brake chamber for optimal installation on N550 Series. The lever is also factory installed with the wide edge by the slot being away from the brake chamber to take the actuator force.

3. Put the LEVER SPACER (key 17) on the ESV shaft and then the LEVER, reinstall the BOLT (key 23) and the WASHER (key 7).
4. Connect the actuating pressure line tubing to the AIR PORT. Quick Connect fitting.

If the actuator does not close, adjust the clevis' position by loosening the CLEVIS NUT (key 8E) and adjust the CLEVIS' (key 8B) position to fit the LEVER (key 5) on the ESV shaft, then tighten the CLEVIS NUT to hold the CLEVIS at this position.

After installing the unit, operate the actuator with pressure to see that it smoothly opens and closes the N550 Series without sticking or jamming. Check to make sure the N550 Series shuts tightly.

A small 3-way control valve (sold separately, part number T1139599012) for pneumatic ESV installations can be used as primary control (used to open or close the ESV) or an auxiliary remote release (close only).

Placing the valve's button in the upward position permits pressure to the actuator; pushing the button down exhausts pressure to close all valves connected to the system.

Maintenance



WARNING

Only qualified service person should attempt to repair these valves. Before starting any type of repair, close off the upstream valve and remove all pressure from both the inlet and outlet of the N550 Series Emergency Shutoff Valve.

Because the actuator has a diaphragm seal and no rod bearing, internal lubrication is not required. Periodic lubrication of the operating lever/clevis pivot is recommended.

At least once a month inspect and check the following things:

1. See that the actuator fully opens and closes the ESV without sticking. Keep actuator's rod free of any build-up of mud, corrosive or other foreign materials. Such a build-up could prevent the actuator from closing which could jam the internal valve in the open position. Do not permit this condition to occur.

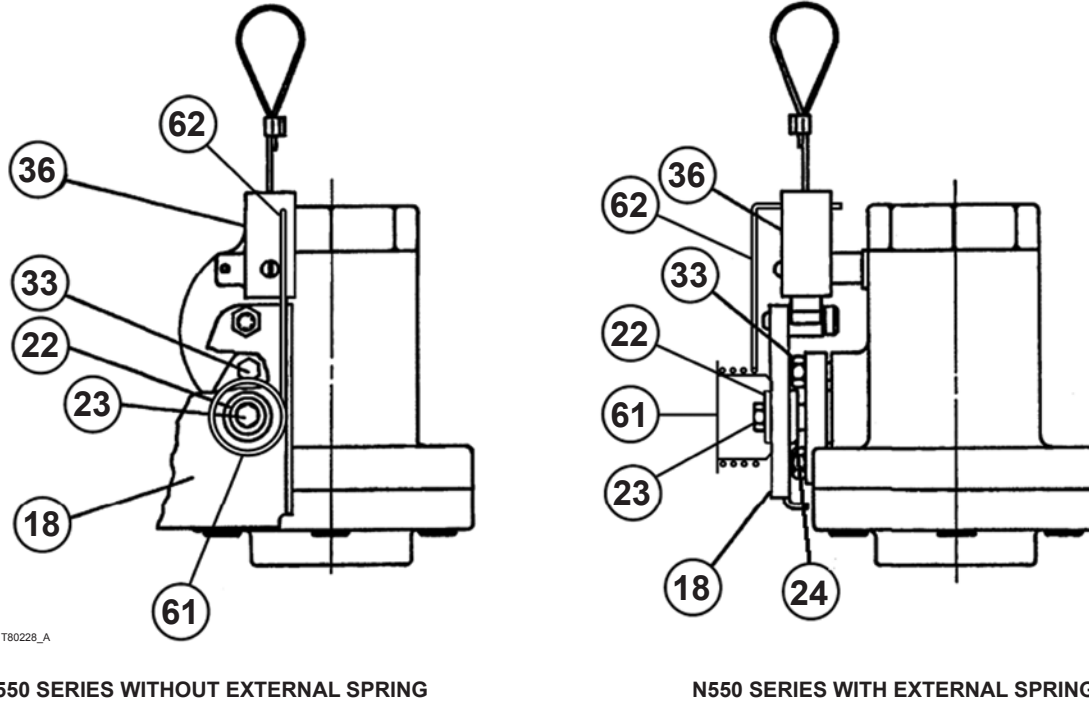

Figure 2. N550 Series Valve Prior to Mounting Type P539

2. Make sure that the lever, latch, and release are working smoothly. The latch parts and lever are easily accessible for replacement or repair by removing the securing bolts (key 23).
3. Check for packing and joint leakage on the N550 Series valve.

Parts Ordering

CAUTION

These actuators are produced with common automotive service chambers, customized specifically for use with Fisher® valves. **DO NOT use a standard, off-the-shelf service chamber for replacement as valve damage can occur. The service chamber push rod has been modified to work specifically with Fisher valves. Fisher recommends contacting your local distributor for replacement service chambers.**

When corresponding about this equipment, always reference the equipment type number found on the nameplate. A Replacement Parts List, MCK-1155, D450042T012 is available for the N550 Series Valves.

When ordering replacement parts, reference the complete 11-character part number of each part. For actuator repair kit, order part number GE29511X012.

Should the user desire to repair the service chamber diaphragm and outer clamp, it is recommended to contact the local Haldex office for a listing of replacement parts and procedures for repairing your service chambers. Reference the SC09 brake chamber for the Type P539 model.

Parts List

| Key | Description | Part Number |
|-----|------------------------|-------------|
| 1 | Mounting Bracket | GE29440X012 |
| 5 | Lever | GE29509X012 |
| 6 | Pin, Cotter | ----- |
| 7 | Flat Washer | V120006X012 |
| 8 | Brake Chamber Assembly | GE31134X012 |
| 8A | Brake Chamber | GE29511X012 |
| 8B | Clevis | GE33509X012 |
| 8C | Clevis Pin | GE33511X012 |
| 8D | Cotter Pin | GE33526X012 |
| 8E | Jam Nut | ----- |
| 9 | Fuse Plug | T1033699982 |
| 10 | Push-in Fitting | GE33586X012 |
| 12 | Spring Lock Washer | 1C225728982 |
| 15 | Hex Socket Cap Screw | 1C8559X0022 |
| 16 | Spacer | GE33481X012 |
| 17 | Spacer | GE33552X012 |
| 18 | Label (Not shown) | GE33673X012 |

Type P539

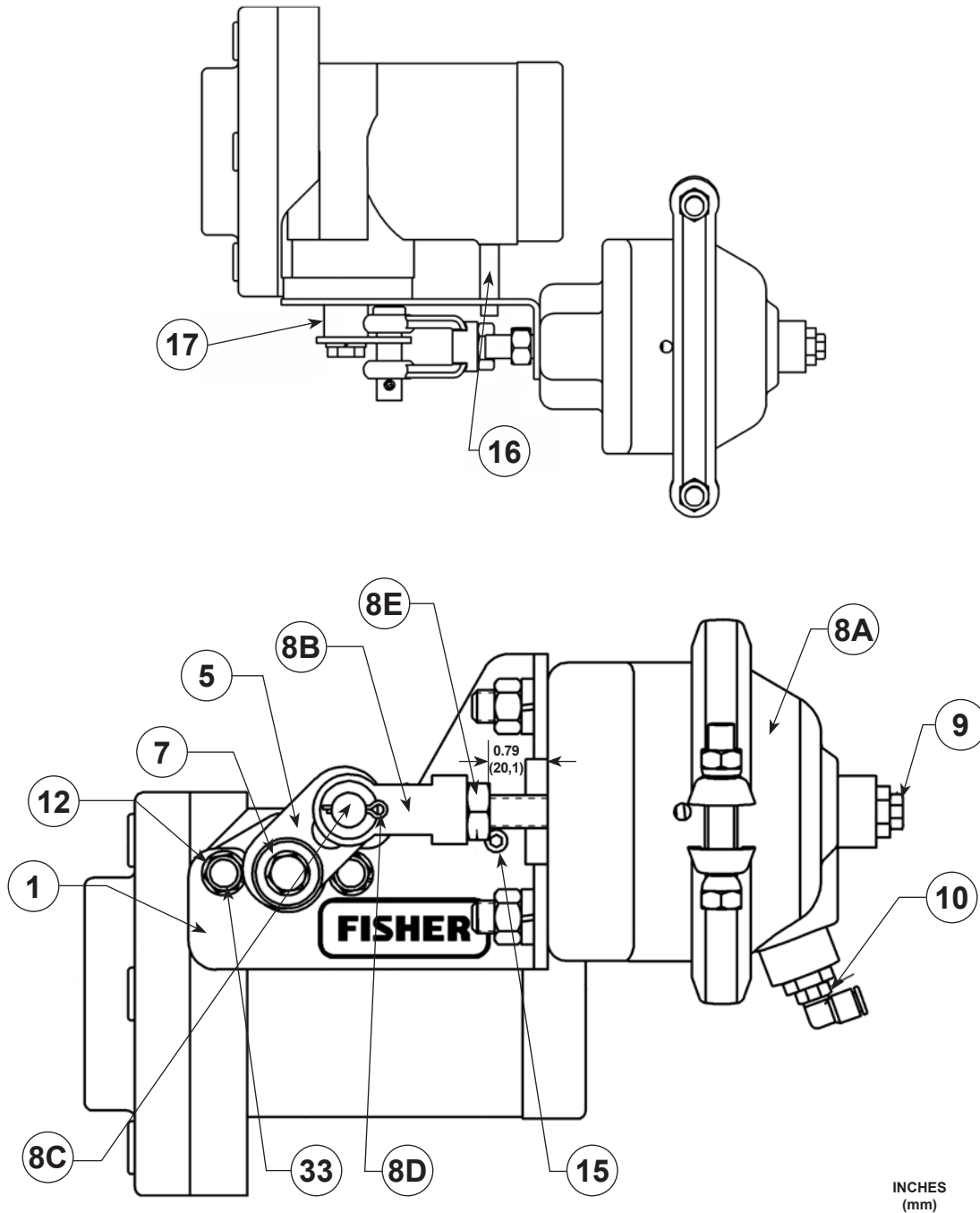

Figure 3. Type P539 Pneumatic Actuator

Fisher and Fisher Regulators are marks owned by Fisher Controls International, LLC. The Emerson logo is a trademark and service mark of Emerson Electric Co. All other marks are the property of their respective owners.

The contents of this publication are presented for informational purposes only, and while every effort has been made to ensure their accuracy, they are not to be construed as warranties or guarantees, expressed or implied, regarding the products or services described herein or their use or applicability. We reserve the right to modify or improve the designs or specifications of such products at any time without notice.

Fisher does not assume responsibility for the selection, use or maintenance of any product. Responsibility for proper selection, use and maintenance of any Fisher product remains solely with the purchaser.

Emerson Process Management

Fisher Controls International, LLC.
P.O. Box 8004
McKinney, Texas 75070, USA
Telephone: 1 (800) 558-5853
Telephone: 1 (972) 548-3574